

**Engine Room Simulator**  
**ERS Sulzer 12RTA 84(C)**

**Machinery & Operation**

**Part 3**

**Machinery & Operation**



## TABLE OF CONTENTS

Section	Page
<b>1 SEQUENCE DIAGRAMS</b> .....	<b>2</b>
1.1 First Start to Own Supply .....	2
1.2 Own Supply to Harbour Condition.....	3
1.3 Harbour Condition to Ready for Departure .....	4
1.4 Manoeuvre Mode to Sea Passage Mode .....	5
<b>2 ELECTRICAL PLANT</b> .....	<b>7</b>
2.1 Diesel Generators .....	7
2.2 Electrical Power Plant .....	11
2.3 Main Switchboard .....	15
2.4 Main Switchboard – Synchronising .....	17
2.5 Power Chief – Generator Control .....	19
2.6 Electrical Consumers .....	23
2.7 Reefer Container.....	25
2.8 Battery Charging System .....	27
2.9 Emergency Switchboard.....	28
<b>3 MAIN ENGINE AND MAIN ENGINE SYSTEMS</b> .....	<b>29</b>
3.1 Main Engine .....	29
3.2 ME Lubrication Oil System.....	31
3.3 ME Bearings.....	35
3.4 ME Piston Ring Monitor .....	39
3.5 Fresh Water System.....	41
3.6 Fuel Oil System .....	45
3.7 ME Turbocharger System .....	51
3.8 ME Cylinder.....	57
3.9 ME Local Control.....	59
3.10 Cylinder indications .....	61
<b>4 PROPELLER AND STEERING GEAR SYSTEMS</b> .....	<b>67</b>
4.1 Propeller Servo Oil System .....	67
4.2 Stern Tube System .....	69
4.3 Steering Gear System .....	71
<b>5 SERVICE SYSTEMS</b> .....	<b>75</b>
5.1 Main Sea Water System.....	75
5.2 Air Ventilation System .....	79
5.3 Air Conditioning Plant .....	81
5.4 Sewage Treatment .....	83
5.5 Incinerator.....	87
5.6 Cathodic Protection System ICCP .....	89
5.7 Starting Air Compressors .....	93



---

5.8	Fuel Oil Bunker System.....	97
5.9	Fuel Oil Service Tanks .....	101
5.10	Fuel Oil Settling Tanks .....	105
5.11	HFO Purifier System .....	107
5.12	Diesel Oil Purifier System .....	115
5.13	Lubrication Oil Purifier System .....	119
5.14	Fresh Water Generator .....	123
5.15	Bilge System and Bilge Separator.....	125
5.16	Refrigeration System.....	133
5.17	Steam Generation Plant .....	137
5.18	Sea Water Ballast System .....	143
5.19	Ship Load .....	147
5.20	AutoChief – Main Engine Control .....	149
5.21	Ship Propulsion.....	155
5.22	Bridge – Main Engine Control.....	156
5.23	Bridge – Ship Course Control.....	157
<b>6</b>	<b>SIMULATOR AND SHIP MODEL PARTICULARS.....</b>	<b>158</b>
6.1	Auto Pulsar System .....	158



**The Process diagrams presented on the monitors have the following colour codes for pipelines:**

- Blue: Fresh water (low and high temperature)
- Green: Sea water
- Yellow: Diesel oil
- Brown: Fuel oil
- Light brown: Lubrication oil
- Grey: Start and service air
- Light blue: Steam

The Process Diagrams are abbreviated T, G, P, etc., meaning:

- T: Temperature
- G: Flow
- P: Pressure
- N: Rpm
- Q: Power
- I: Ampere
- U: Voltage
- F: Frequency
- E: Electrical power
- V: Valve
- L: Level
- X: Miscellaneous variable
- Z: Water or other undesirable contamination index variable
- W: Viscosity

# 1 SEQUENCE DIAGRAMS

## 1.1 First Start to Own Supply

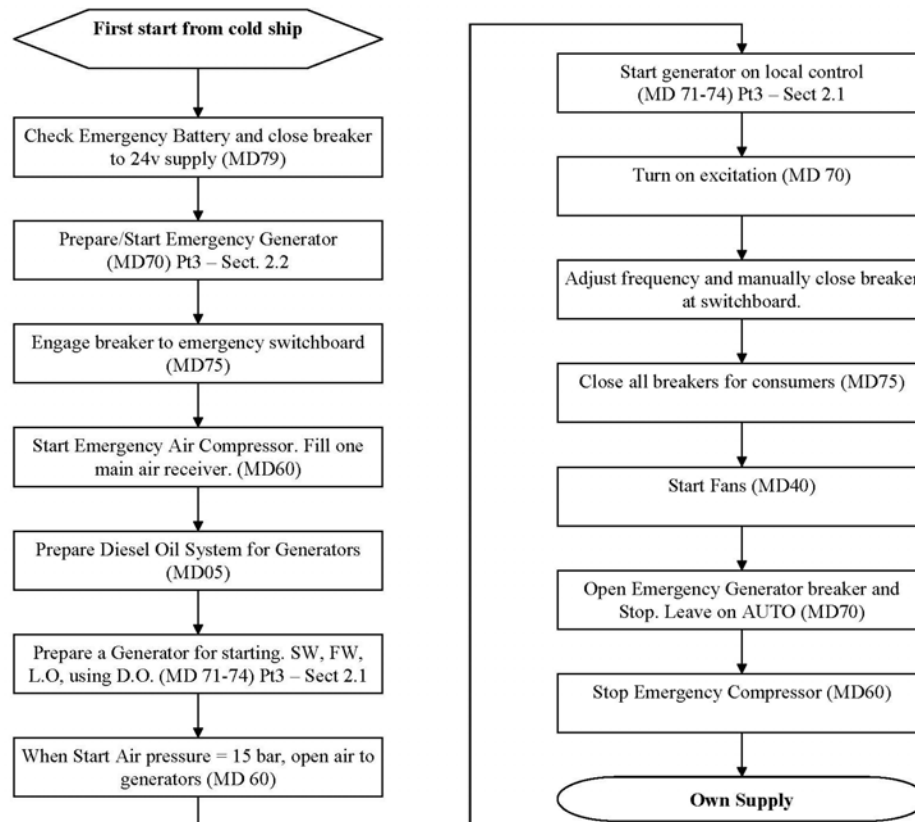

## 1.2 Own Supply to Harbour Condition

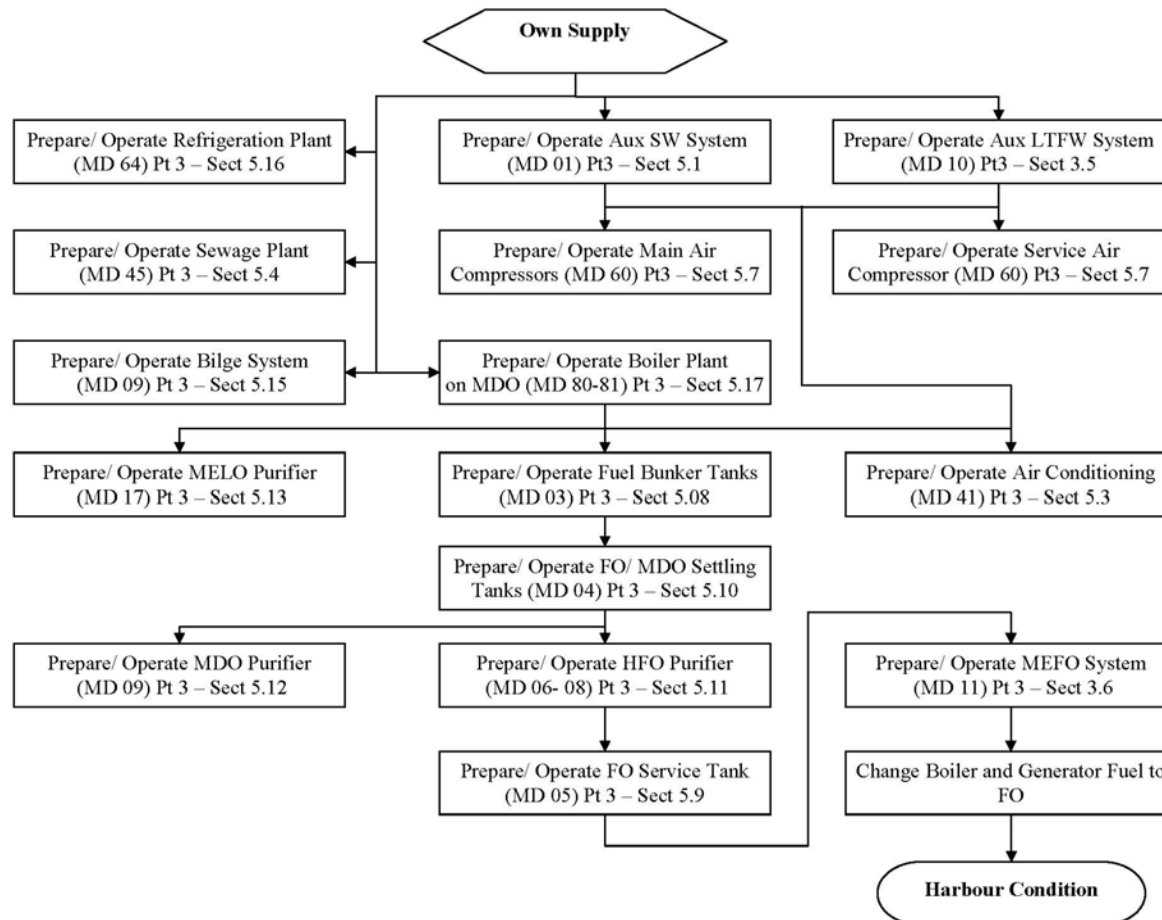

### 1.3 Harbour Condition to Ready for Departure

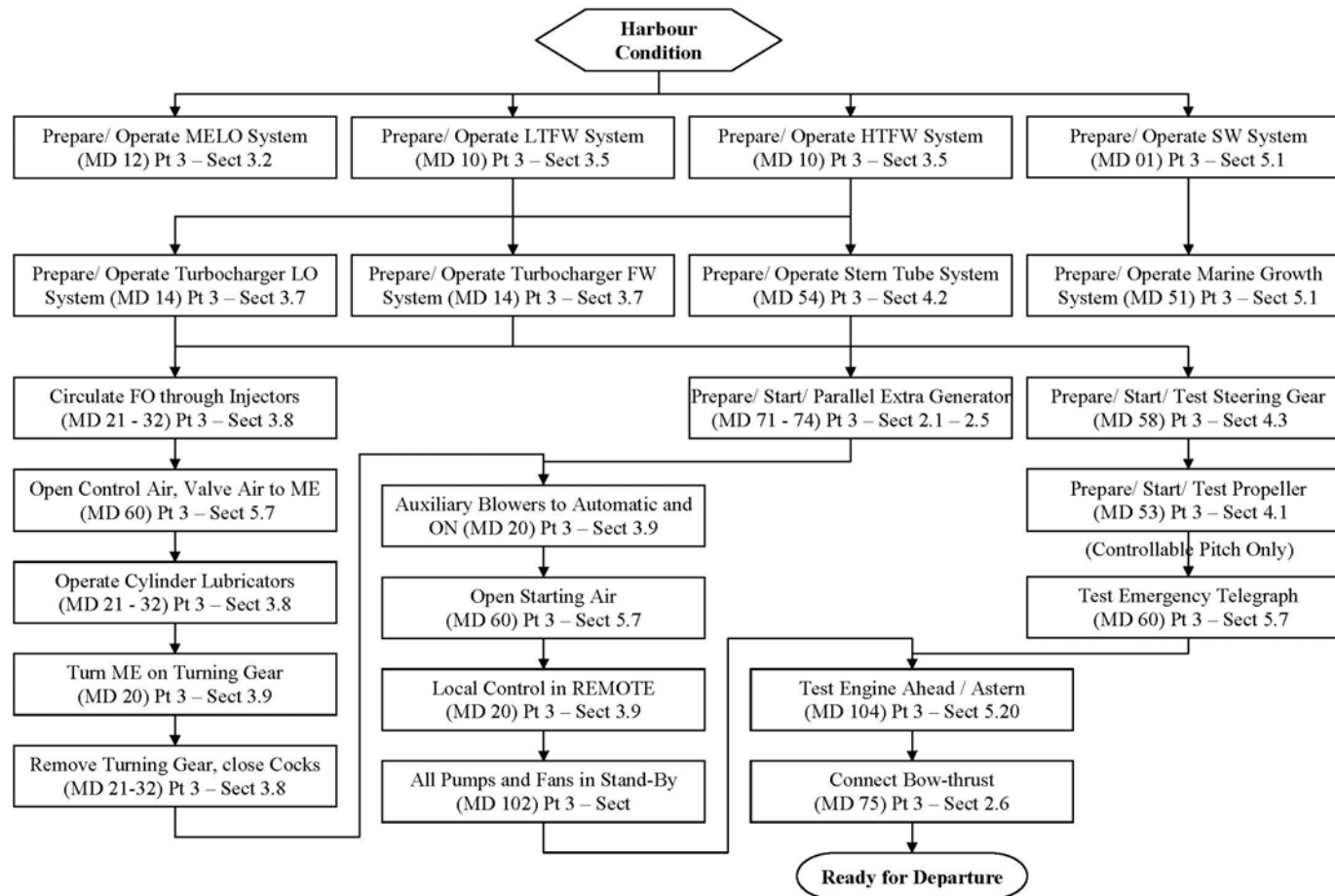



## 1.4 Manoeuvre Mode to Sea Passage Mode

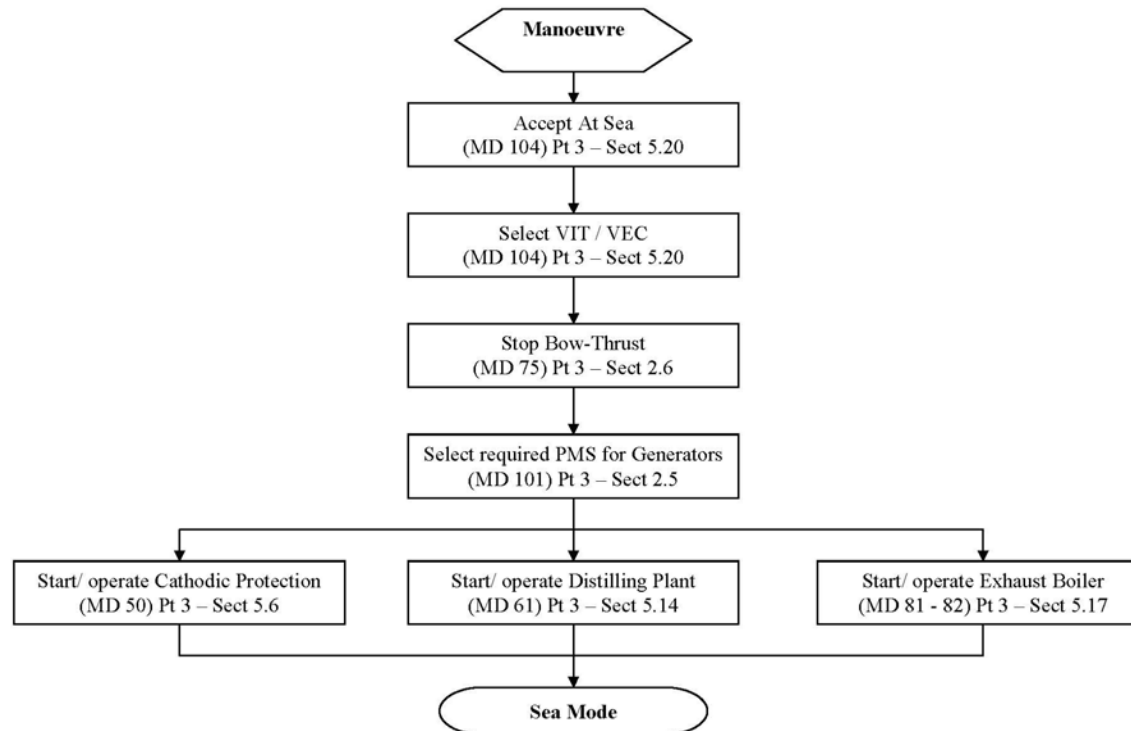

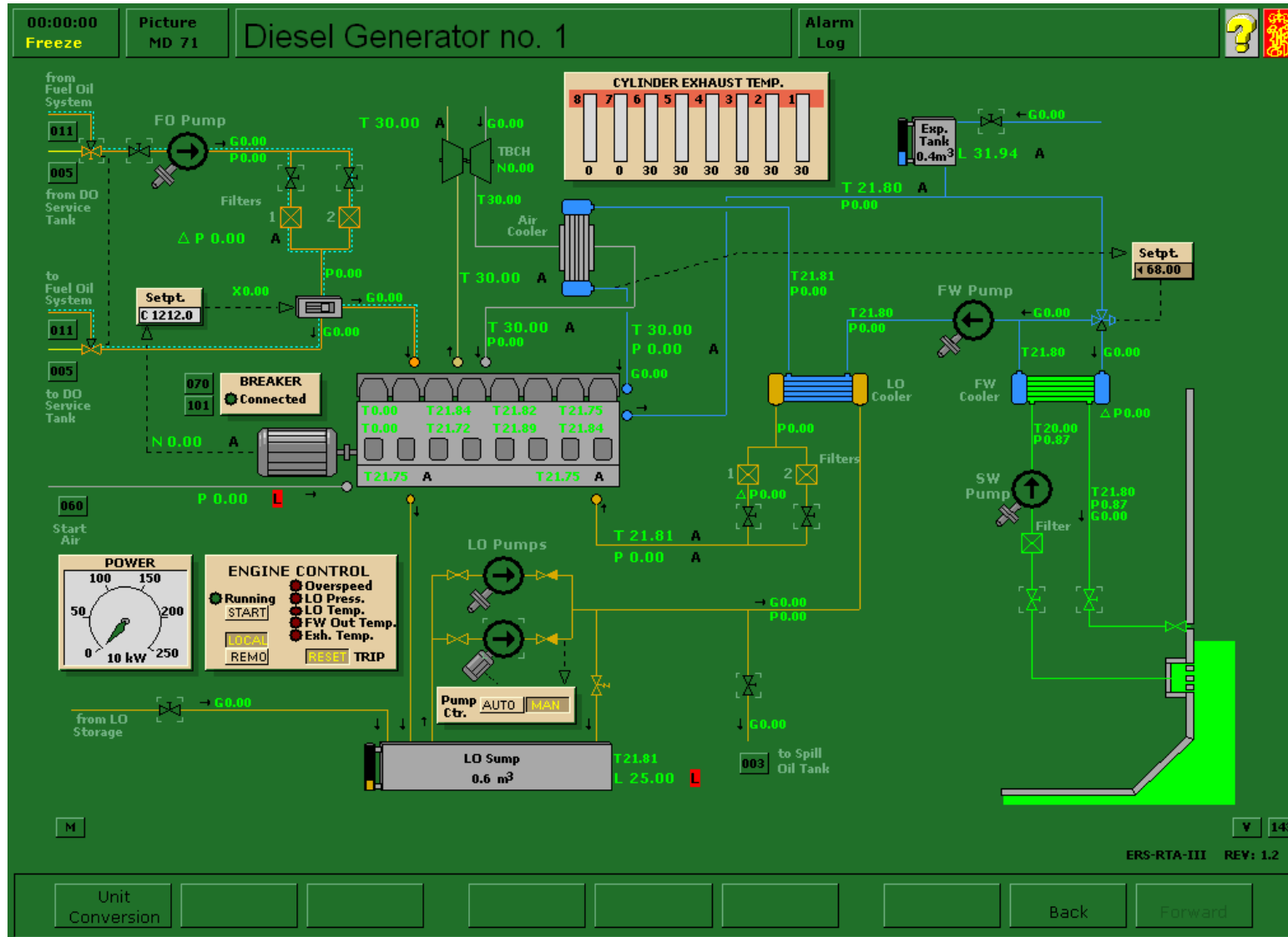



## 2 ELECTRICAL PLANT

### 2.1 Diesel Generators

#### General

The ship is equipped with two 2000kW/2200kVA/440V/60Hz/720 and 2750kW/3000kVA/440V/60Hz/720 rpm synchronous main generators. Each generator is driven by a turbocharged, four-stroke, 6-cylinder auxiliary diesel engine (DG1, DG2, DG3 and DG4).

The auxiliary diesel engines are equipped with separate, integrated systems for cooling water and lubrication oil.

The diesel engines are designed for both diesel and heavy fuel oil operation (700 cst).

#### Description

The engine is equipped with a shaft driven fuel oil pump. The pump takes suction either from the fuel oil supply system or directly from the diesel oil service tank. Shifting between diesel oil and fuel oil is carried out by means of the double 3-way valve, shifting both supply and return direction. The fuel oil pump discharges to the high-pressure pump header through a duplex filter. Surplus oil is returned to the diesel oil service tank or the fuel oil service tank depending on the position of the double 3-way valve.

The lubrication system is equipped with an electrical oil pump and a shaft driven main lubrication oil pump. The electrical pump serves as a pre-lubrication oil pump and as a stand by oil pump in

case of break down of the shaft driven main pump. The pumps take suction from the diesel engine lubricating oil sump and discharge through a freshwater cooled oil cooler and a duplex filter. The oil sump can be refilled from the lubricating oil storage and the oil charge can be drained to the sludge tank by using the electrical oil pump.

The electrical oil pump can be operated in manual or in automatic mode.

Seawater for fresh water temperature cooling is provided by the vessel's main sea water system.

A shaft driven fresh water circulating pump circulates fresh cooling water through the lubricating oil cooler, the scavenging air cooler/heater, cylinder jackets, and the fresh water cooler. The temperature is controlled by a simple proportional controller, controlling the temperature at inlet cylinder jackets.



The governor (rpm controller) settings are available in a pop-up window with the following variables:

- Speed-droop (speed controller droop setting): Default setting = 60%, which represents a speed droop approx. 3%, or 1.8Hz. 100 % = approx. 5% speed droop.
- Speed set point (basic speed at unloaded engine): Default setting = 720 rpm.
- Load limit (speed controller max. Output limit): Default setting for the “maximum fuel lever position” = 100%.
- Compensation lever (speed controller gain): Default setting for the proportional gain is set to 65.
- Compensation valve (speed controller integral time): Default setting = 20 seconds.
- The governor response at different settings can be studied by means of the pop-up TREND window.

**NOTE!** Frequency regulation stops when the Engine is overloaded (when alarm is activated).

The FW temperature controller is a proportional gain controller with BIAS setting. BIAS default setting is 50%, which means that 50% is added.  $(\text{Deviation} * \text{P-Gain}) + \text{BIAS} = \text{Output}$ .

The pre-lubrication pump: Interval lubrication with default setting: 60 seconds on and 600 seconds off. The pre-lubrication pump will stop when the diesel starts, if lubrication oil pump control is set to AUTO, and start when the diesel engine stops.

The Engine Control Panel has the following functions and indications:

- Selection of local/remote control of engine
- Start/stop of engine
- Trip indications
- Reset of trip

**Safety System**

The diesel engines are equipped with a separate, independent safety system acting as a back-up system to the safety system of the Power Chief. The system monitors the engine condition by binary sensors and includes the following adjustable parameters:

<b>Parameter</b>	<b>Normal setting</b>
Over speed	112%
Low Lub Oil Pressure	1,0 bar
High Lub Oil Temp.	85°C
High fresh water Temp.	96°C
High Exhaust Temp.	700°C

If one of the parameters is exceeded, the diesel engine will shut down and a trip alarm is given. A lamp at the local panel indicates the trip condition. To restart the engine, the cause must be found and corrected and the safety system must be reset by pushing the RESET button.

The trip limits can be inspected and changed from the variable page 7115, 7215, 7315 and 7415.



## Operation procedure

In normal operation the generator is in stand by mode with AUTO and priority selected on the POWER CHIEF. While in AUTO mode the generator must be prepared ready to start.

### 1. Preparation

- 1.1 Check level in the fresh cooling water expansion tank and refill if necessary.
- 1.2 Check that the fresh water temperature controller is working and in AUTO – normal set point is 65-75°C.
- 1.3 Ensure that sea water valve to engine driven pump is open.
- 1.4 Check level in lubricating oil sump tank, (min 40%) - refill from storage tank if necessary.
- 1.5 Line up lubrication oil system. Normally one filter is in operation and one filter is cleaned and on stand-by.
- 1.6 Ensure that lubrication oil valve to the sludge tank is closed.
- 1.7 Start the electrically driven lubricating oil pump (pre-lubrication oil pump), and check that the oil pressure is increasing.
- 1.8 Set the electrical lubricating oil pump in AUTO mode by pressing the AUTO button on the PUMP. CTR. panel.
- 1.9 Check water level in the fuel oil service tanks and drain if necessary.
- 1.10 Ensure that fuel oil supply valve from diesel oil service tank and fuel oil system to generator engine is open.
- 1.11 Open fuel oil inlet valve to fuel oil pump.
- 1.12 Open fuel oil valve before fuel oil filters. Normally one filter is in operation and one filter is cleaned and on stand-by.
- 1.13 Check the position of the fuel oil supply 3-way valves.

- 1.14 Open start air valves. Start air must be at least 15 bar (218 psi) on the starting air line.
- 1.15 If any of the alarm lamps (red) at the local panel are lit, press the RESET button.
- 1.16 Start the engine from the local panel by pressing the START button.

### 2. Starting

- 2.1 When the Engine Control panel is in Remote the engine can only be started from the POWER CHIEF panel or Electric Power Plant.
- 2.2 To start locally select local on the Engine Control Panel.
- 2.3 Start the Lubricating oil priming pump manually.
- 2.4 Press Start.
- 2.5 When engine is running, stop Lubricating oil priming pump and set to AUTO.
- 2.6 The generator can now be connected to the main bus using the Electric Power Plant panel.
- 2.7 To use the POWER CHIEF the generator must be switched to Remote.

### 3. Stopping

- 3.1 The generator can be stopped when in AUTO from the POWER CHIEF panel or the Electric Power Plant panel.
- 3.2 To stop locally, firstly ensure that generator breaker is open.
- 3.3 With the Engine Control in Local, press STOP.
- 3.4 If the generator is to be stopped for maintenance, leave control in Local and close starting air valve.
- 3.5 Setting the electric lubricating oil pump in manual prevents start from remote positions.

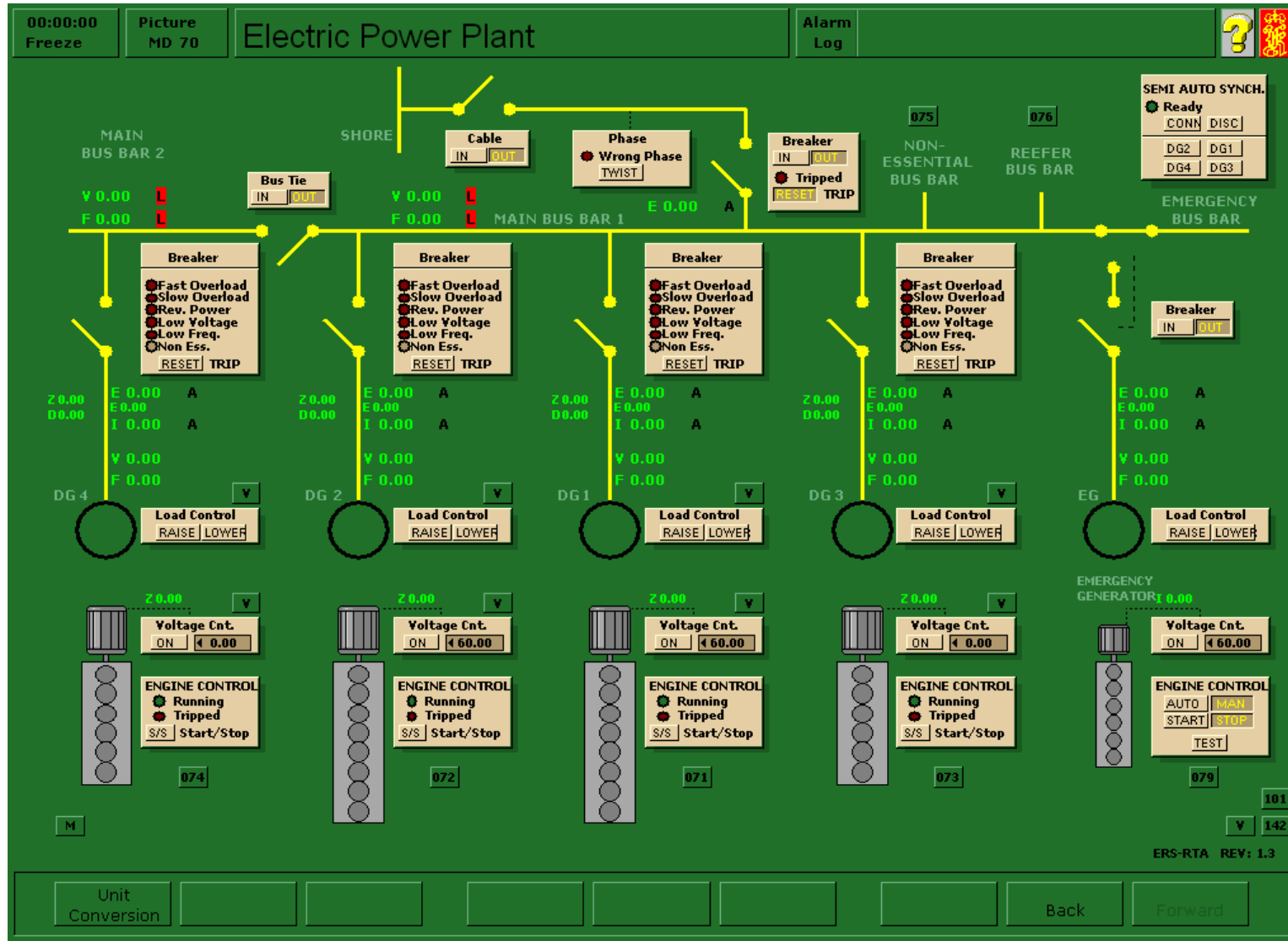



## 2.2 Electrical Power Plant

### General

The ship's electric power is generated by:

- four diesel engine driven synchronous generators - diesel generator 1 (DG1), diesel generator 2 (DG2), diesel generator 3 (DG3) and diesel generator 4 (DG4)
- one emergency generator

and distributed via:

- one main switchboard, divided into two main 440V bus bars
- one 220v bus bar
- one reefer container bus bar
- one emergency bus bar
- one 24v emergency lighting / control bus bar
- one high voltage transformer for the bow thruster

Bus bar 1 powers all the electrical main consumers including the Reefer Containers and the emergency bus bar.

Bus bar 2 powers the bow thruster and the heavy deck machinery.

The 220v bus bar is supplied from bus bar 1 via a circuit breaker and transformer.

The emergency switchboard supplies the emergency 24v bus bar through an AC/DC converter. Normal system voltage is 24 V DC. The converter and battery supply the control voltage system of the ship and the emergency light system in case of "black-out".

Emergency batteries are supplied by the AC/DC converter battery charger.

The main bus bars can also be supplied via a shore connection link that has the ability to alter phase rotation to ensure that motors turn in the correct direction.

### Description

The status of all prime movers is indicated, with the diesel generators having a remote start available.

The emergency generator can be set to either AUTO or MAN mode. It is normally kept in AUTO. The Test button starts the generator and connects the breaker while disconnecting the emergency bus bar from the main bus bar. In AUTO mode if power is lost to the emergency bus bar the generator starts and connects automatically. Reconnecting the emergency bus bar to a live main bus bar automatically stops the generator.

Each generator is excited by an AVR (automatic voltage regulator) based on a PI controller. Changing the excitation setting alters the controller base setting.

Each main generator has indication for rotor phase (between current and voltage), current angle, power factor and reactive power.

The main generators governor speed control can be accessed. All are based on a PI controller with droop setting.



All main generators are protected by a circuit breaker. The breaker protects against:

- Fast overload
- Slow overload
- Reverse power
- Low voltage

The settings of the above are easily accessed on the breaker itself. The breaker also sets the level at which the preferential trips operate, this function does not trip the circuit breaker. Whichever trip has activated is indicated and can be reset from the circuit breaker. On the main bus bar there is a connection to the emergency bus bars, a bus tie for main deck machinery and a shore connection availability.

**Note:**

The emergency generator can not be synchronised and the settings are accessed via variables page 7005.

**Normal operating modes**

Emergency generator on AUTO at all times.

-In port.

diesel generators supplying power as required, normally one can be sufficient depending on the reefer load.

-Manoeuvring.

Fixed pitch operation.

minimum two diesel generators supplying all electrical power depending on the reefer load.

-Variable pitch operation.

minimum two diesel generators supplying all electrical power depending on the reefer load.

-Sea passage

diesel generators supplying power as required, depending on the reefer load.

**Operation**

**1. Shore Connection**

- 1.1 Ensure all generators disconnected, emergency bus bar and bus tie disconnected.
- 1.2 Connect incoming cable.
- 1.3 Check phase rotation, use phase twist if required.
- 1.4 Close shore circuit breaker to supply main bus.
- 1.5 Close emergency bus if required or starting from cold and continue start sequence.
- 1.6 Shore circuit breaker must be tripped before connecting main generator to bus.

**2. Emergency Generator Starting**

- 3.1 Ensure that battery voltage is correct.
- 3.2 Generator in manual operation press START.
- 3.3 Turn on voltage control and adjust to 440v.
- 3.4 Use governor control to give 60Hz output.
- 3.5 Connect emergency generator breaker. This will trip the main bus breaker connection to the emergency bus.

**3. Emergency Generator Stopping**

- 3.1 Ensure that main bus bar has supply.





- 3.2 Connect main bus bar breaker connection to emergency bus. This will open the emergency generator breaker.
- 3.3 Stop generator.

**4. Emergency Generator Automatic Operation**

- 4.1 The generator is normally in AUTO, voltage control on, circuit breaker open.
- 4.2 If supply is lost to the emergency switchboard the generator will automatically start and close the circuit breaker supplying the emergency bus.
- 4.3 The main bus will be isolated due to the connection circuit breaker opening on low voltage.
- 4.4 When the emergency bus is again supplied from the main bus, connection circuit breaker closed, the emergency generator circuit breaker will automatically open and the generator will stop.

**5. Emergency Generator Testing**

- 5.1 The generator should be tested regularly to ensure that it will function when required.
- 5.2 With the generator in AUTO, setting the TEST button will simulate low voltage on the emergency bus causing the generator to start and change over circuit breakers.
- 5.3 The generator will attempt a maximum of three starts.
- 5.4 Un-setting the TEST button changes the circuit breakers over and the generator stops.

**6. Main Generators**

- 6.1 It is normal to have the generators in AUTO and priorities set on diesel generators so that load sharing is achieved as the control mode dictates.
- 6.2 With generators not in AUTO mode connection can be made from the main switchboard.
- 6.3 Before attempting connection check that the generator is ready to run.
- 6.4 Ensure that voltage control is on.
- 6.5 Start required generator by pressing start/stop button.
- 6.6 When engine is running, adjust voltage control if necessary to match main bus voltage.
- 6.7 The breaker can be made by the semi auto sync – select generator and adjust speed until ready light shows, press connect.
- 6.8 Once connected the generators must be manually operated to share the load by adjusting the governor controls.
- 6.9 To disconnect, select generator to be stopped, remove load by lowering the governor control, press disc.
- 6.10 After disconnection, the generator can be stopped by pressing the start/stop button.
- 6.11 Synchronising and load sharing can also be carried out using the Power-chief generator control panel.

00:49:56  
Running
Picture MD 141

## Main Switchboard - Diesel Gen. 2

Alarm Log 1 17

FREQUENCY

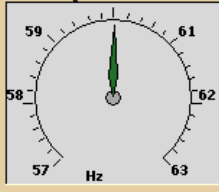

60.03

Synchroscope

VOLTAGE

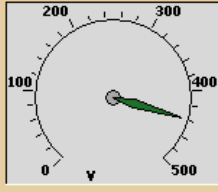

440.08

R-S   S-T   T-R

CURRENT

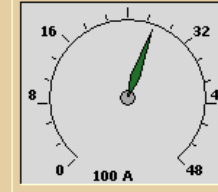

2743.2

R   S   T

POWER

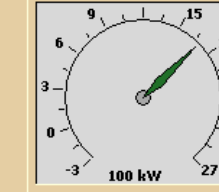

1700.5

REACTIVE POWER

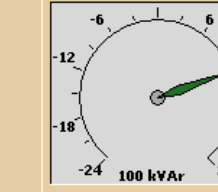

1216.7

kVAr   PF

  

Generator Breaker

Trip
Reset
Ready

- Pretrip Alarm
- Overload
- Reverse Power
- Low Voltage
- Low Frequency

Excitation

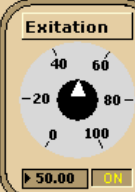

50.00   ON

Circuit Breaker

DISC
CONN



Ready
Stop
Start
RUN

DG2

IN

Governor

DECR
INCR



070
101

ERS-RTA-III   REV: 1.0

Unit Conversion

Message Log

Back

Forward



## 2.3 Main Switchboard

### General.

Voltage and frequency readings of the Generator bus bar are available on the panel. Together with speed adjustment, the operator is allowed to connect the generator with verification of synchronizing to the main bus bar.

The Diesel Generator section contains meters for:

- frequency
- volts
- current
- active power
- reactive power

Selector switches for voltage and current meters allow reading of individual phase values.

The reactive power can be measured in kVA or power factor.

Generator excitation and speed can be adjusted, generator stopped and started, circuit breaker opened and closed.

Before the generator may be started or stopped the READY light must be illuminated.

The state of the main circuit breaker trips are indicated and may be reset from this panel. Before attempting synchronisation the breaker ready light must be illuminated.



By selecting Synchroscope the synchronising panel is shown, displaying Bus frequency and voltage, and incoming generator frequency and voltage. By selecting the incoming generator then synchronising may be carried out manually.

The synchroscope should be switched off after use. And the load shared manually by adjusting the governor speed.

00:51:08  
Running
Picture MD 142

## Main Switchboard - Synchronising

Alarm Log 1 17

  

Bus Voltage (V)

Generator Voltage (V)

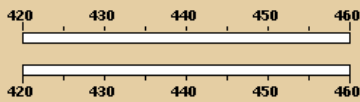

SYNCHROSCOPE

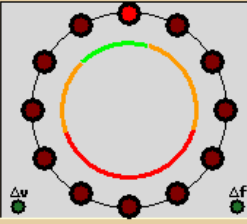

Bus Frequency (Hz)

Generator Frequency (Hz)

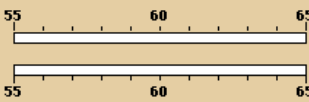

Shore Supply



Shore Cable

DISC CONN

Wrong Way Change Phase

Circuit Breaker

DISC CONN

Synchroscope

DG1 DG3  
DG2  
DG4  
off

Earth Leakage Monitor

RESISTANCE

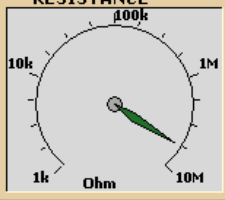

Phase Select

R S T

440V 220V

SemiAutomatic Synchronising

Ready Start

Generator Selection

DG1 DG3  
DG2  
DG4  
off

Waiting  
Breaker Connected

070 101
ERS-RTA-III REV: 1.0

Unit Conversion

Message Log

Back

Forward



---

## 2.4 Main Switchboard – Synchronising

### General

The synchronising panel allows semi-automatic synchronising of generators and connection of shore supply.

Shore supply connection should be to a 'dead' bus-bar. Connecting the shore cables activates the phase check to ensure that the vessels motors will run in the correct direction. If the wrong phase rotation is detected the phases of the shore connection may be changed before connecting the shore supply to the bus-bars.

Semi-automatic synchronising is carried out by selecting the incoming generator and pressing the start button. Indication is given when main circuit breaker is closed. The load should be shared manually.

This panel also shows the resistance to earth of each phase by selecting the R S T button. Earth resistance is indicated for both 440v and 220v bus.

00:38:31  
Running
Picture MD 101

## Power Chief - Generator Control

Alarm 1

?

Diesel Generator 4

kA

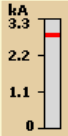

POWER

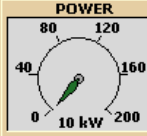

DECR COM
ADJUS SPEED
SYNC
LOAD
UN-LOAD
INCR COM

STOP

DIS-CONN

READY

Prior 1

RUN

IN

Prior 2

START

CONN

AUTO

Prior 3

074

Diesel Generator 2

kA

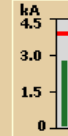

POWER

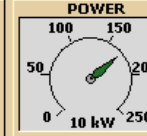

DECR COM
ADJUS SPEED
SYNC
LOAD
UN-LOAD
INCR COM

STOP

DIS-CONN

READY

Prior 1

RUN

IN

Prior 2

START

CONN

AUTO

Prior 3

072

Diesel Generator 1

kA

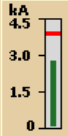

POWER

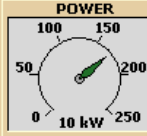

DECR COM
ADJUS SPEED
SYNC
LOAD
UN-LOAD
INCR COM

STOP

DIS-CONN

READY

Prior 1

RUN

IN

Prior 2

START

CONN

AUTO

Prior 3

071

Diesel Generator 3

kA

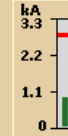

POWER

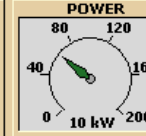

DECR COM
ADJUS SPEED
SYNC
LOAD
UN-LOAD
INCR COM

STOP

DIS-CONN

READY

Prior 1

RUN

IN

Prior 2

START

CONN

AUTO

Prior 3

073

v v

Control Mode
Alarms

Equal Load

Optim Load

Cyclic Load

Alert Mode

Non Ess Trip

High Power

Gen S/S Req

Power Chief Load Diagram

Power Chief

Generator Control

070

v 142

ERS-RTA REV: 1.2

Unit Conversion

Message Log

Back

Forward



## 2.5 Power Chief – Generator Control

### General

The consumption of and demand for electric power is constantly monitored and compared to the present possible power production. When deviation from preset limits arises, the system will act in order to normalize the situation. Thereby the possibility for black-out is reduced and a more economical use of the auxiliary engines is achieved. The system also performs continuous control of the frequency and load-sharing.

The active power of each individual generator is indicated along with a bar graph of current with maximum setting indicated.

The following commands are available from the PowerChief - Generator Control panel:

- Remote Start/Stop of Diesel Generators
- Remote Connect/Disconnect of all generators
- Automatic Control of demand for power with three different control modes of load-sharing:
  - Equal, Optimum and Cyclic mode
- Priority selection
- Non Essential Trip

### 1 Remote Start/Stop and Connect/Disconnect.

- 1.1 With generator in manual, ensure that READY light is lit.
- 1.2 Press Start and generator is remotely started and RUN light indicates when generator is running at correct speed.

- 1.3 Press Connect and automatic synchronisation occurs, main breaker id connected and IN is lit.
- 1.4 Manual load sharing is required.
- 1.5 To shut down generator press Disconnect to open main circuit breaker when load has been reduced to zero and then stop the generator.

### Load Sharing Modes.

#### Equal Mode

- the active load is shared among the running generators evenly as a proportion of the maximum load of the individual generators. The Power Chief Load Diagram indicates the %load of each generator and shows the load levels at which automatic stopping and starting of generators will occur. As the total load increases generators will be started according to their selected priority to ensure that overload conditions are avoided. As load decreases generators will be shed, lowest priority first, in order to maximise efficiency of the plant.
- By selecting Alert Mode the automatic shedding of generators is prevented and should be used for stand-by conditions when an excess of power is required by SOLAS regulations and when there is expected to be sudden, very large, power demands such as using the bow thruster.

#### Optimum Mode.

- the generators are managed to optimise the efficiency of the plant. The highest priority generator will maintain a high load to ensure best efficiency. Load variation will be taken by the lowest priority, running generator. The PowerChief Load Diagram indicates the load levels for start and stop of generators.



- By selecting Cyclic Mode the generator taking the increase/decrease in load is changed at a predetermined time. This helps to prevent fouling of the exhaust system due to operation on HFO for long periods.

In order for the automatic load control to operate the generators must:

- have READY lit
- be in AUTO
- have priority selected

If a critical alarm arises while a generator is in AUTO and connected, a new generator will be started and connected before the generator with problems is disconnected. If no stand by generator is available, the alarmed generator will be taken out of AUTO control (indicated by flashing AUTO) but kept connected.

Diesel generators that are in AUTO mode and not connected within a given period, will be stopped.

The following alarms are diesel generator critical alarms:

Fw temp outlet DG	high
Fw pressure inlet DG	low
Exhaust temp inlet TBCH	high
Exhaust temp outlet TBCH	high
Air temp outlet AIRC	high
FO filter dp	high
LO press inlet DG	low
LO temp inlet DG	high
bearing temp fwd	high
bearing temp aft	high

**Non-Essential Trip.**

This is lit should the non essential trip activate to reduce the total load on the bus-bars helping to prevent blackout occurring.

**High Power.**

This lamp is on when the power rating is higher than normal rating for the generator, giving warning of possible non-essential trip or blackout.

**Gen S/S Req**

Lit when power requirements need start or stop of generator.

**Blackout Recovery.**

Should blackout occur, generators are started and reconnected according to their selected priority.



<This page is intentionally left blank>

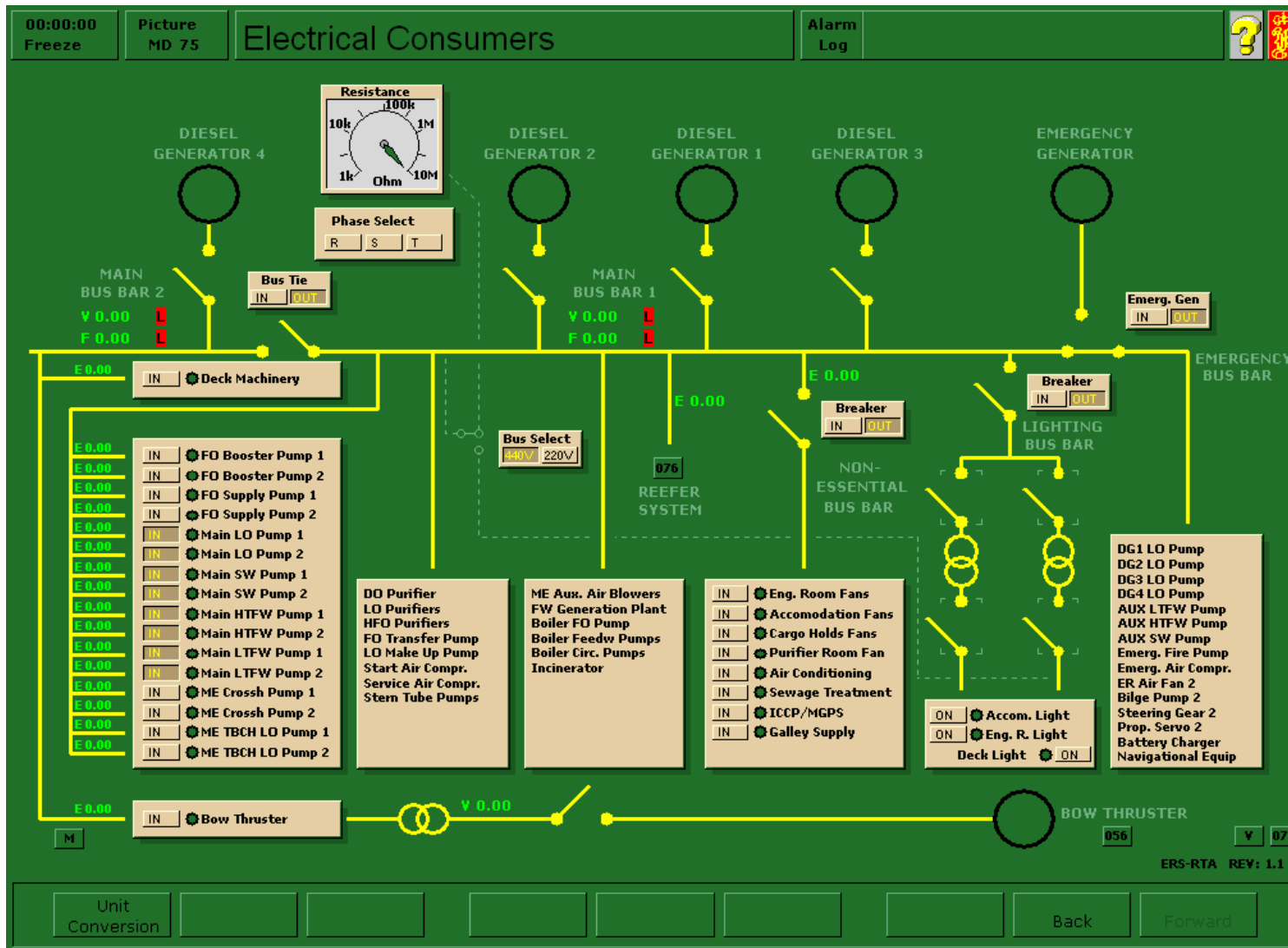



---

## 2.6 Electrical Consumers

### General

The starters are grouped into five main sections. Deck machinery and bow thruster are supplied via a bus tie.

The breakers are operated by pressing the IN button. Pressing IN again will open the breaker. The green indicator shows if the machinery is running.

The display value of the breakers may be changed from active power to current.

Total Earth Leakage current is constantly monitored. Earth faultfinding is available by selecting 440v or 220v distribution system and switching between phases.

In case of overload of available supply the breakers for non essential bus bar will automatically disconnect. Non essential must be circuits not required for the safe operation of the vessel.

Non-Essentials trip as dictated by the settings on the generator breakers (variable page 7500).

### The bow thruster

The Thruster is supplied through a 440/3300v transformer and it is possible with the thruster in local mode to set the power chief in “alert mode”, and when green light for ready is on, it is possible to start the thrusters and set the responsibility in “bridge mode”.

It is possible to run the thrusters in local mode from the engine room by two push buttons.

### Note

For safety it is important to start minimum two diesel generators depending of the reefer container load, before starting the bow thrusters.

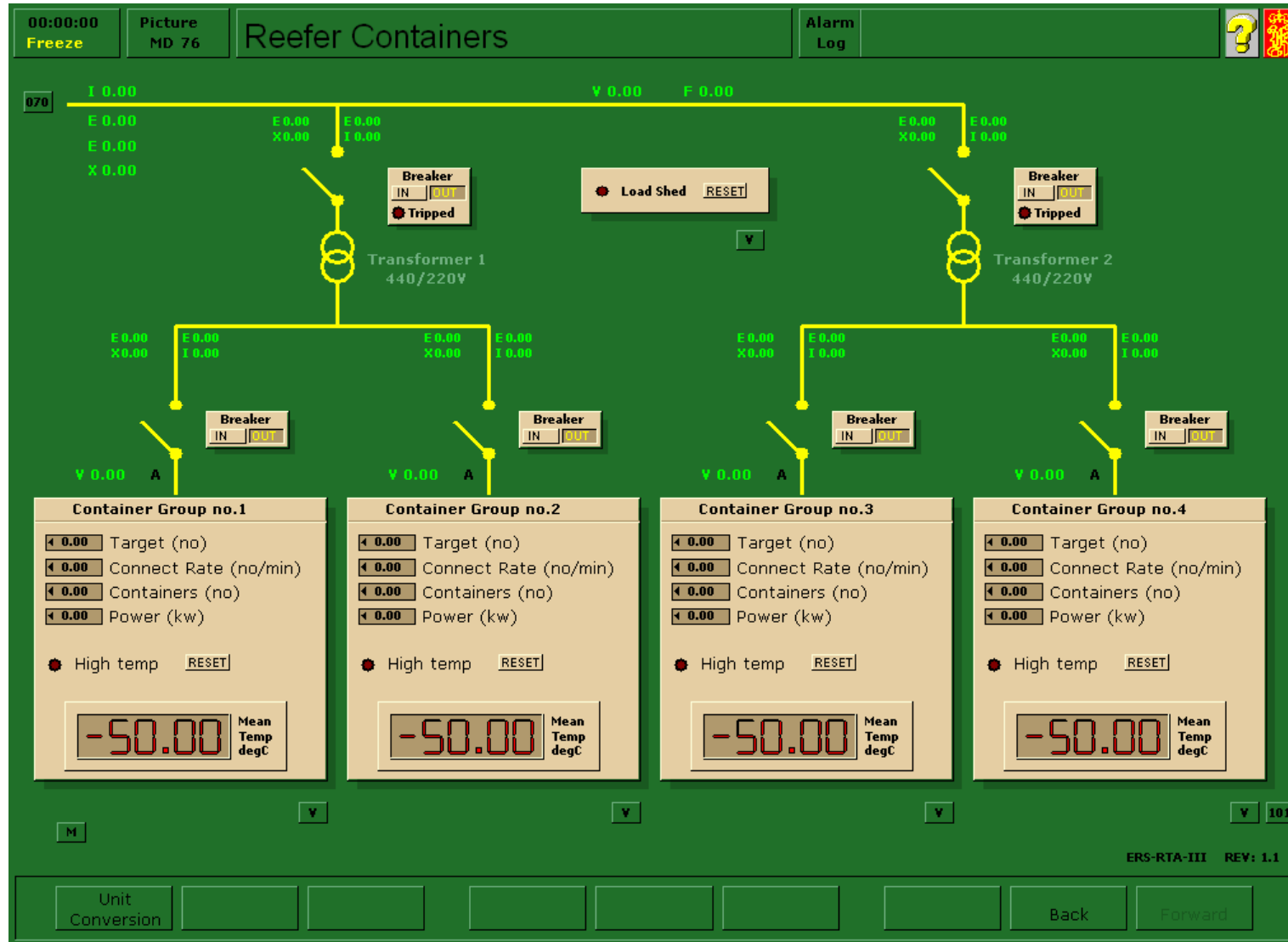



## 2.7 Reefer Container

### General

The reefer container bus bar is grouped into two main sections.

Each section consists of one 440/220V transformer and two container groups with a circuit breaker.

Each container group is fed from the bus bar via a circuit breaker and 150 reefers can be connected in the power plugs.

High limit for the breaker is 5000 A (variable page 7601, 7602, 7603 and 7604).

Each container group has indication for current, active power, reactive power and power factor.

The breakers are operated by pressing the IN/OUT button.

It is possible to set a “target number” of reefers and a “connect rate” (that means how many reefers the electrician can plug in per minute, normally 2-3 reefers/min). When reefers are plugged in, it is shown in the container group, and when the breaker is connected, the total power for the group can be read.

The temperature is the mean temperature in degC for all the reefers in this group.

### Note

Before loading reefers it is important to keep an eye on the total power consumption and the maximum power of the connected diesel generators.

Remember it is important to inform the cargo control officer if the reefers are disconnected under manoeuvre or troubles with the power supply.

Reefer Containers will trip at overload of generators. The trip sequences can be set up as follows:

C15581 = 0 The highest loaded group will trip first.

C15581 = 1 The highest loaded main breaker will trip first.

C15581 = 2 All reefer containers will trip.

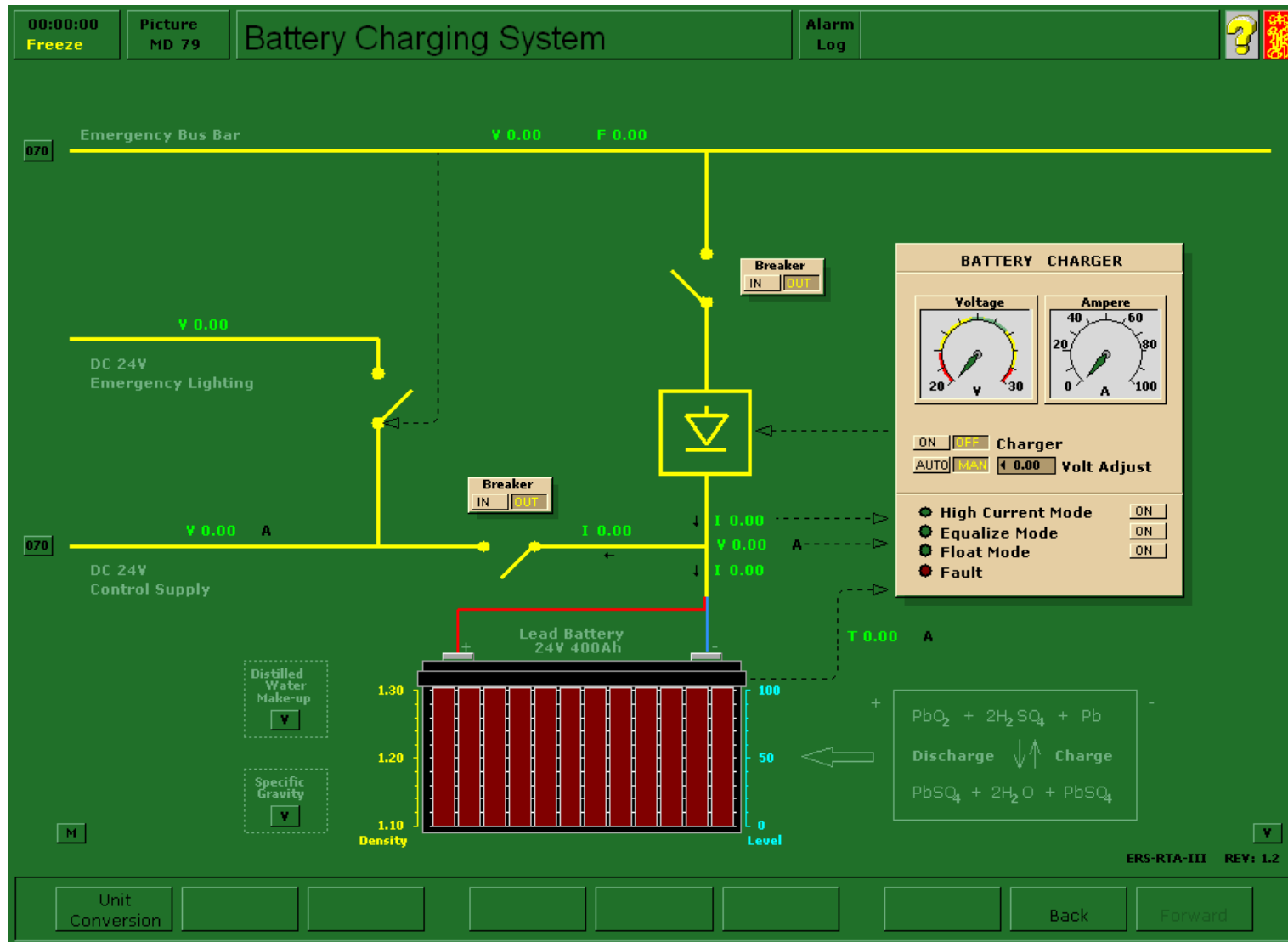



## 2.8 Battery Charging System

### General

The battery system consists of a number of batteries with a total capacity of 440 Ah. The battery system is supplied from the emergency switchboard 440 V AC section, through an AC/DC converter. Normal system voltage is 24 V DC. The converter and battery supply the control voltage system of the ship and the emergency light system in case of “black-out”. The emergency light system is automatically connected in case of low voltage at the emergency switchboard and is reconnected when the voltage is normal at the emergency switchboard again.

### 2.8.1 Operation

The converter is controlled either automatically or manually. In automatic operation the converter switches between:

- High Current Mode – set point 30 V
- Equalize Mode – set point 29,5 V
- Float Mode – set point 26,9 V

The converter compensates for the temperature in the electrolyte through a correction of the charging voltage.

In manual operation the three modes can be selected, or the required charging voltage can be keyed in within the interval 5 to 35 V.

The lead accumulator can be refilled with distilled water by using the short cut key to the variable list. (Give the variable X14401 status = 1).

### 2.8.2 Fault and restart of the system

Charger fault will be activated by timeout at High Current Mode. A high external battery load could cause this. If the battery temperature exceeds high temp limit, the charger also transfers to fail.

At charger failure, output current is shut off. Reset charger fault by turning the battery charger off/on.



## 2.9 Emergency Switchboard

### General

The emergency switchboard supplies circuits necessary for the safety of the vessel. These include communications, navigation lights, fire alarm, fire and flood control.

The emergency bus bar has indication for current, voltage, active power, reactive power and frequency.

The emergency battery is supplied by a battery charger via the 440V emergency bus bar.

The consumers connected to the emergency bus bar are:

- DG1 LO Pump
- DG2 LO Pump
- DG3 LO Pump
- DG4 LO Pump
- AUX LTFW Pump
- AUX HTFW Pump
- AUX SW Pump
- Emerg. Fire Pump
- Emerg. Air Compr.
- ER Air Fan 2
- Bilge Pump 2
- Steering Gear 2
- Prop. Servo 2

- Battery Charger
- Navigational Equip

The emergency generator cannot be synchronized with the other generators, there is an interlock between the main bus bar and the emergency bus bar for this purpose.

The emergency generator can be started and stopped in manual mode or AUTO mode.

In AUTO the diesel generator will start up if a black-out occurs, the breaker between the main bus bar and the emergency bus bar will disconnect and the emergency generators circuit breaker will connect the generator to the emergency bus bar.

When the emergency generator has been disconnected, it will stop after a few minutes and again be ready for a new start-up if necessary.

### Test function

There is a test function.

Pressing the test button means that the diesel generator will start up and be connected to the emergency bus bar after disconnecting the main bus bar.

The test function will be stopped by pressing the test button. The emergency generator will be disconnected and the main bus bar will again supply the emergency bus bar.





### 3 MAIN ENGINE AND MAIN ENGINE SYSTEMS

#### 3.1 Main Engine

The propulsion machinery is based on a Sulzer RTA84(C), low speed, 12 cylinder configuration, 2-stroke, turbocharged, reversible diesel engine. The main engine is coupled to a propeller shaft with both fixed pitch propeller and controllable pitch propeller (selectable by the instructor).

##### Main engine data:

-	Type	Sulzer RTA84C
-	Cyl Bore	840 mm
-	Piston Stroke	2400 mm
-	Number of Cylinders	12
-	Number of Air Coolers	3
-	Number of Turbo Chargers	3
-	Continuous Service Rating ME	48.6 MW
-	Corresponding Engine Speed	102 rpm
-	Mean Indicated Pressure	17.0 Bar
-	Scavenge Air Pressure	2.4 Bar
-	Turbine Speed	9500 rpm
-	Number of Prop. Blades	5
-	Propeller Pitch	0.9 P/D
-	Specific Fuel Oil Consumption	165 g/kwh

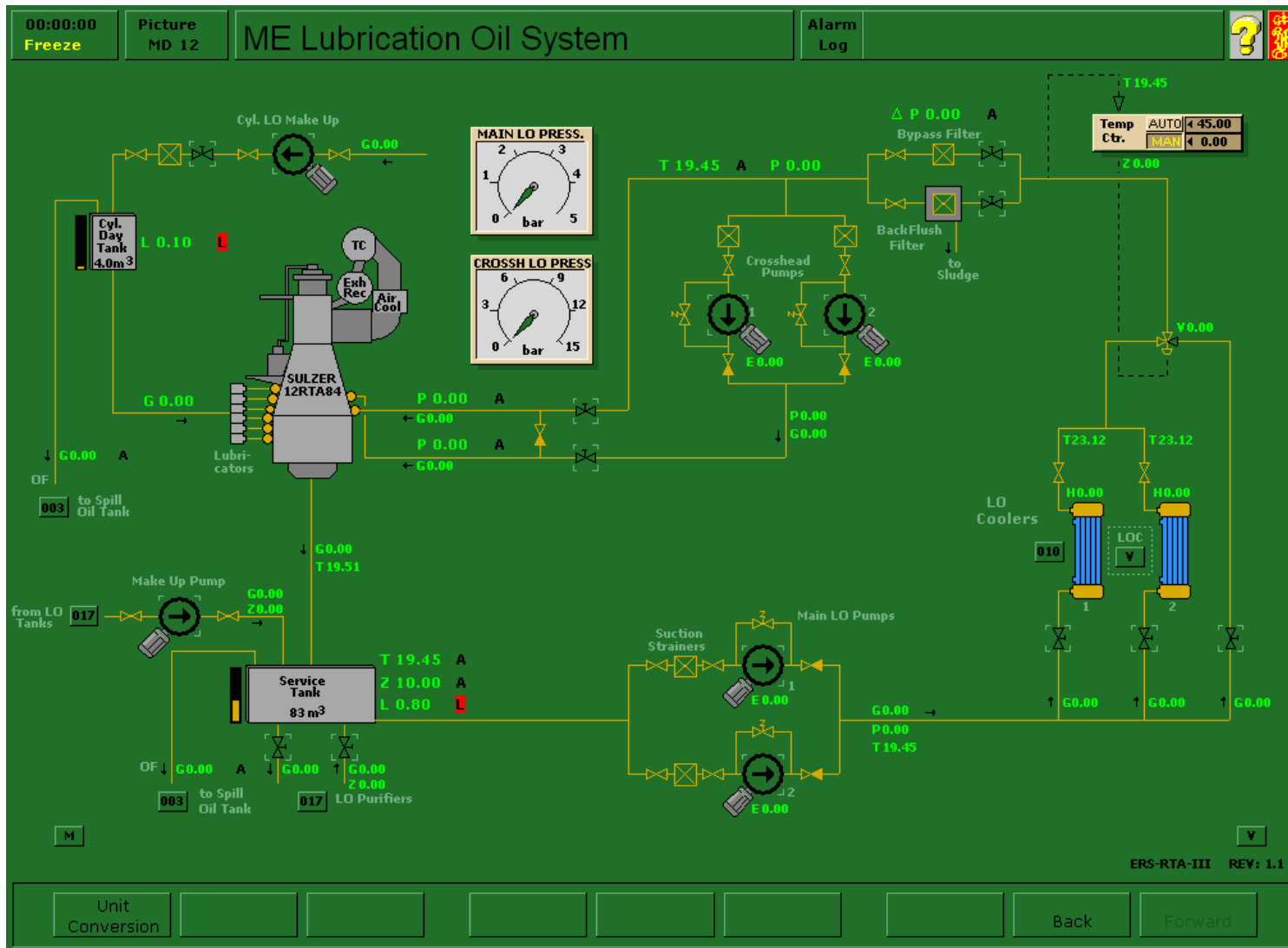



## 3.2 ME Lubrication Oil System

### General

The oil pressure which is necessary for the main bearing lubrication is raised by the main LO pumps and for the crosshead bearings is raised by the crosshead LO pumps. The main bearing and crosshead bearing LO systems are interconnected through a non-return valve.

Main bearing oil is also used via an articulated lever to cool the working piston crown.

The normal operating pressure for the main bearing is 3.4-4.2 bar, while the operating pressure for the crosshead bearing is 10-12 bar. Should the crosshead pump fail, the crosshead bearings will be supplied from the main bearing oil system through the non-return valve. ME can only be operated at low load under such conditions.

The crosshead bearing oil is further used for exhaust valve spindle lubrication and as drive for the cylinder lubricator.

The oil for exhaust valve actuator pumps passes from the crosshead bearing oil system through an air purifier. For actuating the exhaust valves, the oil pressure is raised by the actuator pumps to about 160 bar.

The lubrication oil from the main engine sump is collected in a service tank below the engine.

The LO pumps are protected by a pressure relief valve which opens for pressure over a preset value.

The service tank oil can also be cleaned in a LO purifier.

A make-up pump enters new oil with flow directly to the service tank.

The lubrication oil is cooled in two LT fresh water cooled LO coolers and is then passing a double filter before it enters the main engine. The LO temperature is controlled by a PI controller, which regulates a by-pass valve for the LO coolers.

The LO filters must be cleaned regularly to avoid pressure/flow reduction.

### Cylinder Lubrication

The cylinder day tank has a volume on 4.0 m<sup>3</sup> and there is a cylinder LO make up pump to refill the day tank. The make up pump takes suction from the cylinder LO storage tank.

At low cylinder LO tank level there will be ME slow down/shut down.

It is possible to adjust each cylinder lubricator individually from the individual cylinder screen.



## Operation procedures

### Start up for main engine

- Ensure that main engine sump has sufficient oil.
- Set temperature controller in AUTO at 45°C.
- Ensure that suction and delivery valves on both main lube oil pumps are open.
- Ensure that one cooler has inlet and outlet valves open.
- Ensure that inlet and outlet valves to back flush filter are open.
- Ensure that main bearing supply valve is open.
- Start one of the main lube oil pumps in manual, wait until the lube oil pressure has risen to about 3 bar. Then set pump control to auto in pump/compressor Auto chief page.
- It should only be necessary for one pump to be running with the other in standby.
- Ensure that oil is flowing to main bearings and piston cooling at correct temp.

### Start up cross head LO supply

One pump started manually after opening valves, then switch to AUTO when pressure reaches about 8 bar.

### Start up for cylinder LO system

Ensure as a minimum 0.5m<sup>3</sup> in the cylinder oil day tank.

Check that all relevant valves are open.

The flow will vary with engine speed.

### Normal stop procedure

When engine has stopped at Finished with Engines, wait for approx 30 minutes to ensure that engine has cooled down and stop all lube oil pumps. Sump temperature in port is normally maintained by continually running the lube oil purifier.

### Note

Before starting ME, always check the main- and the cross head LO pressure.

On the picture MD 19 it is possible to see the slow- and shutdowns for LO pressure.



<This page is intentionally left blank>

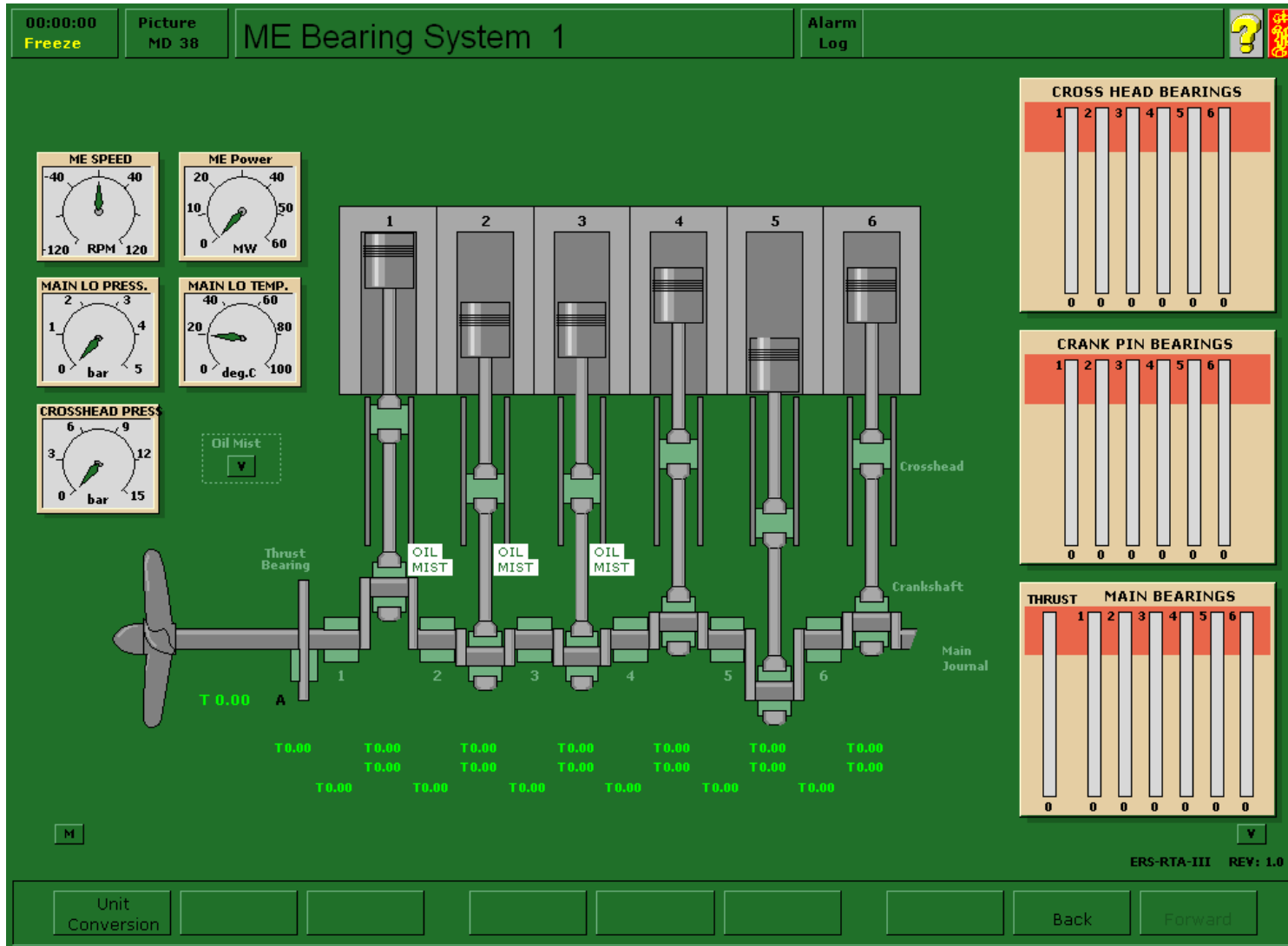



### 3.3 ME Bearings

#### General

The screen provides the operator with a clear display of all bearing temperatures within the engine, as well as the main parameters that affect bearing load, such as main engine speed, engine power, and the lubricating oil supply.

The bearings temperature shown are:

- Cross head bearing
- Crank pin bearings
- Main bearings
- Thrust bearing

Comparisons between the various bearings can be easily made, and should a bearing temperature increase above 90°C, then the indicating bar will change to red to aid identification. At the same time the bearing concerned will also change colour to red.

The screen will also display the presence of oil mist within the crankcase, as well as which units are affected. Should oil mist be detected, then the engine protection system will activate, and an engine slow down will occur.

Variable page 3810 shows the oil mist detection for each cylinder.

#### Oil mist alarm

The Sulzer procedures for reaction to an oil mist alarm, or other alarms that could lead to the oil mist situation are:

1. Reduce engine power/pitch down to slow-down level, if this is not an automatic function. This will drastically reduce the load on the engine bearings, and hence the production of oil mist.
2. Contact bridge, and ask to STOP engine. If the vessel is in a confined area, it may not be possible to stop the vessel. Hence the engine would continue on **minimal power**.
3. When stop order is received, stop the engine and close the fuel supply to the engine by stopping the booster pumps.
4. Switch off the auxiliary blowers.
5. Open engine room casing. This will reduce the pressure rise in the engine room, should the crankcase relief devices operate.
6. Personnel to vacate engine room. This is for the personnel safety of the engine room staff should flames issue from the relief valves. It may be prudent to have a minimal staff in the control room to monitor the situation, and to maintain the main services, but under no circumstances should personnel operate on the engine.
7. Prepare fire fighting equipment. A safety precaution against outbreaks of fire in the engine room, from any flames issuing from the crankcase relief doors.
8. **Do not open the crankcase until after at least 20 minutes.** You must allow time for the oil mist to cool and fully condense.



It is also recommended that the oil mist detector alarm level should reset, which indicates that the oil mist levels are well below the Lower Explosive Limit. Obviously no naked flames should be used on the initial entry.

9. Stop all lube oil pumps. To allow personnel entry into the crankcase.

10. Isolate the starting air, and engage the turning gear.

11. Open the crankcase doors, and inspect the following areas for overheating:

- Main and bottom end bearings
- Thrust bearing
- Crosshead bearings
- Piston rods
- Stuffing boxes
- Gears
- Vibration dampers

- Moment compensators
- Articulated pipes
- Cracked piston crown, allowing oil mist to enter crankcase via cooling oil return
- Overheated diaphragm, from a scavenge fire

12. Overheating can be identified by:

- Melted or squeezed white metal from the bearings
- Discoloration of the crankcase paint in the vicinity burnt or carbonized oil deposits
- Excessive bearing clearances
- Excessive oil flow from a bearing



<This page is intentionally left blank>

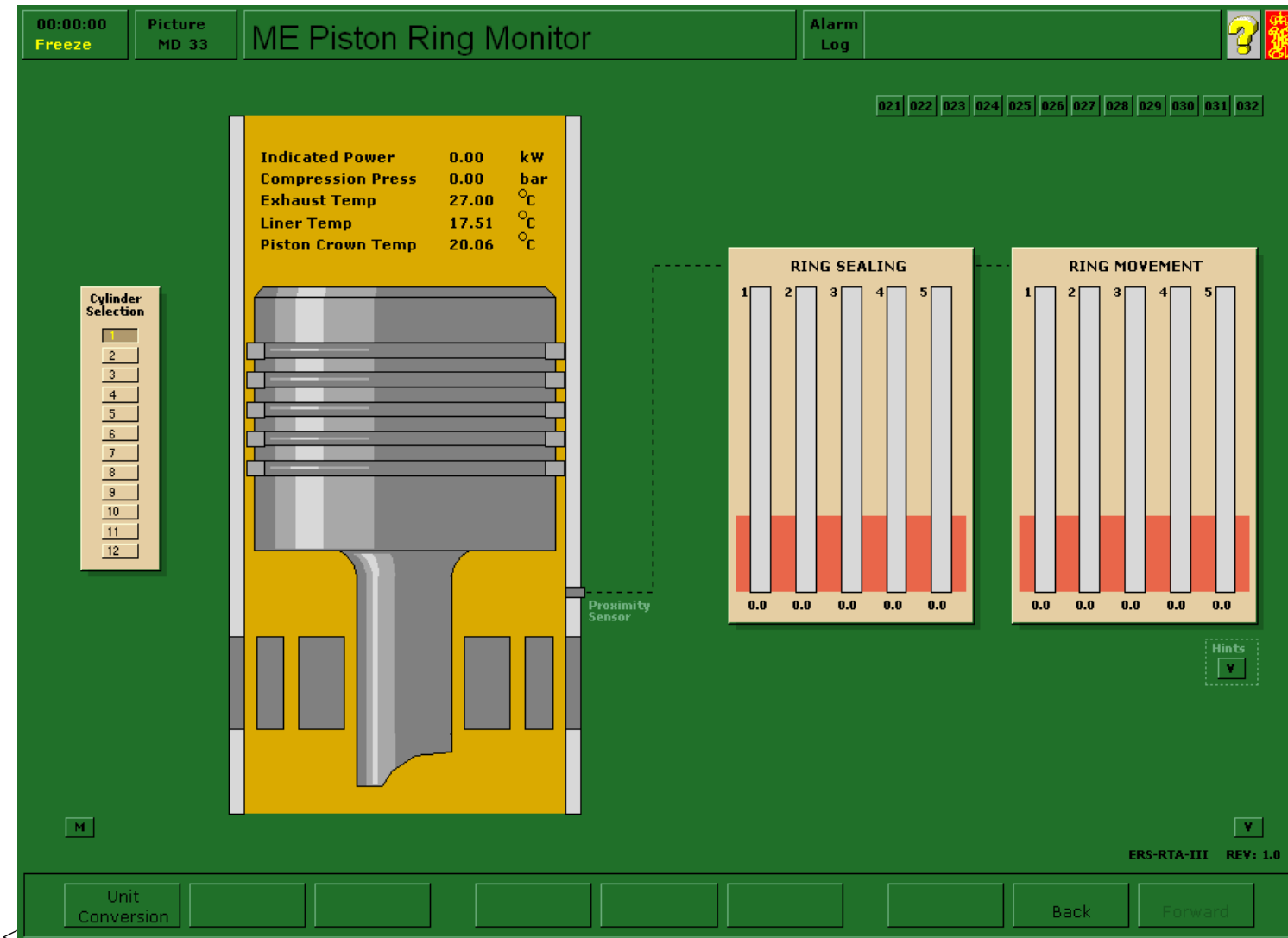



---

### 3.4 ME Piston Ring Monitor

#### General

The screen provides an indication of the piston ring condition within each cylinder. Two bar charts are provided for each cylinder. The cylinder can be selected, and provides a display for each piston ring for sealing and movement.

Under normal circumstances the ring sealing and movement will be high. Should the ring wear increase then ring sealing will reduce,

whereas should the cylinder lubrication be reduced, then the ring movement will reduce.

When the ring sealing and movement reduces below an acceptable level, then an alarm will be activated.

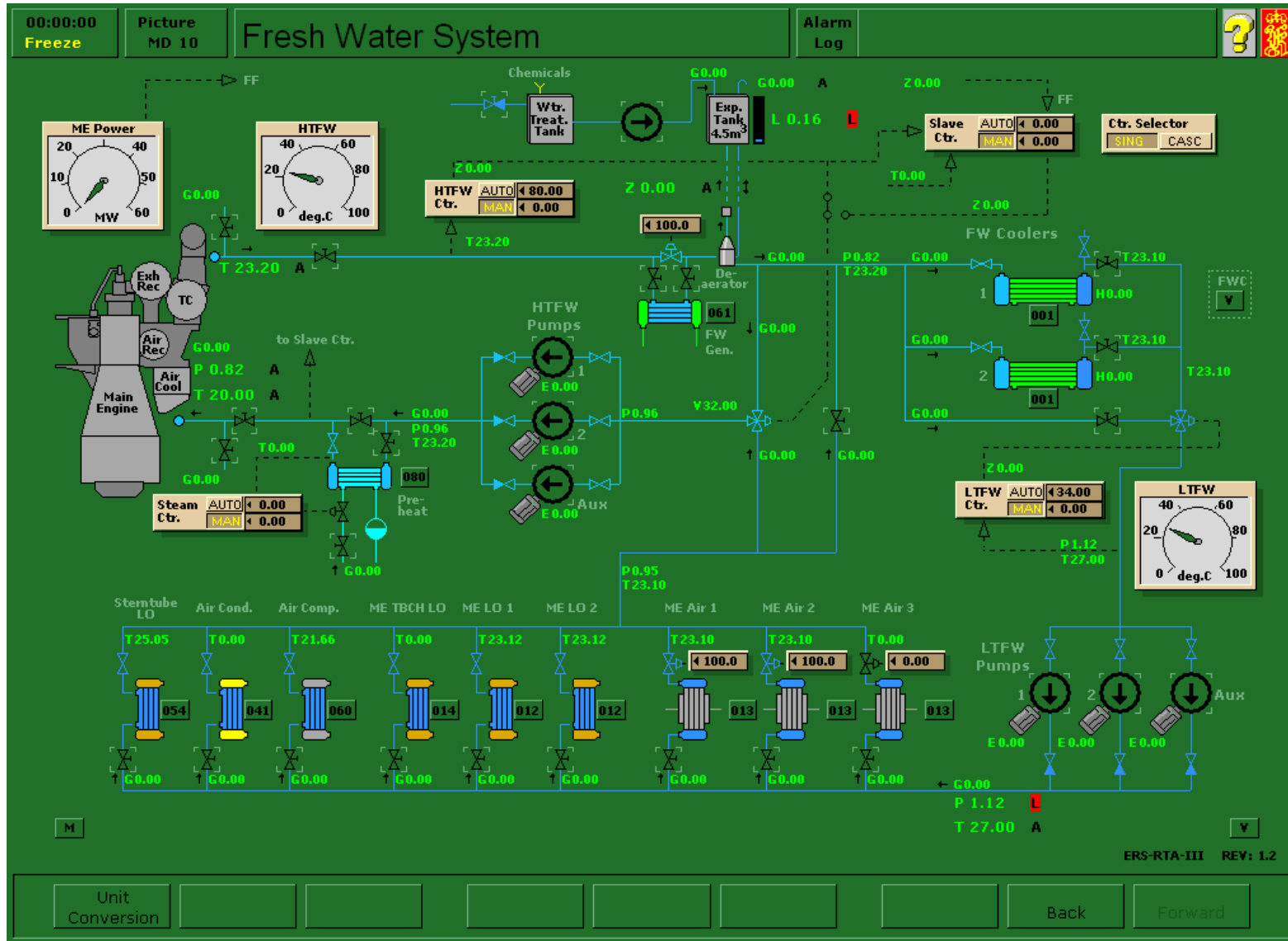



### 3.5 Fresh Water System

#### General

The fresh water cooling system is separated in two subsystems:

- Low Temperature System
- High Temperature System

The Low Temperature Fresh Water (LTFW) system cools all auxiliary equipment, such as:

- the start- and service air compressors
- Air condition condenser
- stern tube and propeller servo oil system
- main engine air cooling system
- cooling of the oil in the cross head and main engine lub. oil system.

The LTFW pumps (normally only one in operation), pump the fresh water through the above mentioned coolers. The FW system is cooled by the SW system. The auxiliary LTFW pump is mainly used when in harbour or during blackout.

The fresh water temperature in the LTFW system is controlled by a PID controller, which actuates a three-way mixing valve, placed after the two fresh water coolers. This controller can be operated in manual or auto mode. The controller input signal is given by the temperature before the LTFW pumps.

From the LT/HT junction, some of the LTFW is led directly to the FW coolers, while some is led to the HTFW loop.

The High Temperature fresh water cools the liners of the main engine. Some of the excessive heat is used for heating the fresh water generator. The fresh water through the main engine is driven by two main and one auxiliary HTFW pumps, of which only one of the main pumps is normally in operation. The auxiliary pump is provided for in port use. If the HTFW pumps stop, a small cooling medium flow will still be present as long as one of the LTFW pumps is running. If the main engine has been stopped for a long period of time, it is required to permit the HTFW flow to pass the pre-heater, which is supplied with steam.

The auxiliary HTFW pump is mainly used when in harbour or during blackout.

The HTFW system is controlled by a PID controller and a slave controller, which operates a three way mixing valve, mixing hot water from main engine outlet with cold water from the LT/HT junction. It is possible to run the PID controller in single or cascade mode. In cascade mode the slave controller gets a feed forward signal from the engines load. (For further information about controllers, please refer to operator's manual part 2).



## Operation procedure

### 1. Pre-heating

- 1.1 During out of service periods or if stopped for a prolonged period during manoeuvre the main engine must be pre-heated. Insufficient pre-heating of the main engine before starting may cause misalignment of the main bearings and fresh water leaking.
- 1.2 Line up the pre-heating of the ME and start the preheating circulation pump.
- 1.3 Correct pre-heating temperature is 70°C.

### 2. Jacket cooling water loop

- 2.1 Check the position of all valves in suction and discharge line and start the electrical auxiliary jacket cooling water pump locally.
- 2.2 Check sea - and LT fresh water cooling system is in operation.
- 2.3 Check the temperature controller. Normal temperature controller set point is 85°C.
- 2.4 Change to main HTFW pump and put the pump set to AUTO.
- 2.5 During normal operation with engine running the pre-heater would be shut off.
- 2.6 The expansion tank level should be checked periodically.

### 3. Normal stop procedure

- 3.1 Prior to stopping the engine the fresh water generator must be secured and the jacket cooling water bye-pass opened to prevent under cooling of the jackets during manoeuvring.
- 3.2 During short stops the main HTFW pump may be left running and the jacket pre-heater put in use.
- 3.3 For longer stops use the auxiliary HTFW pump and the jacket pre-heater.
- 3.4 If securing the engine for maintenance shut off steam to the pre-heater until temperature has cooled to about 40°C or ambient engine temperature and stop all pumps.

To secure the LTFW system the plant must be shut down and LTFW pumps stopped.

#### Note:

When stopping the fresh water generator it is very important to open the by-pass first before closing the valves to the evaporator otherwise the ME will get a shut down signal and stop.

<This page is intentionally left blank>

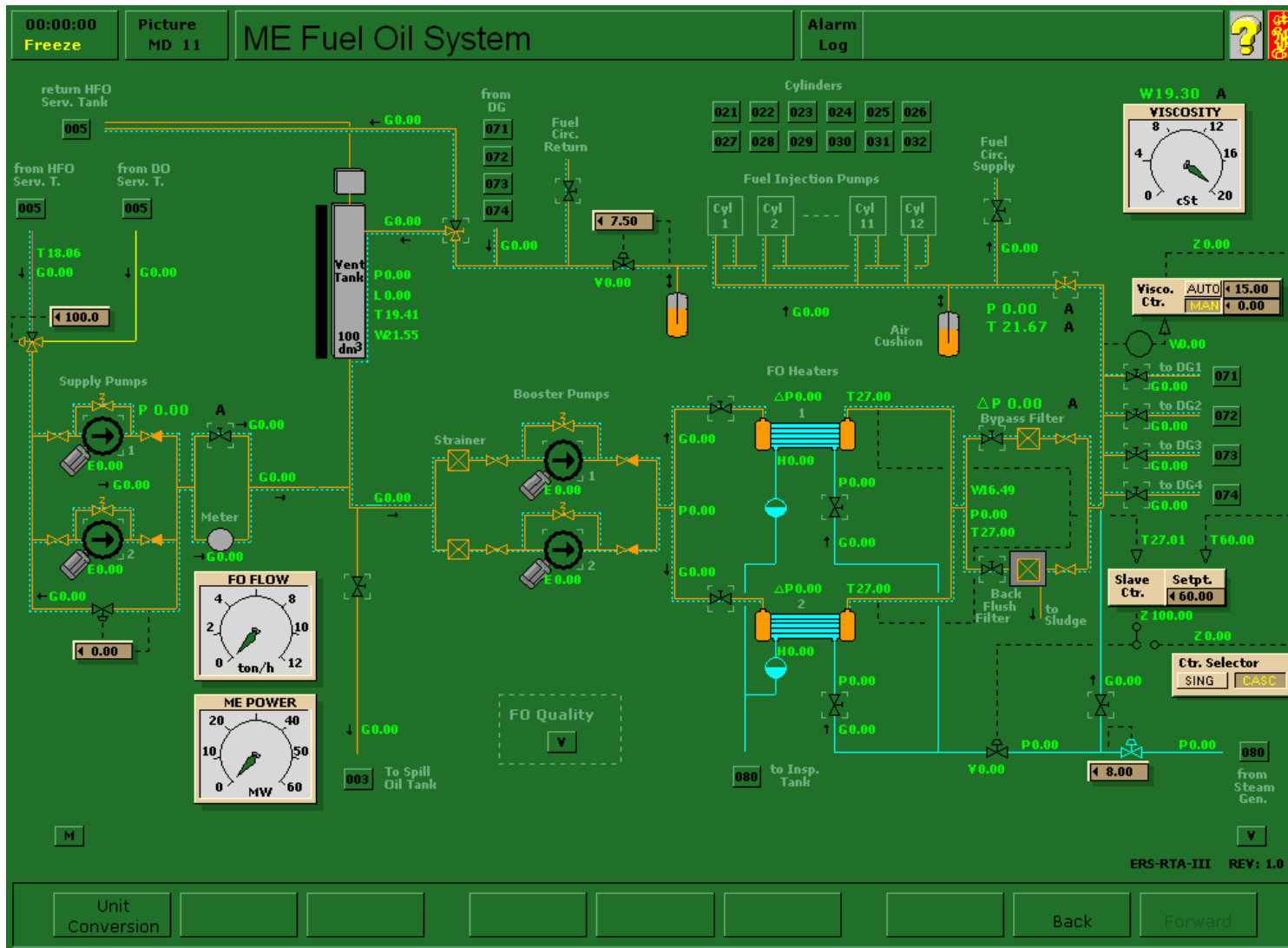



## 3.6 Fuel Oil System

### General

The purpose of the fuel oil service system is to preheat the fuel oil to correct injection viscosity, to fine-filter the fuel oil and to supply the main engines and the diesel generators with a continuous flow of fuel oil at a correct pressure.

All engines are running at the same viscosity and intended to operate on heavy fuel oil at all times, full power, manoeuvring and in port.

Operation on diesel oil should only be done during abnormal conditions and during major overhaul of the fuel oil system.

The system is capable of preparing heavy fuel oil with a viscosity of 700 cat. at 50°C and arranged as a pressurised fuel oil system in order to prevent foaming and high-pressure fuel oil pump cavitations.

It is possible to lift each fuel pump of the ME separately with a lifting gear.

### Description

Two supply pumps take suction from the heavy fuel oil service tanks or from the diesel oil service tank through an adjustable 3-way mixing valve. The supply line from each service tank is equipped with none-return valves in order to prevent confluence.

The supply pumps discharge to the venting tank at a pressure of approx. 4 bar(g). The total amount of fuel oil supplied to the venting tank, is measured by a flow meter (totalise) equipped with a by-pass valve.

The capacity of each supply pump exceeds the max. consumption of the main engines and the diesel engines.

The venting tank can be drained to the spill oil tank through a drain valve.

Two fuel oil circulation pumps take suction from the venting tank and discharge to the fuel oil circulating line, supplying fuel oil to the injection system of the main engines and of the diesel generators. The circulating line is equipped with two steam heated fuel oil heaters, one back flush fuel oil filter, one bypass filter and one viscosity controller. The capacity of each heater is sufficient for the max consumption for the main engines and the diesel engines.

There is a facility to run the diesel generators on marine diesel oil with the main engine on heavy fuel oil.

The capacity of each circulating pump exceeds the max consumption of the main engines and the diesel engines.

Excess fuel is normally returned to the venting tank. Provision is also made to return the fuel oil to the service tanks through a 3-way changeover valve.

An adjustable (5-10 barg) back-pressure valve maintains a constant pressure in the circulation line.

A fuel circulation circuit is installed to allow pier-to-pier operation on HFO. The circulation oil heats the injection valve and fuel oil distributor even when the ME is stopped.



The fuel oil line to the main engines is equipped with an emergency shut off valve for remote control (outside engine room).

Steam for heating of the venting tank and all fuel oil lines (steam tracing) is supplied through an adjustable (0-10 barg) steam reduction valve. Steam for fuel oil heaters and steam tracing can be shut off by stop valves.

### **Fuel oil viscosity control**

The viscosity controller positions the steam valve of the fuel oil heater directly (single PID loop), or indirectly by adjusting the set point of a separate slave controller (cascade control).

The feedback signal to the slave controller is the fuel oil outlet temperature of the fuel oil heaters (High Selected).

At low load, it may prove to be necessary to stabilise the controller by reducing the steam supply to the fuel oil heaters.

This controller can be configured in cascade. A controller connected this way will be more stable and less sensitive to supply steam pressure than with a directly connected PID control.

### **Operation procedure**

#### **1. Preparation and starting at diesel oil**

##### Supply system

- 1.1 Set 3-way valve into diesel oil position (100% for pure diesel oil).
- 1.2 Ensure sufficient level in diesel oil service tank and drain the tank.
- 1.3 Line up system from diesel oil service tank to venting tank – by pass valve for fuel oil flow meter normally to be closed.

- 1.4 Close venting tank drain valve.

##### Circulation system

- 2.1 Open valves to one of the fuel oil heaters and the back flush filter.
- 2.2 Check that the main engine fuel oil emergency shut off valve is open.
- 2.3 Open fuel oil shut off valves for both main engines and the supply valve for the diesel generators.
- 2.4 Return line valve pressure controller must be set to 7-8 barg.
- 2.5 Check that the 3-way valve in the return line is set to return to venting tank.
- 2.6 Set fuel oil viscosity controller into Manual.
- 2.7 Check that the valves for steam supply to fuel oil heaters and steam tracing are closed.
- 2.8 Start one of the supply pumps manually and check the discharge pressure, temperature and flow.
- 2.9 When the venting tank is filled up, start one fuel oil booster pump manually and check discharge pressure, temperature and flow.
- 2.10 Select auto stand by for supply pumps and for booster pumps at the Power Chief – Pump Control panel.

##### **NOTE 1:**

If steam system is not shut off effectively by closing the stop and control valves of the steam system, there is a risk of heating the diesel oil. Too high temperature of the diesel oil may cause poor lubrication of high-pressure pump's plunger and of fuel oil nozzle needle valve due to low viscosity. This again may cause piston or needle valve to seize.

**NOTE 2:**

If there is no fuel oil consumption from the fuel oil supply system the supply pumps must be stopped in order to avoid damage of the pump due to high temperature.

The supply pump will stop when the casing temperature is raised to 135°C. and can be started again when the temperature is lowered again.

It can be necessary to stop the pump and only circulate the oil through the heater with the booster pump, or to change the return select valve to return to service oil tank so the flow is maintained to cool down the supply pumps casing temperature. Normally when the diesel generators are supplied from the fuel oil system, there will be no problems.

**3. Changing from diesel oil to heavy fuel oil.**

The main engine load must be max. 30% and the engine well heated.

- 3.1 HFO purifier to be in operation
- 3.2 Ensure sufficient level in the HFO service tank and proper temperature in order to get a suitable oil viscosity.
- 3.3 Drain the tank
- 3.4 Line up the system from HFO service tank to 3-way mixing valve.
- 3.5 Open steam valves to selected FO heater.
- 3.6 Open steam valve for steam tracing.
- 3.7 Set steam line pressure controller to desired setting. (5-8 barg) and check steam pressure.
- 3.8 Set viscosity controller into manual and set point at 0%, then the steam valve in the supply line is closed to the heaters.

- 3.9 Slowly admit steam to heater raising temperature 1-2°C in a minute by increasing the manual set point.
- 3.10 Maintain temperature until pumps, fuel valves etc. are heated to correspond with the oil temperature.
- 3.11 Ensure oil in the fuel oil service tank is heated to about 75-95°C and change over to fuel operating with mixing valve V00077.
- 3.12 Slowly increase oil temperature to normal temperature.

Quicker change-over can be obtained with return to service tank open. This, however, may cause needle valves to seize in fuel injectors.

**4. Changing from heavy fuel to diesel oil**

Reduce the main engine load to 30% of normal.

- 4.1 Slowly reduce the temperature on HFO by adjusting the viscosity controller manually, maximum reducing 10°C in 5 minutes.
- 4.2 With mixing valve V0077 change to diesel oil when temperature has dropped to about 5°C above the temperature in the diesel oil service tank.
- 4.3 After change-over there may be a considerable drop in temperature, the transition must be moderated by supplying a little steam to the pre-heater.

Too quick temperature drop can cause fuel oil high-pressure pump's plungers to seize due to plunger-liner contraction / reduced lubrication.



With main engine running, best result in viscosity control is obtained with controllers in CASCADE, VISCOSITY CONTROLLER in AUTO.

**Note:** If for some reason venting tank must be drained, the three-way valve can return the fuel oil to the settling tank(s).

The diesel engines are usually stopped and started with HFO in fuel lines. Diesel oil is used if the engine is going to be stopped for a prolonged period (dry-docking) or when conducting major overhauls to fuel system. If ambient temperature is extremely low, or if steam system is out of commission, change to diesel oil before stopping or empty lines by changing to diesel oil and re-circulating oil back to HFO service tank.

### **Fuel oil gassing**

If the fuel oil temperature after the fuel oil heaters rises higher than the fuels boiling temperature "gassing" of the oil is simulated. Fuel oil gassing causes that:

- the running of the main engine is disturbed.
- the signal from the viscosity meter becomes very noisy.
- Normally HFO gassing develops above 135°C and for DO above 80°C adjustable.

### **Fuel oil quality**

Fuel oil quality (heating value, density, and viscosity) can be set from variable page.

<This page is intentionally left blank>

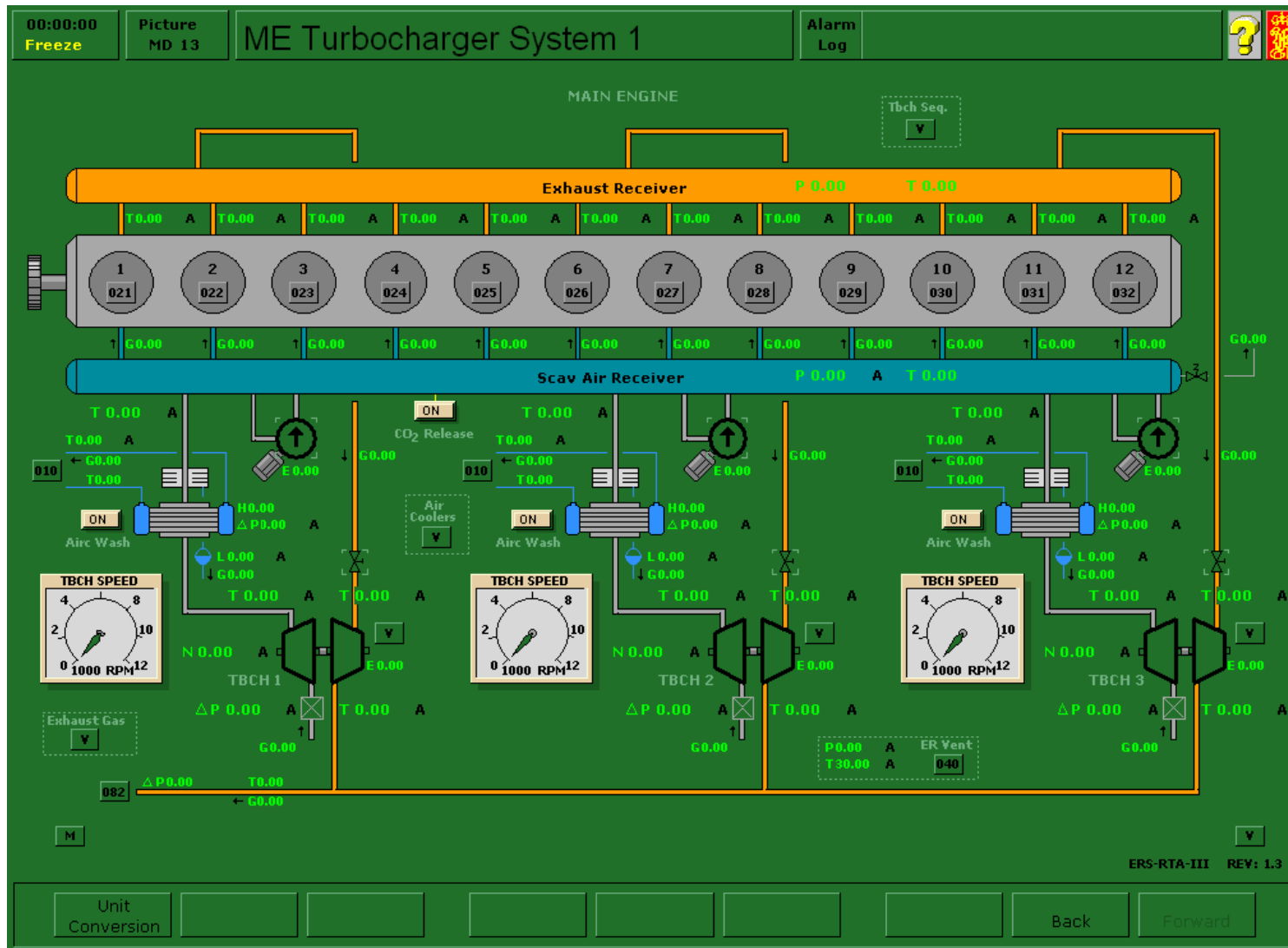



### 3.7 ME Turbocharger System

#### General

The main engine is supercharged by three constant pressure turbochargers. The turbo-charged air is cooled in a fresh water-cooled air cooler before entering the main engine.

The air cooler must be kept clean to enable it to provide a sufficient amount of cool air to the engine. Hot air will lead to high exhaust temperatures, greater heat losses and increased specific fuel oil consumption.

After the air leaves the air coolers, it enters the demister units that are fitted to reduce the water content of the air. Water is drained off the demister units via the water trap.

Dirty turbo-charger air filters throttle the scavenging airflow and will result in reduced engine performance.

The exhaust gas from the main engine cylinders enters the common exhaust gas receiver. From the receiver the exhaust gas flows through the turbochargers and then to the exhaust gas boiler.

The exhaust boiler must be kept clean. High back pressure reduces scavenging air flow and engine efficiency, especially at high power.

#### Operation procedure

1. Line up the system by opening the fresh water cooling throttle valves to air coolers 1, 2 and 3.

2. Ensure the scavenge air receiver drains are closed on individual cylinders.
3. Check that the Aux. Blowers 1, 2 and 3 are running. These are operated from MD102. Preset values for start/stop of aux. blower are respectively 0.25 bar and 0.4 bar (variable page 1311).

A blow down valve to drain the contents of the scavenge receiver is provided on each cylinder. This valve should be opened twice daily.

#### Cleaning

##### Air coolers:

The air coolers are equipped with a washing arrangement to clean the coolers on the air side. The dirty water will be led out through the water drain. Before starting the washing check that the drain is working.

#### Turbocharger

##### Air side:

- The wash-cleaning of the turbocharger air compressor should be carried out every 25-75 hours depending on increase of exhaust temperature.
- The cleaning should be carried out at full service output.
- Keep the “wash-button” press for approximately 8-10 sec.



**Exhaust side:**

- The wash cleaning of the turbine should be carried out every 50-500 hours depending on the increase of exhaust temperature during constant operating condition.
- The cleaning should be carried out at **reduced ME output** (about 50-55% on the control level) with an exhaust temperature before the turbine approximately 300°C.
- Keep the ME at the reduced power for at least 5 minutes before water is applied to turbine.
- Wash for at least 5 minutes.
- The ME should run at reduced load for at least 5 minutes after wash-cleaning to dry the turbine.
- Check the vibration level for the turbochargers before increasing the ME speed.

**Fire in scavenge air box**

**Warnings of fire:**

- An increase in the exhaust temperature of the affected cylinder,
- The turbocharger may surge,
- Smoke from the turbocharger air inlet filters when the surging occurs,
- The scavenge air box being noticeably hotter.

**Measures to be taken:**

Owing to the possible risk of a crankcase explosion, do not stand near the relief valves – flames can suddenly be violently emitted.

1. Reduce speed/pitch after permission from the bridge to slow and stop the engine.

2. When the engine stop order is received, stop the engine and switch-off the auxiliary blowers.
3. Stop the fuel oil supply.
4. Stop the lub. oil supply.
5. Put the scavenge air box fire CO<sub>2</sub> release equipment into function.
6. Before opening to the engine make fire hoses ready for fire-fighting.

**Do not open the scavenge air box or crankcase before the site of the fire has cooled down to under 100°C. When opening, keep clear of possible fresh spurts of flame.**

**Note:** Differential pressure across cooler and air inlet filter should be checked regularly.





<This page is intentionally left blank>

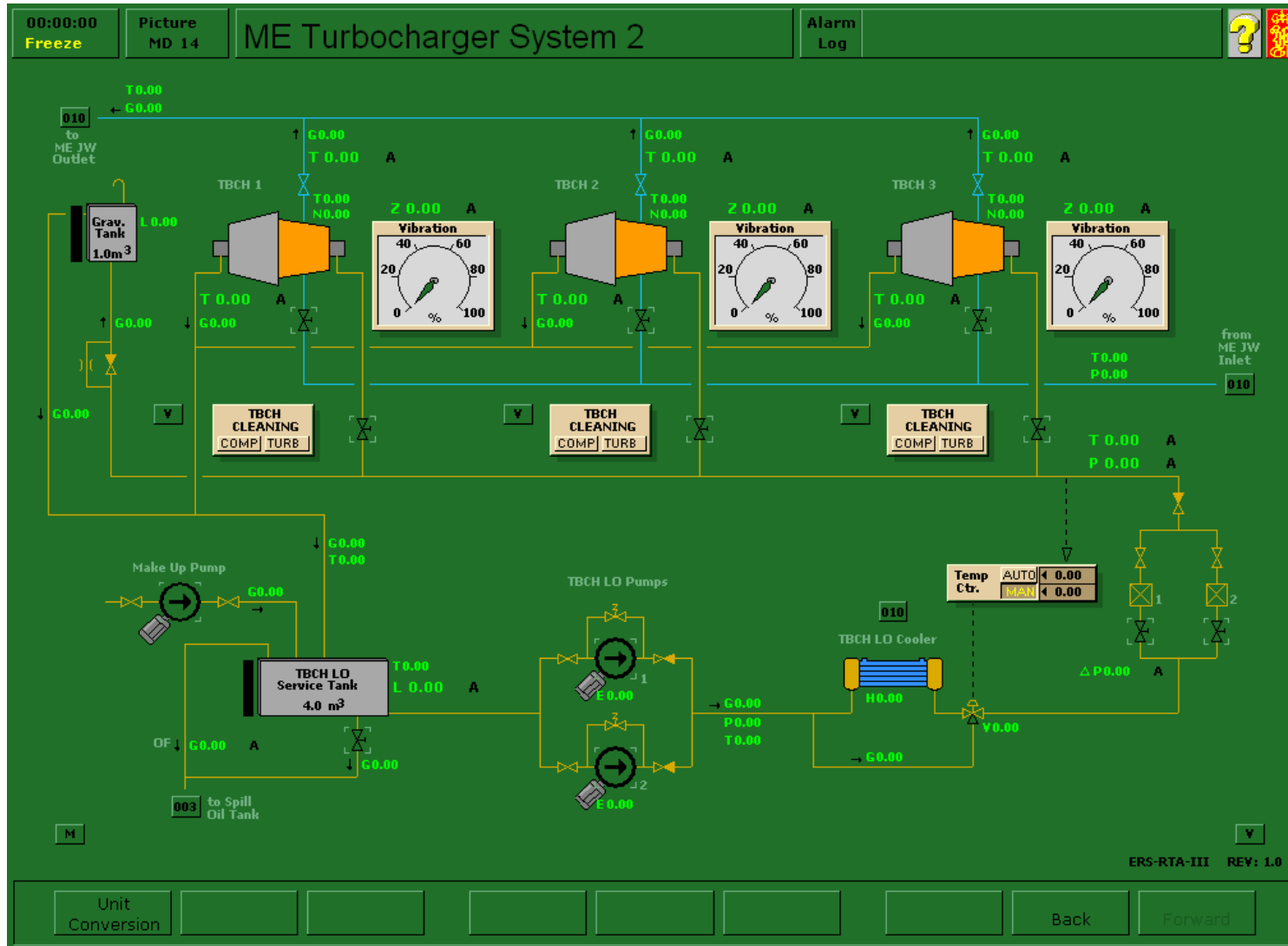



The lubrication oil to the TBCH bearings is pumped from a service tank.

The LO pumps are protected by a pressure relief valve which opens for pressure over a preset value.

A make-up pump enters new oil with flow directly to the service tank.

The lubrication oil is cooled by a LT freshwater cooled LO cooler and is then passing a double filter before it enters the main engine.

The LO temperature is controlled by a PI controller, which regulates a by-pass valve for the LO cooler.

The LO filters must be cleaned regularly to avoid pressure/flow reduction.

The freshwater cooling to the TBCH is coming from the ME LTFW cooling system.

**Operation:**

1. Ensure that the turbocharger LO tank is filled to the correct level and replenish if necessary.
2. Check that the low temperature central cooling system is operating and that cooling water is circulating through the turbocharger LO cooler.

3. Check that the valves are in the right position.

4. Check that the duplex filter is clean.

5. Start the turbocharger LO pump and check that oil is flowing to the three turbochargers and returning from the turbocharger bearings.

6. Select the second LO pumps as the standby pump.

7. The turbocharger LO system is now operational and the turbochargers may be operated.

**Note:**

The turbocharger LO must be tested frequently in order to determine whether or not it is fit for further service. Sample should be taken from the circulating oil and not directly from the tank.

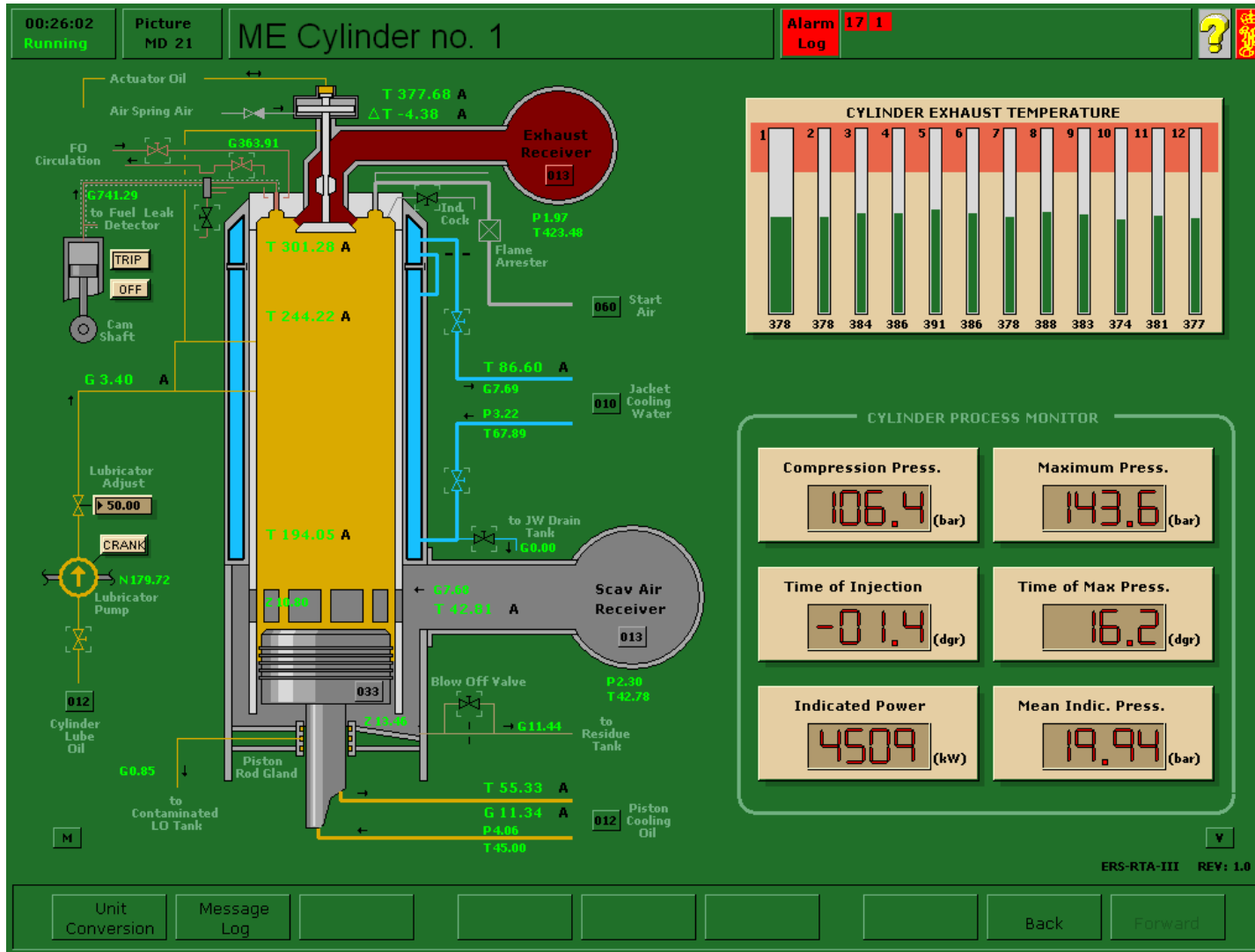



## 3.8 ME Cylinder

### General

The twelve screens are indications of the various parameters of the individual cylinders. The following indications are present:

- Cylinder exhaust temperature and deviation from the average exhaust temperature.
- Exhaust receiver pressure and temperature gauges.
- Cylinder exhaust temperature chart illustrating each cylinder.
- Scavenge receiver pressure and temperature gauges.
- Piston oil cooling temperature and flow indications.
- Cylinder cooling water temperature and flow.
- Cylinder process readings for compression pressure, maximum pressure, injection timing, timing of max pressure, indicated power and MIP.

The contents of the scavenge space around each cylinder are led to a residue tank and are constantly blown via an orifice. A blow down valve is also provided on each cylinder. This valve should be opened twice daily.

The cylinder lubrication oil quantity can be adjusted to suit the running conditions and manufacturer's recommendations. Before starting the engine the cylinder can be individually pre-lubricated by use of the crank, or activation of pre/post lubrication from the AutoChief.

Fuel is constantly circulated around the injectors to allow manoeuvring on HVFO. The injectors automatically close the recirculation when the injection pressure rises. If the fuel oil system has to be vented because air in the high pressure pipes due to repair work, this is carried out by starting the booster pump, adjusting the FO pressure control valve to approx. 14 bar and open the fuel distributor priming valve until no air is longer present.

The fuel pump has a trip indication activated by leakage in the high pressure lines and may be manually lifted to shut off the fuel to individual cylinders should it be required (scavenge fire, burst fuel pipe etc). Lifting of the pump should only be carried out at low speed.

Indicator cocks are provided at each cylinder.

The cooling water may be isolated and drained for each cylinder for maintenance purposes.

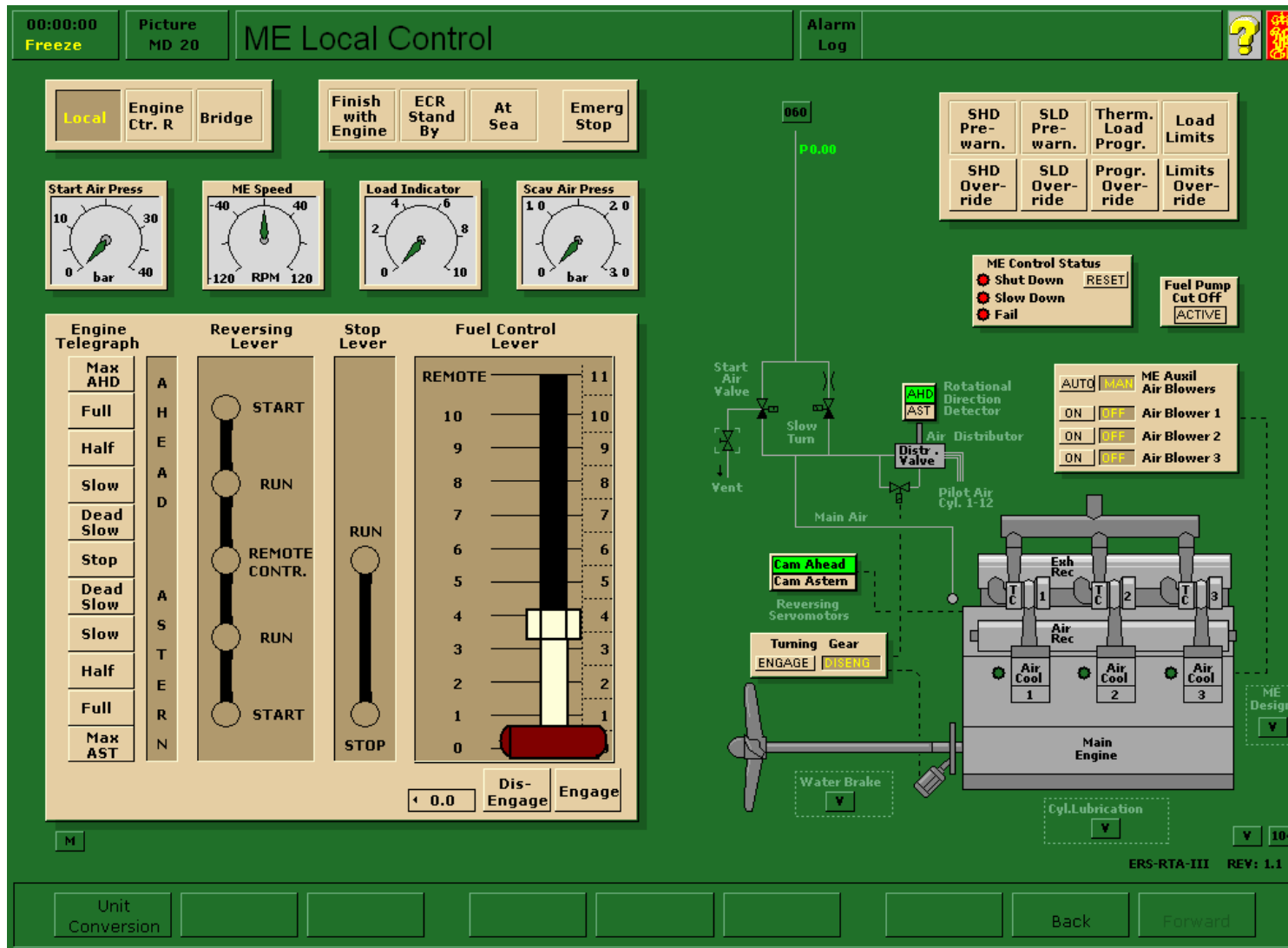



### 3.9 ME Local Control

#### General

Local control of the main engine is provided to enable operation and control of the main engine should a defect or malfunction of the main control or manoeuvring system occur.

In Local control the automatic thermal load programme, main governor functions, and slow down protection is overridden.

The following functions are available on the local panel:

- Indication of ME revolution and start air pressure
- Indication of safety functions
- Indication of punctured fuel pumps (activated at stop)
- Indication of responsibility
- Indication of cam position and engine rotation direction
- Indication of fuel control lever
- Turning gear engage/disengage
- Emergency stop
- SLD, SHD, Thermal Load program and Load limitation
- Telegraph handle
- Auxiliary blower control

#### Start/stop procedure of the ME at the Local Panel:

##### Note!

Before starting engine after prolonged stop, always “blow through” engine with starting air with indicator cocks open. When stoppage exceeds 30 minutes while manoeuvring, it is recommended to perform a slow turning of engine before starting attempt is commenced.

1. Checklist for departure must be completed.
2. The local control is selected at either the Engine Control Room or Bridge. This will cause the local station indicator to flash.
3. The command is accepted at the local control panel. This will cause the local station indicator to remain lit.
4. The fuel control lever should be engaged.
5. The Emergency telegraph should be observed, and any command from the Bridge acknowledged.
6. Put the stop lever in run position.
7. The fuel lever should be moved to start position (40 % of nominal speed).
8. If reversing set the reversing lever in ahead or astern direction and when reversing is OK, set the lever in start position.
9. When the engine is running with a satisfactory rev/min set the reversing lever in run position.
10. Stop the ME has to be done by the stop lever.
11. Start again has to be done with the reversing lever moving from run to start. When the engine is running set the lever back to run position.

##### Note:

- When manoeuvring from the bridge or ECR:
- The reversing lever must be in remote control (middle position).
- Stop lever in run position.
- The fuel control lever disengaged with the lever in position “11”.
- Light in ECR or bridge lamp.

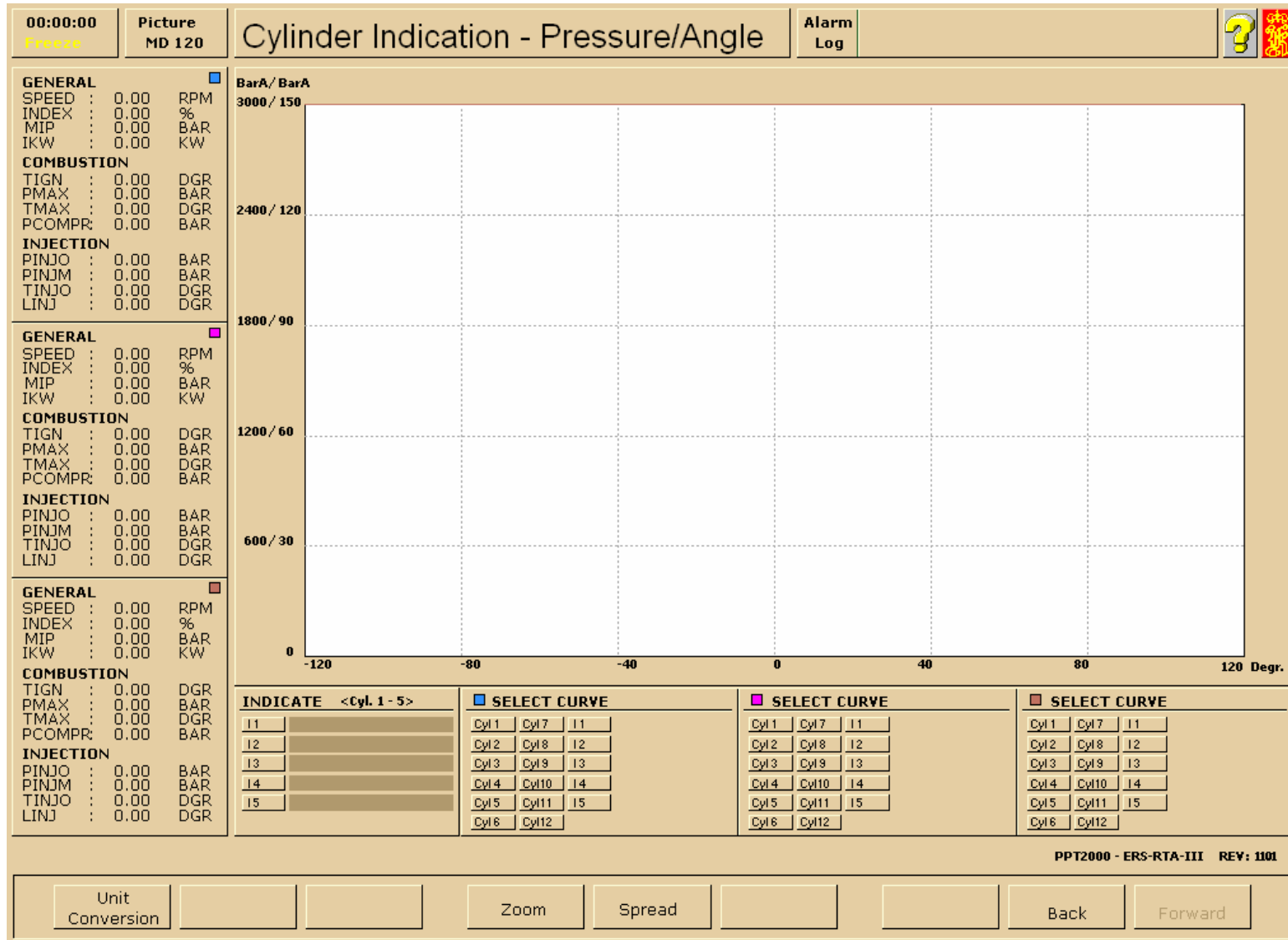





## 3.10 Cylinder indications

### 3.10.1 Press/Angle

#### General

The cylinder indicator is used as an investigative system to enable regular monitoring of the engine cylinders to be undertaken. Faults within the combustion system can be located.

There are two different displays that can be selected to indicate the cylinder pressure conditions, pressure/volume (also called a power card, or in-phase diagram). Each diagram can be used to illustrate differing combustion traits.

The pressure/angle diagram would be used for:

- Display the compression pressure curve, for comparisons with the other cylinders, to indicate cylinder sealing efficiency.
- Display the approximate timing of the fuel ignition.
- Display the fuel pressure trace (using the alternate pressure measurements of 0-3000bar).

To enable the cylinder indicator to measure the combustion pressure, the following actions are required:

1. Select one of the field button (I1 to I5) in the INDICATE column.
2. Type in your identifying comments in the INDICATE field to aid future fault identification.

3. Select the same field button (I1 to I5) in the SELECT CURVE column. Either the blue, magenta, or brown curve can be selected.
4. Select the cylinder 1 to 12 that you wish to be measured.

To measure and compare the same cylinder after a period of operation, or when a malfunction is present. Using cylinder 2 as an example:

1. Carry out the tasks 1 to 3 above using the blue curve column and I2.
2. Select cylinder 2 to measure.
3. Select another field button (not chosen in point 1 such as I3) in the Indicate column.
4. Type in your identifying comments in the Indicate field.
5. Select I3 in Select Curve of the magenta column.
6. Select cylinder 2 to measure the combustion parameters of cylinder 2 again.

The following parameters are displayed in the numeric data display, at the instant when the cylinder indicator is taken, once a cylinder is selected together with the two indicate (I) buttons:

- |         |                                     |
|---------|-------------------------------------|
| Speed - | This is the engine speed (N).       |
| Index - | This is a measure of the fuel index |



- MIP - This is the Mean Indicated Pressure (MIP) measured in bar. This pressure is the equivalent pressure that acts on the piston throughout its vertical power stroke.
- IkW - This is the Indicated Power of the cylinder, and is calculated from
- $$MIP \times \text{volume of working piston} \times N$$
- T<sub>IGN</sub> - This is the timing of the ignition. The time between the T<sub>INJO</sub> and T<sub>IGN</sub> indicates the ignition delay present for that cycle. Increasing ignition delays will cause increased P<sub>MAX</sub> and large delta pressure/angle ( $\delta P/\delta \alpha$ )
- P<sub>MAX</sub> - This is the maximum pressure present during the working cycle. This will be affected by the quantity and timing of the fuel admission.
- T<sub>MAX</sub> - This is the position of the timing of the maximum pressure during the working cycle.
- P<sub>COMPR</sub> - This is the pressure due to compression alone after the compression stroke. It provides valuable information to the efficiency of the compression stroke, and the sealing efficiency of the piston rings, liner, and cylinder cover valves.
- P<sub>INJO</sub> - This is the fuel pressure when the fuel injector opens. It provides useful information that the fuel injector is correctly adjusted.
- P<sub>INJM</sub> - This is the maximum fuel pressure generated by the fuel pump. This indicates the internal sealing properties of the pump, and whether internal wear is present.
- T<sub>INJO</sub> - This is the timing of the fuel injection. The fuel pump timing will change when the VIT operation is selected on MD110, but it should be similar for all fuel pumps.
- L<sub>INJ</sub> - This is the length of the fuel injection period, and is dependent on the setting of the fuel control lever.

On the lower part of the diagram, the button Zoom can be used to zoom the diagram in horizontal direction to 300%. The button Spread is used to move overlaying curves apart vertically.



<This page is intentionally left blank>

00:00:00  
Freeze

Picture  
MD 121

## Cylinder Indication - Pressure/Volume

Alarm  
Log

**GENERAL**

SPEED : 0.00 RPM  
 INDEX : 0.00 %  
 MIP : 0.00 BAR  
 IKW : 0.00 KW

**COMBUSTION**

TIGN : 0.00 DGR  
 PMAX : 0.00 BAR  
 TMAX : 0.00 DGR  
 PCOMPR: 0.00 BAR

**INJECTION**

PINJO : 0.00 BAR  
 PINJM : 0.00 BAR  
 TINJO : 0.00 DGR  
 LINJ : 0.00 DGR

**GENERAL**

SPEED : 0.00 RPM  
 INDEX : 0.00 %  
 MIP : 0.00 BAR  
 IKW : 0.00 KW

**COMBUSTION**

TIGN : 0.00 DGR  
 PMAX : 0.00 BAR  
 TMAX : 0.00 DGR  
 PCOMPR: 0.00 BAR

**INJECTION**

PINJO : 0.00 BAR  
 PINJM : 0.00 BAR  
 TINJO : 0.00 DGR  
 LINJ : 0.00 DGR

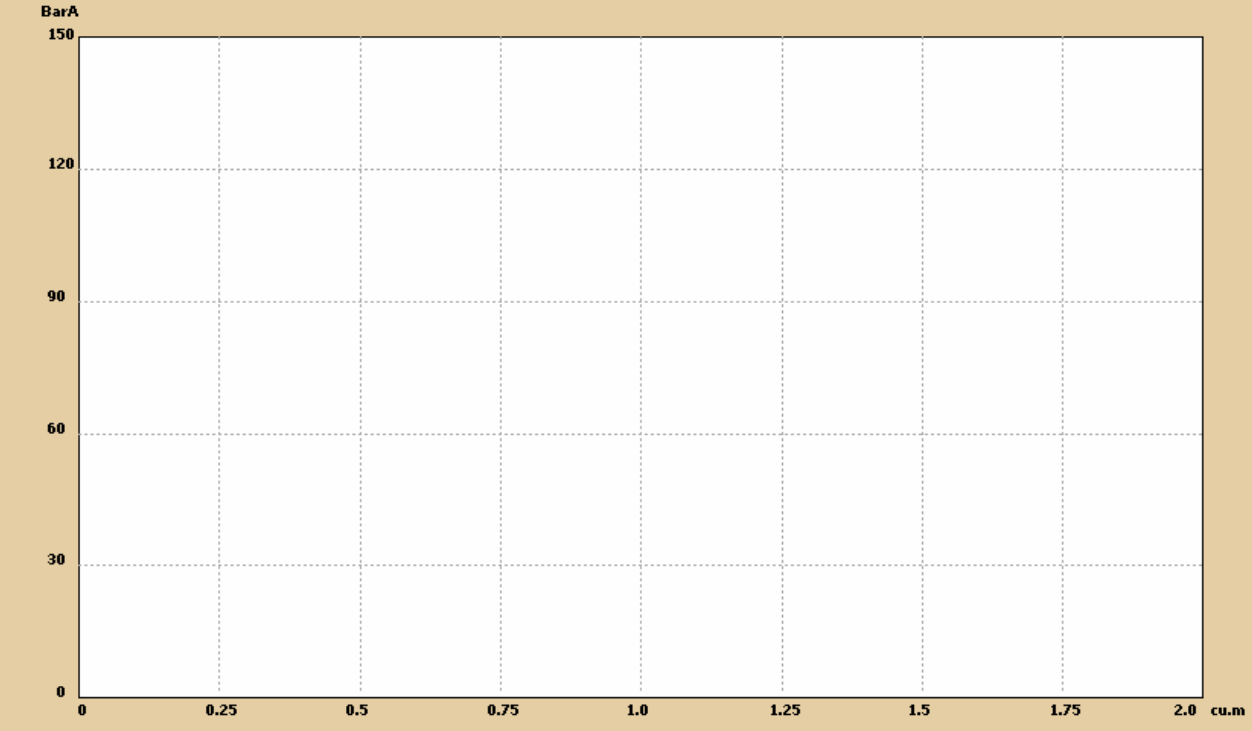

**GENERAL**

SPEED : 0.00 RPM  
 INDEX : 0.00 %  
 MIP : 0.00 BAR  
 IKW : 0.00 KW

**COMBUSTION**

TIGN : 0.00 DGR  
 PMAX : 0.00 BAR  
 TMAX : 0.00 DGR  
 PCOMPR: 0.00 BAR

**INJECTION**

PINJO : 0.00 BAR  
 PINJM : 0.00 BAR  
 TINJO : 0.00 DGR  
 LINJ : 0.00 DGR

**INDICATE (Cyl. 1 - 5)**

11	
12	
13	
14	
15	

**SELECT CURVE**

Cyl 1	Cyl 7	11
Cyl 2	Cyl 8	12
Cyl 3	Cyl 9	13
Cyl 4	Cyl 10	14
Cyl 5	Cyl 11	15
Cyl 6	Cyl 12	

**SELECT CURVE**

Cyl 1	Cyl 7	11
Cyl 2	Cyl 8	12
Cyl 3	Cyl 9	13
Cyl 4	Cyl 10	14
Cyl 5	Cyl 11	15
Cyl 6	Cyl 12	

**SELECT CURVE**

Cyl 1	Cyl 7	11
Cyl 2	Cyl 8	12
Cyl 3	Cyl 9	13
Cyl 4	Cyl 10	14
Cyl 5	Cyl 11	15
Cyl 6	Cyl 12	

PPT2000 - ERS-RTA-III REV: 1101

Unit  
Conversion

Back

Forward



### 3.10.2 Press/Volume

#### General

The pressure/volume diagram displays the classical p~V diagram used in thermodynamic calculations to measure the power produced within a cylinder.

The x –axis displays the swept volume of the piston.

The pressure/volume diagram would be used for:

- Display the classical power diagram, where the area within the diagram equates to the power developed by that power stroke.
- Display the maximum pressure.
- Display the expansion curve and thus indicating whether there is slow burning fuel or afterburning of the cylinder combustion products present.

To enable the pressure indicator to measure the same procedure is required as for any of the cylinder indication screens. Once one screen has been activated, then ALL screens will indicate the same numerical information on the left side of the screen display, although the graphical information will change.

To enable the cylinder indicator to measure the combustion pressure, the following actions are required:

1. Select one of the field buttons (I1 to I5) in the INDICATE column.
2. Type in your identifying comments in the INDICATE field to aid future fault identification.
3. Select the same field button (I1 to I5) in the SELECT CURVE column. Either the blue, magenta, or brown curve can be selected.
4. Select the cylinder 1 to 12 that you wish to be measured.

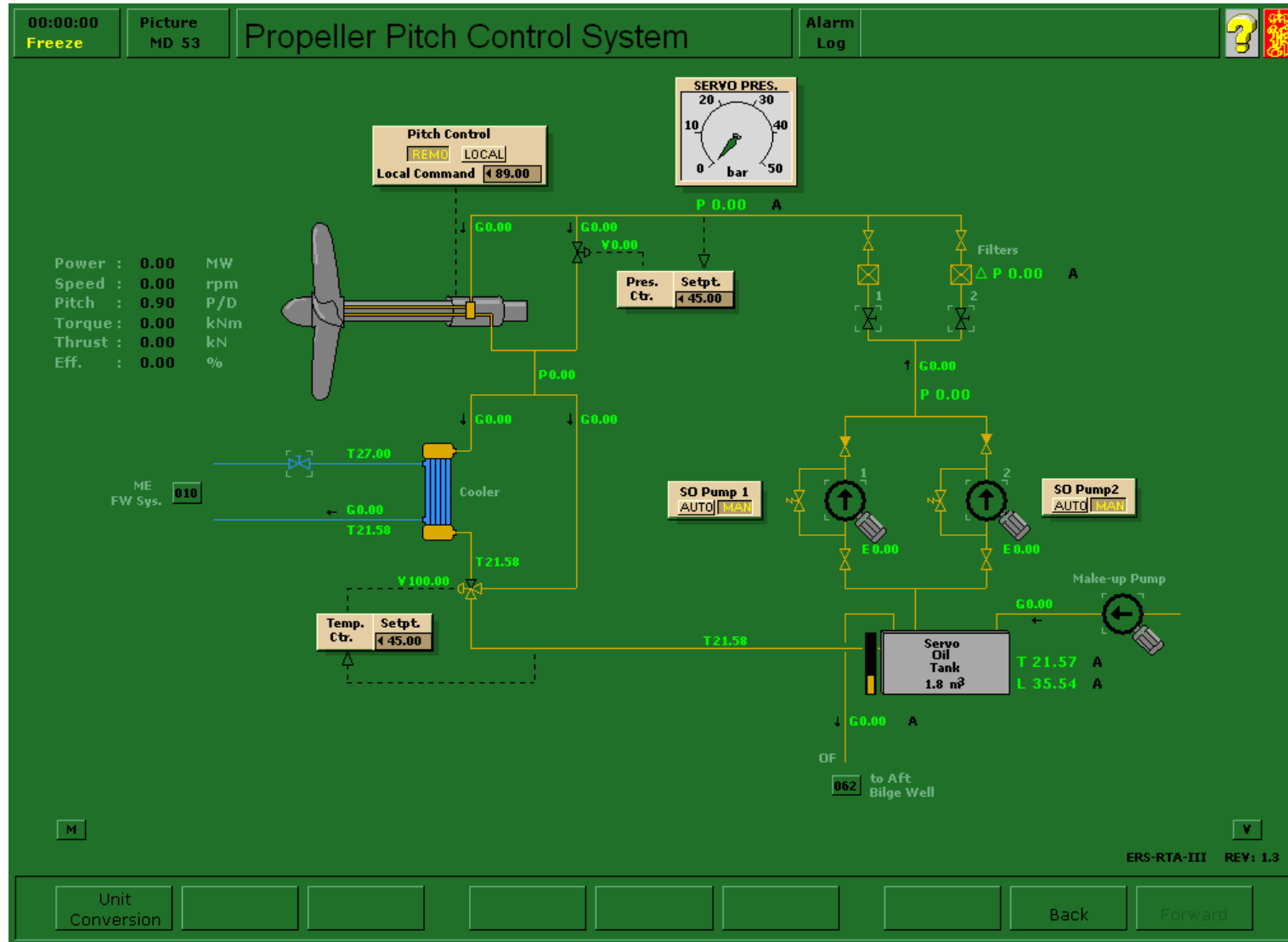



## 4 PROPELLER AND STEERING GEAR SYSTEMS

### 4.1 Propeller Servo Oil System

#### General

The propeller pitch servo is operated by high-pressure hydraulic oil supplied by two electrically driven pumps. Usually only one pump is used with the other in stand-by mode.

The pitch control is dependent on hydraulic pressure. At low oil pressure, the maximum rate of pitch change is reduced correspondingly. If the oil is cold, the pitch servo acts more slowly.

#### Description

High pressure oil is delivered to the pitch servo. The pressure is controlled by bypassing oil through the pressure control valve, using a P-controller. Default pressure is 45 bar.

The return oil is cooled by LT fresh water and is controlled to be 45°C, again using a P-controller. The oil drains to the servo oil tank.

When pitch control is set to Local control, the pitch command is set in the numeric window in % of pitch range.

#### Operation procedure

##### 1. Starting procedure:

- 1.1 Main engine sea water system and LT fresh water system must be in service.
- 1.2 Open fresh water inlet valve to servo lubricating oil cooler.
- 1.3 Open selected filter inlet valve.
- 1.4 Check level in Servo oil tank.
- 1.5 Select Local or Remote pitch control.
- 1.6 Start the lubricating oil pump locally or from the PowerChief Pump Control panel.
- 1.7 Put the lubricating oil pumps into AUTO mode from the Pump and Compressor Panel.

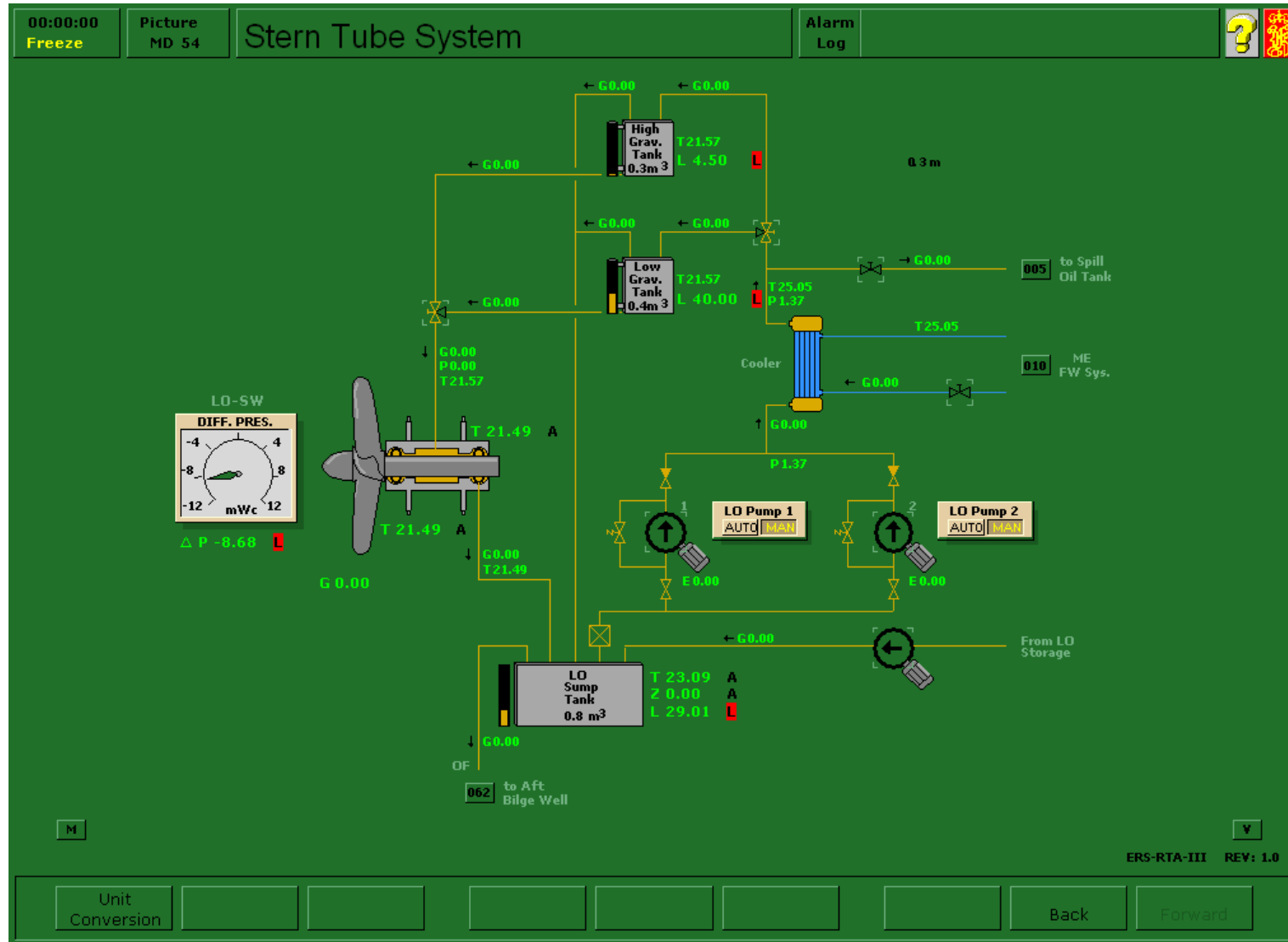





## 4.2 Stern Tube System

### General

The stern tube bearings are lubricated by two separate gravity LO tanks, one high and one low gravity. These are selectable and should be chosen according to vessel draft.

### Description

The oil is pumped from the stern tube sump tank to the selected gravity tank, from where it flows to the stern tube bearings by gravity.

The gravity tank is automatically filled by one of the lubricating oil pumps and surplus oil is continuously drained to the sump tank through an overflow pipe.

The oil is cooled as it is pumped to the gravity tank. The heat exchanger is LT fresh water cooled.

If the running pump fails to maintain the level in the gravity tank the stand by pump will start at low level in the gravity tank provided that the pump is in Auto mode. The low-level limit can be adjusted from the variable page.

Stopping of pumps has to be carried out manually.

Refilling of the lubricating oil sump tank is carried out by starting the make-up pump.

The oil can be transferred to the spill oil tank in case of contamination.

The stern tube has a fwd seal oil system that can be topped up from the gravity feed line.

### Operation procedure

- 1.1 Ensure cooling water to Stern Tube cooler.
- 1.2 Refill lubricating oil sump tank if necessary.
- 1.3 Select required gravity tank using 3-way valve in filling line.
- 1.4 Select correct gravity feed to stern tube.
- 1.5 Start the lubricating oil pump in manual.
- 1.6 When one pump is started, set the other pump in Auto.
- 1.7 If the running pump is unable to maintain the level in the gravity tank, the stand-by pump starts automatically.
- 1.8 Check level of oil in sealing tank, fill from make-up valve. Drain water if required.
- 1.9 Stop of pumps to be carried out manually.

### Daily:

Control the contamination (water) in the LO sump tank.

### Weekly:

Take a LO sample and check the water content.

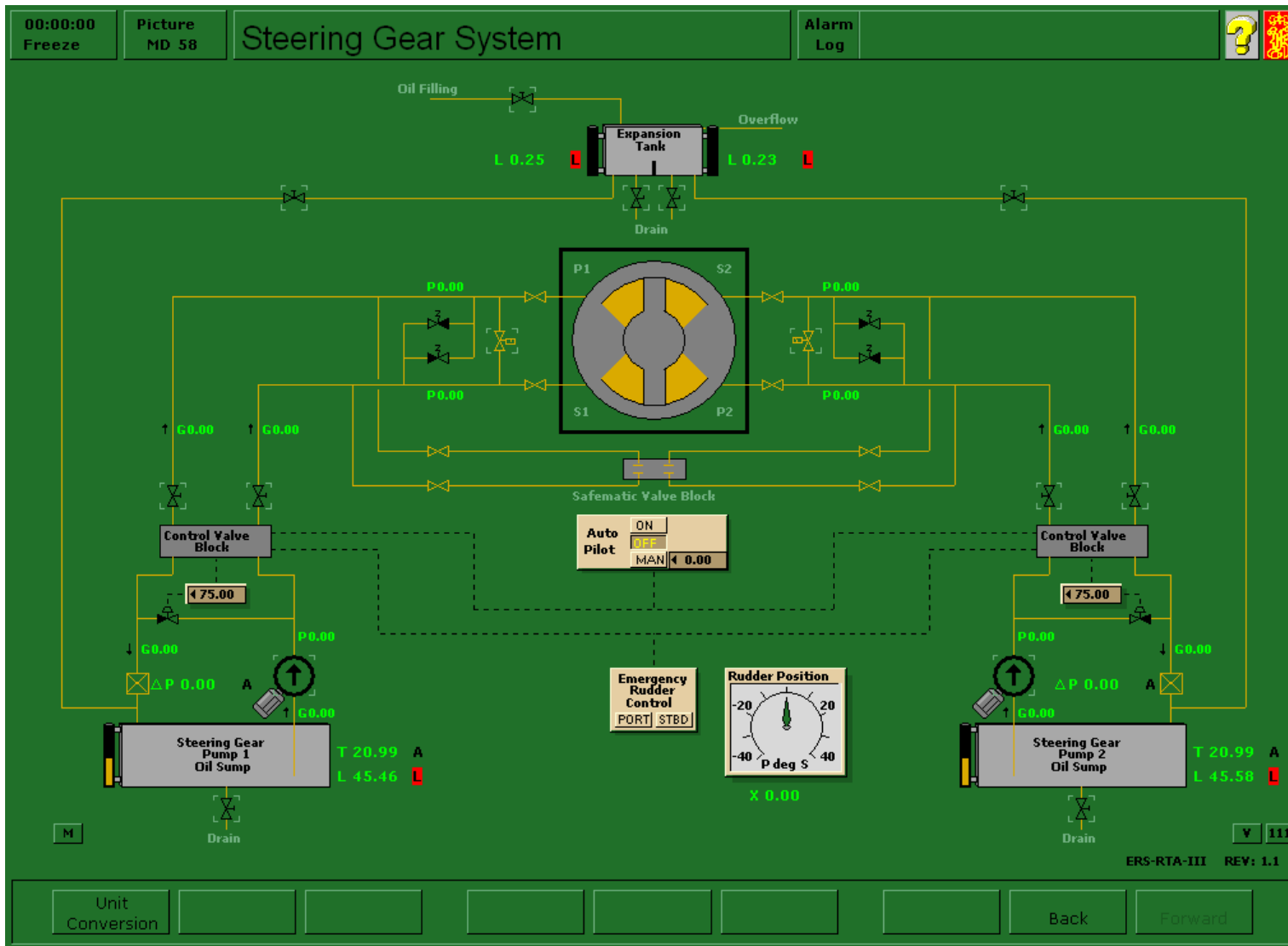

## 4.3 Steering Gear System

### General

#### The steering gear system comprises:

- one hydraulic steering gear of the rotary vane type,
- two identical hydraulic systems. Each system includes:
  - one steering gear pump Unit
  - one control valve block assembly
  - necessary measuring, indication and alarm facilities for pressure, temperature, level and flow
  - necessary control and safety equipment
- one expansion tank common to both hydraulic systems
- emergency steering control equipment
- rudder angle indication

The steering gear is able to change the rudder position from 35 deg. to -30 within 48 sec. with one pump and 24 sec. with two pumps, independent of ship speed. The increased demand of thrust on the rudder at higher ship speed is taken care of by increased pump pressure.

The steering gear system is of the “IMO model” with the functionality required according to Classification Societies for gas carriers and oil tankers above 100000 tons.

#### Hydraulic system description

The steering gear itself is operated by two open type, low pressure hydraulic systems.

Each hydraulic system is supplied from a steering gear pump Unit (Power Pack) comprising:

- oil tank with a bottom drain valve
- steering gear pump of the fixed displacement type
- return line oil filter
- level indication
- equipment for monitoring of temperature, pressure and level

Additionally each system is equipped with:

- One adjustable system pressure-relief control valve controlling the maximum discharge pressure from the steering gear pump. Default setting is 75 bar. Above this pressure, the hydraulic oil will be by-passed back to the oil suction tank.
- one shock-relief control valve block with two adjustable relief control valves protecting the steering gear and the hydraulic system against pressure shocks when braking the rudder movement
- stop valves for manual isolating of the system
- one manual operated stop valve for by-pass of the pressure-relief shock valves.

The oil tank is connected to the bottom of the expansion tank, common to both hydraulic systems and normally the oil tank is full (100% level).



Each system is provided with the following alarms and safety functions:

- **LOW LEVEL - STEERING GEAR UNIT TANK**
- **LOW LEVEL STOP - STEERING GEAR PUMP**
- **OIL FILTER HIGH DIFFERENTIAL PRESSURE**
- **HIGH OIL TEMPERATURE**

Steering gear pump no 1 and the belonging controls are supplied from bus bar 1.

Steering gear pump no 2 and the belonging controls are supplied from Emergency bus bar.

Emergency steering may be carried out, in case of system communication failure with the bridge.

### **Control system description**

The steering gear control system is of the on-off type (3-point control). The electrical controlled directional-control valve integrated in each of the control valve blocks controls the rudder angle. The control valve block also includes over centre- and flow control valves, necessary for mechanical and hydraulic safety and control.

#### **Normal control** (Follow up control)

The directional-control valve receives its control signals from the automatic rudder control system, having its set point either from the auto pilot or from the manual rudder control located both locally and at the bridge steering console.

At deviations between the actual rudder position and the desired rudder position, a port or starboard signal is given to the electrical directional-control valve. The control valve changes its position and hydraulic oil is lead in an out of the respective chambers at the

steering gear, shifting the rudder angle towards the desired position as long as the deviation exists.

#### **Emergency control** (Non follow up control)

The directional-control valve can be manually controlled by means of the emergency control buttons fitted both at the bridge steering console and locally at the control valve.

#### **Automatic separation control system (Safematic system)**

According to international regulations, the steering gear system of larger ships must be provided with automatic separation of the two hydraulic systems, in case of a large oil leakage at one of the systems.

Both steering gear systems are connected to the common expansion tank.

A major oil leak at one of the systems will lead to a decrease of the oil level in the expansion tank and a “LOW LEVEL ALARM - EXPANSION TANK” is activated.

If the oil level continues to decrease, both steering gear pumps receive a START command resulting in a start of the stand by steering gear pump.

If the expansion tank oil level is still decreasing, it will reach the level where the expansion tank is split up into two chambers by an internal partition plate. Each steering gear system is now supplied from its own expansion tank chamber and the decrease in oil level will only take place in the chamber connected to the defective system. A low level switch in the chamber in question stops the respective steering gear pump and shifts the safematic control valve block into a position where:



- the two systems are separated from each other
- the steering gear chambers connected to the defective system are by-passed (short-circuited).

After the separation the defective system will be shut down (pump stops, control valve block will close).

**NOTE**

In this condition, the steering gear torque is reduced and the ship's speed must immediately be reduced to 14 knot and the rudder angle must not exceed 15°.

The separation system can be tested by draining the expansion tank.

The systems can also be separated manually by means of the Safematic valve block and the by-pass valves.

**Operation procedure**

**1. Preparation**

- 1.1 Check content in hydraulic oil tanks, refill if necessary.
- 1.2 Check that steering gear and expansion tank shut off valves are open.
- 1.3 Check that Safematic valve block valve is open.
- 1.4 Start steering gear pump(s) locally or remotely from control room or bridge.

Testing of steering gear should be carried out before leaving port. This is normally carried out from the bridge.

**2. Pumps**

- 2.1 During normal operation at sea only one pump is in operation
- 2.2 During manoeuvre and in congested waters two pumps must be in operation.

- 2.3 Starting and stopping of the pumps can be carried out locally or remote via the Power Chief - Pump Control system or from the bridge steering consoles.

**3. Drain and oil filling**

- 3.1 Oil and water drainage from the steering gear systems can take place from:
  - 3.1.1 The bottom of each chamber in the common expansion tank.
  - 3.1.2 The bottom of each steering gear pump unit tank
- 3.2 Oil filling is done via the filling valve fitted at the expansion tank.

**4. Rudder commands**

- 4.1 Rudder command can be set manually on the autopilot.
- 4.2 To set specific rudder commands, select MAN and enter numeric values in %.
- 4.3 Autopilot can be set to specified course commands at bridge steering console.
- 4.4 Select ON and enter course.
- 4.5 Servo speed is dependent on servo oil pressure.
- 4.6 In bad weather, two pumps can be run to obtain quicker servo response to auto pilot.
- 4.7 To use the emergency steering select OFF on the autopilot.
- 4.8 Emergency control can be operated locally or from the bridge console.

Note that if a failure of automatic control of by-pass and Safematic valves should occur, these valves have to be operated locally.

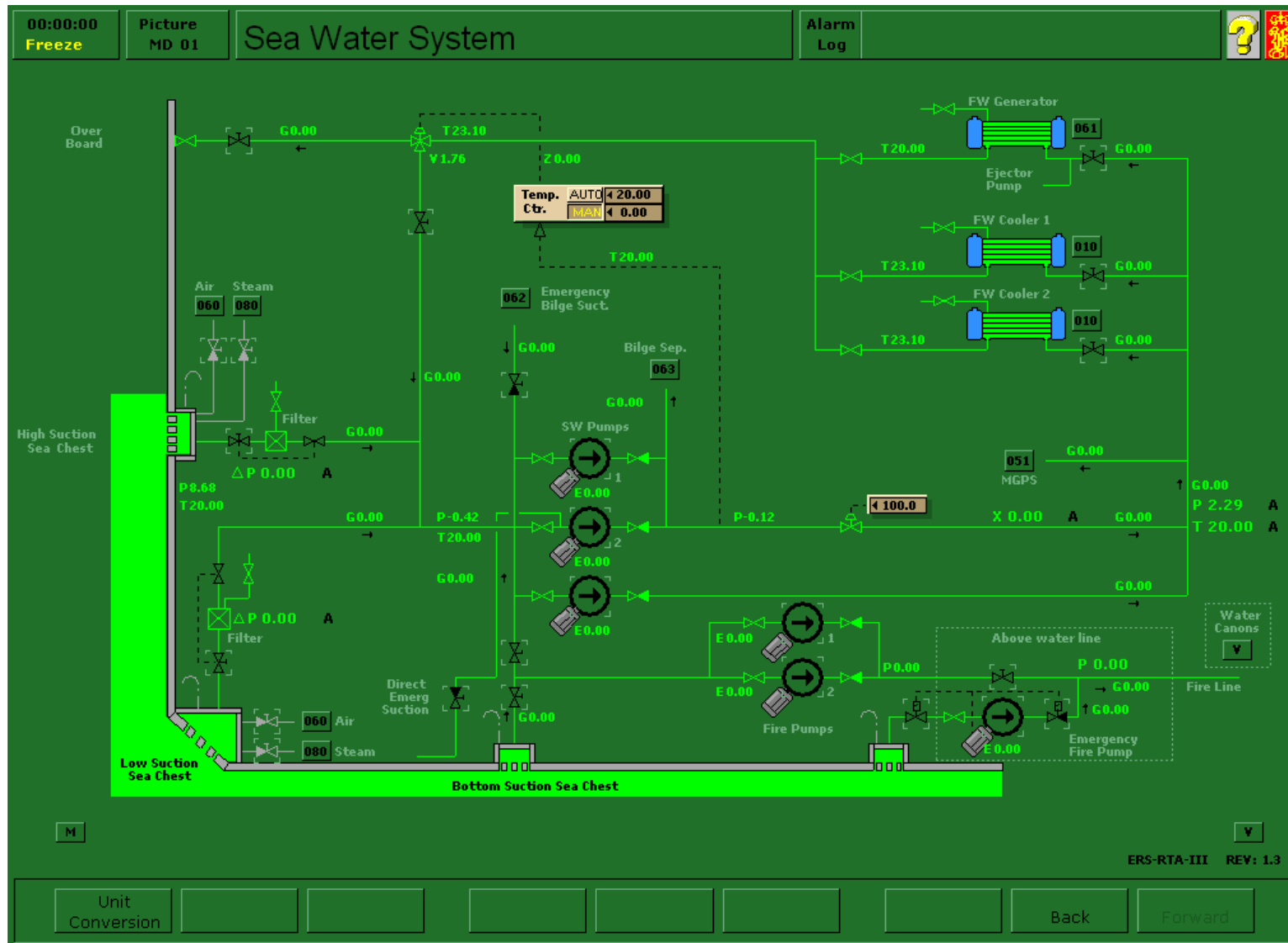



## 5 SERVICE SYSTEMS

### 5.1 Main Sea Water System

#### General

Sea water is circulated by two main and one auxiliary electrically driven SW pumps from sea chests through suction filters. The flow from the pumps goes to three coolers, which are connected in parallel:

- Fresh Water Cooler 1
- Fresh Water Cooler 2
- Fresh Water Generator

Sea water is also fed to a marine growth protection system.

#### Description

Sea water is taken from either a high suction sea chest via a filter when the vessel is loaded or a low suction sea chest when the vessel is in ballast. The sea chests have both steam and air weed clearing fitted.

In order to avoid too low sea water temperatures at the cooler inlets a controllable re-circulation valve is used to circulate water from the overboard line back to the common sea water suction line.

The re-circulation valve is pneumatically operated and controlled by a standard PID controller. The re-circulation line is smaller and has higher flow resistance than the overboard line. The total sea water flow will therefore be reduced in the re-circulation line.

A choke valve is provided for reduced sea water flow.

Two fire pumps are provided to service the fire main system. They take suction from a bottom suction sea chest and can also take suction from the main sea water service pump suction line.

The SW pumps can be used as emergency bilge pumps in the case of flooding via a connection to the main bilge line. No 2 main SW pump can be used for emergency bilge injection. A separate pipe to the tank tops is provided for this operation. When using the Bilge Injection ensure the sea chest suction valves are closed.

The emergency fire pump has a separate suction from its own sea chest.

Auxiliary SW pump is supplied from the emergency switchboard.

#### Operation Procedure

- 1.1 Open relevant sea suction and discharge valves.
- 1.2 Open valves to relevant coolers. Under normal circumstances only one fresh water cooler need to be in use.
- 1.3 Set controller for re-circulation valve to auto and 20°C.
- 1.4 Start one sea water pump locally.
- 1.5 Put one pump in Auto mode from pump/compressor control panel. Normally one pump is running and one is set to standby.

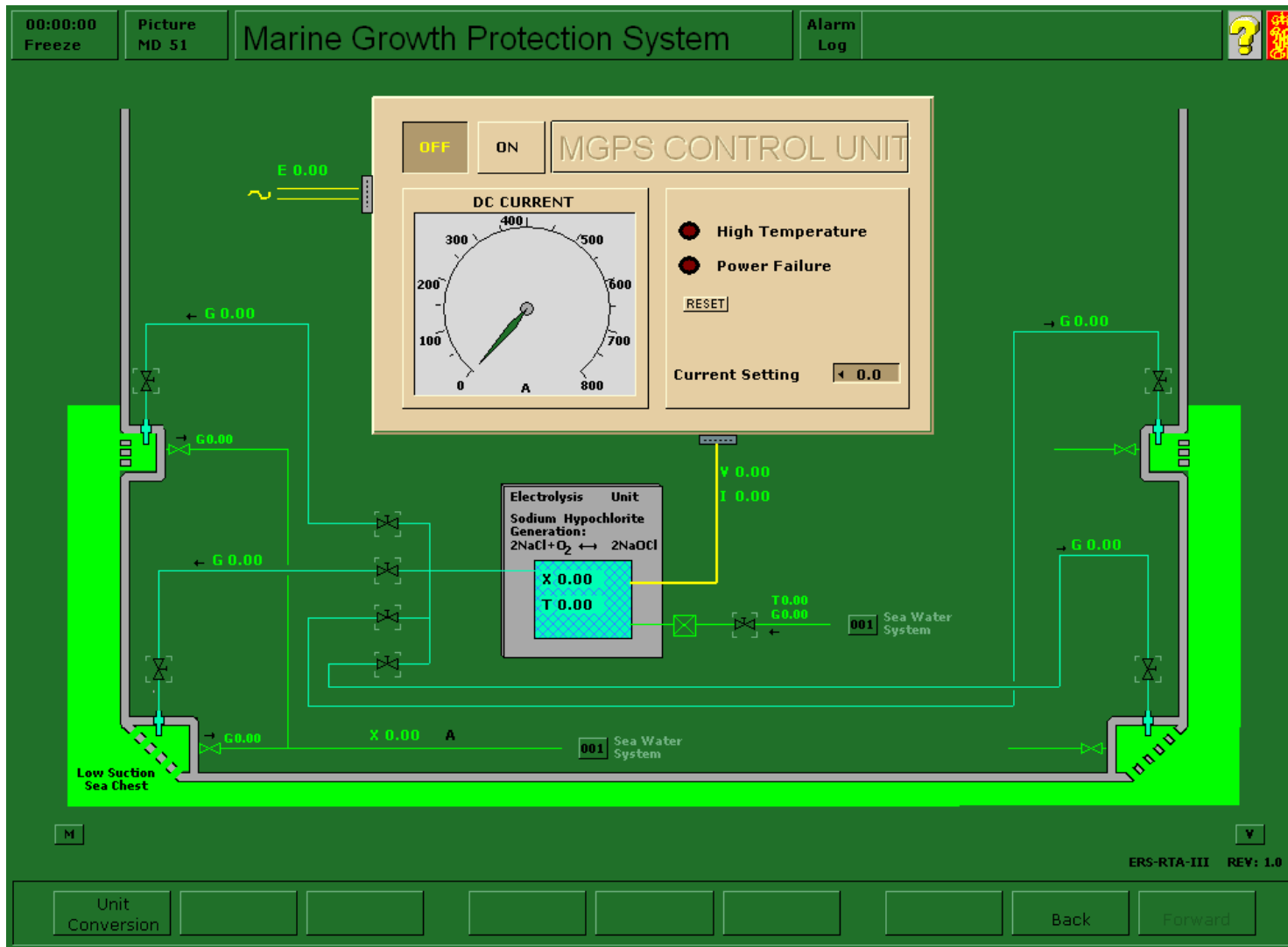





### 5.1.1 Marine Growth Protection System

The sea water system is equipped with a hychlorator system, of which a leading manufacturer is MGPS system.

The hychlorator system is used for the electro-chlorination of seawater used in the sea waters cooling system. It works by producing Sodium hypochlorite from seawater as it flows through an electrolyser fabric of anode>cathode>anode which are connected to a current source.

The sodium hypochlorite produced has the effect of sterilizing the salt water, thereby eliminating any marine growth and biological compositions that can otherwise damage and foul the cooling system and other seawater based system components.

MGPS control unit creates an antifouling agent, sodium hypochlorite (NaOCl), directly from seawater, which is distributed to the sea chests and seawater piping system for protection against all types of fouling. MGPS operates by using an electrolytic cell containing titanium anodes to transform the salt in seawater into sodium hypochlorite (NaOCl) through a process of electrolysis.

Electrolysis begins when the current is switched on at the control panel and the valves are opened. The resulting sodium hypochlorite is piped to the injection nozzles where the disinfecting agent is injected into the sea chests to mix with incoming seawater to prevent fouling in the whole seawater system. The system consists of three parts:

Control panel (located near electrolysis group)

Electrolysis group (located in the engine room near the sea chests)  
Injection nozzles (located in sea chests, connected to the electrolysis group via pipes and control valves)



A picture of the electrolytic cell producing an antifouling solution to keep the sea chests and sea water circuits free from fouling.



#### Operation Procedure



- 1.1 Ensure sea water system has flow
- 1.2 Open sea water valve and injection nozzle of valve chest in use
- 1.3 Turn on control unit and adjust current to give a hypochlorite level of approximately 1.5ppm in the sea water system.
- 1.4 If sea suction are changed remember to change the injection nozzle.

00:00:00  
Freeze
Picture  
MD40

## Air Ventilation System

Alarm  
Log

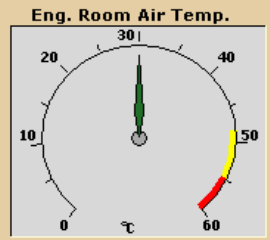
<b>Eng. Room Air Temp.</b> 	<b>Eng. Room Air Pressure</b> 	<b>Total Fan Power</b> 	<b>Ambient Air Temp.</b> 
<b>Eng. Contr. Room Fan</b> <input type="button" value="START"/>	<b>Eng. Room Supply Fans</b> <input type="button" value="No 1 LOW"/> <input type="button" value="No 1 HIGH"/> <input type="button" value="No 2 LOW"/> <input type="button" value="No 2 HIGH"/>	<b>Purifier Room Fan</b> <input type="button" value="START"/>	
<b>Cargo Holds Fans</b> <input type="button" value="START"/>	<b>Eng. Room Exhaust Fans</b> <input type="button" value="No 1 REV."/> <input type="button" value="No 1 LOW"/> <input type="button" value="No 1 HIGH"/> <input type="button" value="No 2 REV."/> <input type="button" value="No 2 LOW"/> <input type="button" value="No 2 HIGH"/>	<b>Sewage Room Fan</b> <input type="button" value="START"/>	
<input type="button" value=""/>	<b>Accommodation Fans</b> <input type="button" value="No 1 START"/> <input type="button" value="No 2 START"/>	<input type="button" value=""/> <div style="display: flex; justify-content: flex-end; margin-top: 5px;"> <input type="button" value="075"/> <input type="button" value="013"/> </div>	

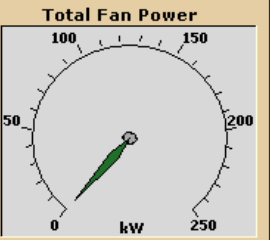
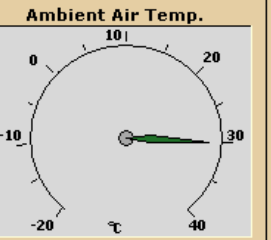
Fire Protection

104

ERS-RTA-III REV: 1.1



## 5.2 Air Ventilation System

### General

#### Engine room:

The system consists of two axial flow, two speed, supply fans (one PS and one SB) and two reversible, two speed extractor fans.

Each ventilator has a capacity 25.000 m<sup>3</sup>/h.

The supply air is distributed to the hot areas of the engine room through ducts to adjustable nozzle outlets.

The air exhausts through the funnel and through flaps in the casing top, which can be closed in the event of fire. In case of fire, the ventilation can be shut down by means of pneumatically operated flaps fitted to the louvers and remotely operated from either the deck office or outside the funnel in casing top.

#### Purifier room

For removal of dangerous oil vapour from the purifier room, a centrifugal extractor ventilator is located at E-deck PS.

The ventilator has a capacity of 18.000 m<sup>3</sup>/h.

#### Sewage room

For removal of possible hydrogen sulphide and methane vapours from the sewage room, a centrifugal extractor ventilator is located at E-deck SB.

The ventilator has a capacity of 8.000 m<sup>3</sup>/h.

The ventilation panel gives indication of engine room and ambient temperature as well as engine room air pressure.

When the CO<sub>2</sub> cabinet door is opened, engine room supply and exhaust fans are stopped.

No.2 engine room fans are supplied from the emergency switchboard for CO<sub>2</sub> removal and emergency ventilation. All other fans are supplied from the non-essential bus bar

- engine room: 2 supply fans each with low or high speed. – 2 x 10/27 kW
- engine room: 2 exhaust fans each with low or high speed and the possibility of reversing the direction of the rotation. – 2x8/24 kW
- engine control room: 1 supply fan. – 7,5 kW
- cargo holds controlled as one fan: 6 fans – 6 x 20 kW
- purifier room: 1 exhaust fan - 12 kW
- sewage room: 1 exhaust fan - 5 kW
- accommodation: 2 supply fans – 2 x 15 kW

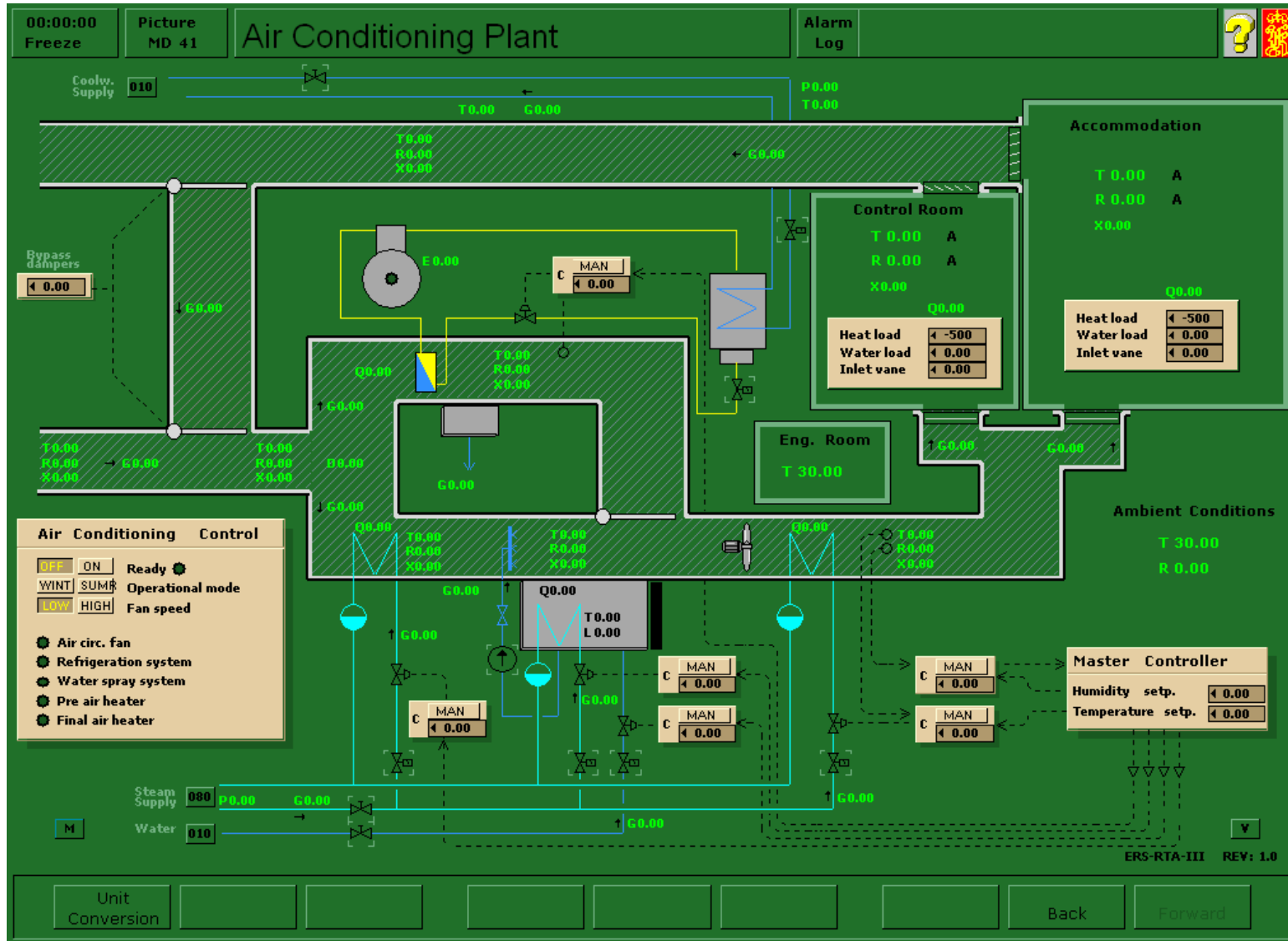



## 5.3 Air Conditioning Plant

### Introduction

The air is supplied to the accommodation and the engine control room by an air handling unit (AHU) located in the air conditioning unit room situated in the accommodation block on the starboard side of the upper deck (accessed from the engine room).

The AHU consists of an electrically driven fan drawing air through the following sections from inlet to outlet:

- One air filter
- One steam preheating unit
- A humidifier section
- One steam final heat section
- One air cooler evaporator coil
- A water eliminator section
- A fan section
- A discharge section

Humidification of the air is arranged with automatic control and this is fitted at the outlet part of the AHU.

The air is forced into the distribution ducting, which supplies the accommodation and the engine control room.

The system is designed for fresh air with heat recovery by means of two bypass dampers using a part of the heat in the outgoing stale air.

Cooling is provided by a direct expansion R134a system. The plant is automatic and consists of one compressor/condenser units supplying the evaporators contained in the accommodation air handling unit. The expansion valve for the coil is fed with liquid refrigerant from the air conditioning compressor, the refrigerant having been compressed in the compressor then cooled in the condenser where it is condensed to a liquid. The liquid R134a is

then fed, via dryer units, to the evaporator coils where it expands under the control of the expansion valves, before being returned to the compressor as a gas. In the evaporator coil, it extracts heat from the air passing over the coils.

Air is circulated through ducting to outlets in the cabins and public rooms.

The plant is controlled by a master controller where it is possible to set the set point for humidity and temperature before the inlet to the accommodation and ECR.

Summer or winter operation may be selected on the air conditioning panel in the engine room.

The bypass dampers allow recirculation of the air if the ship is in poor ambient conditions i.e. in harbour with a sandstorm.

Normally the bypass dampers must only be opened 30% to reduce the recirculation of bad air spreading such things as colds etc. through the vessels personnel.

### 1 Winter operating procedure:

- 1.1 Prepare and start the steam supply for the pre- and final heating section in AUTO mode.
- 1.2 Prepare and start the water supply for the humidifier section in AUTO mode.
- 1.3 Set the bypass damper at 10%.
- 1.4 Start the plant in winter mode with low fan speed.
- 1.5 Set the master controllers set points at the wanted values.
- 1.6 Control the plant with appropriate intervals and adjust the plant if necessary.



**2. Summer operating procedure:**

- 2.1 Prepare and start the steam supply for the final heating section in AUTO mode.
- 2.2 Prepare and start the water supply for the condenser.
- 2.3 Set the bypass damper at 10%.
- 2.4 Start the plant in summer mode with low fan speed.
- 2.5 Set the master controllers set points at the wanted values.
- 2.6 Control the plant with appropriate intervals and adjust the plant if necessary.

**Note:**

It is possible to adjust the capacity of the plant by opening/closing the bypass damper and/or low/high speed of the fan.

**Note:**

Steam valve V15605 and water valve V15606 must be open for starting the plant.

**Note:**

Pressing the MAN buttons on the controllers, they will change to AUTO mode and visa versa.

The compressor starts when pressing the ON button on the control panel.



## 5.4 Sewage Treatment

### Sewage Treatment Plant

Type: Biological oxidation and discharge

Capacity: 38 persons

One aeration compressor

One sludge pump

One effluent pump (discharge overboard)

One tablet chlorination dispenser

One sewage sludge tank (at the incinerator system)

Sewage from the accommodation spaces flows through pipes, under the effect of a vacuum collection system, to the sewage treatment plant located in the machinery space.

The sewage treatment plant is a biological unit which works on the aerobic activated sludge principle. The plant will treat black and grey water and is fully automatic in operation.

This sewage treatment plant consists of a tank with three main compartments:

- Aeration compartment
- Settling tank (clarification) compartment
- Chlorination and discharge compartment

### Aeration tank

The sewage in this compartment is from the lavatory pans, urinals and hospital in the accommodation spaces. The incoming effluent material mixes with the activated sludge already present in this compartment. Air is supplied by means air pipes and distributed through the tank by aerators. The gas produced during the bacterial action which takes place is vented to atmosphere. Oxygen is essential for the aerobic activity. The organisms require oxygen for

digesting the raw sewage and it also assists in mixing the incoming sewage with the water, sewage sludge and bacteria already present in the compartment.

A screen at the outlet from the aeration compartment prevents the passage of inorganic solids to this compartment.

### Settling tank

The mixed fluid passes into this compartment and settles out into sludge and liquid. The water passes into the treatment and discharge compartment, whilst the remaining sludge, which contains the active bacteria, returns to the aeration compartment by means of an air lift tube for further processing. The surface is skimmed of detritus which is returned it to the aeration compartment.

### Chlorination and Discharge tank

Water from the clarification section is mixed with disinfectants (sodium hypochlorite) and is sterilised. The compartment has float operated switches which activate the effluent pump (discharge) when the high level is reached and stop the pump when the compartment is nearly empty. Chemical dosing is by means of tablets added to the basket in the chamber and these dissolve slowly when in contact with the water in the chamber as the water level rises.

### CAUTION

**Discharge overboard of untreated sewage should not take place within 12 nautical miles of the coast and local restriction concerning treated sewage discharge must be strictly observed.**



The sewage treatment plant works automatically once it is set but periodic attention is required and the unit must be monitored for correct operation.

(**Note:** Rules governing the discharge of raw sewage must be complied with at all times and the discharge of raw sewage overboard must only be contemplated should the sewage plant be out of service. The bacterial action requires a regular supply of raw sewage and the discharge of raw sewage overboard can impair effective bacterial action.)

### Operating the Sewage Treatment Plant

There is a black water supply from the vacuum collection system and a grey waterline supply from the galley and laundry system.

In both supply lines there is a control valve.

The effluent pump has a direct connection to the overboard discharge line.

Set the system valves as in the following table:

- Open overboard valves in the discharge line from the effluent pump
- Open suction valve from chlorination tank
- Close suction valve from settling tank
- Close suction valve from aeration tank
- The sewage treatment unit should be initially filled with water
- Activated sludge shall be added if it has been emptied for any reason or when commissioning the plant for the first time. This will not be required when the unit has been operating previously but the description is included for completeness.

- Check that effluent pump is selected for operation.
- Check that dosing chemical tablets have been added to the basket in the discharge chamber.
- The sludge and the effluent pumps are set in “auto” mode.
- Open diffuser and air lift valves
- Start the aeration compressor.
- Set the UV radiation unit on.
- Start to supply the unit with black/grey water.
- Operate the unit to maintain output levels within Marpol IV requirements.

At high level in the chlorination tank, the bypass valve will open across the UV radiation unit.

### 1 Operation in local restriction areas

- 1.1 Open the valve to the sewage sludge tank
- 1.2 Close the valve before the UV unit.
- 1.3 Check the levels in the sewage sludge tank and in the oil sludge tank.
- 1.4 The sewage unit discharge can be stored and disposed of later, solids via the incinerator, liquids via the OWS.



<This page is intentionally left blank>

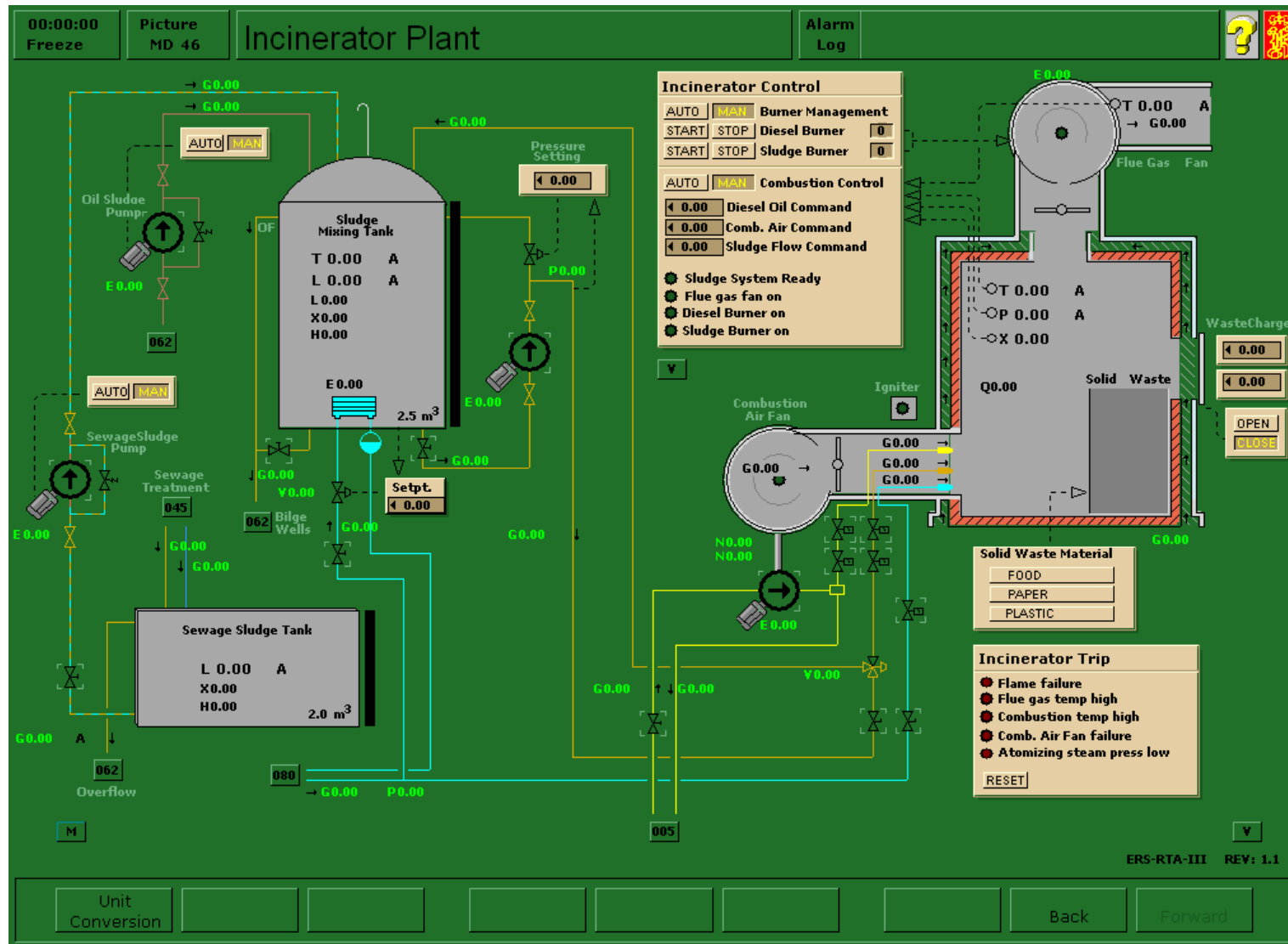



## 5.5 Incinerator

### General:

It is possible to burn sludge from the sewage system or from the oil sludge system in the incinerator.

The incinerator has to run on diesel oil together with sludge and/or solid waste.

- One sewage sludge pump.
- One sewage sludge tank.
- One sludge pump taking sludge from the oil sludge tank placed near the bilge system.
- One sludge circulation pump
- One combustion unit placed at the front of the incinerator consisting of a combustion air fan, 2 DO valves, 2 sludge valves.
- One incinerator with a waste charge unit for solid waste material.
- One incinerator control unit with manual/auto mode and incinerator trip unit.

### CAUTION

**Burning sludge/solid waste should not take place within 12 nautical miles of the coast.**

The incinerator plant works automatically once it is set but periodic attention is required and the unit must be monitored for correct operation.

(**Note:** Rules governing the burning sludge/solid waste must be complied with at all times.)

### Start procedure

- 1 Solid waste can be added by opening the door, adding paper, plastic, food and closing the door.
- 2 The incinerator controller must be in “manual” mode and the combustion controller in “auto” mode.
- 3 Heat the sludge in the mixing tank to about 85°C by supplying steam and circulate with the circulating pump.
- 4 Drain any free water from the sludge mixing tank
- 5 Open sludge mixing tank outlet valve
- 6 Open DO supply, sludge supply and atomising steam valve
- 7 Start DO burner in manual.
- 8 When the DO burner is burning OK, start the sludge burner.
- 9 In order to run in full ‘auto’ operation then sludge system must be ready.

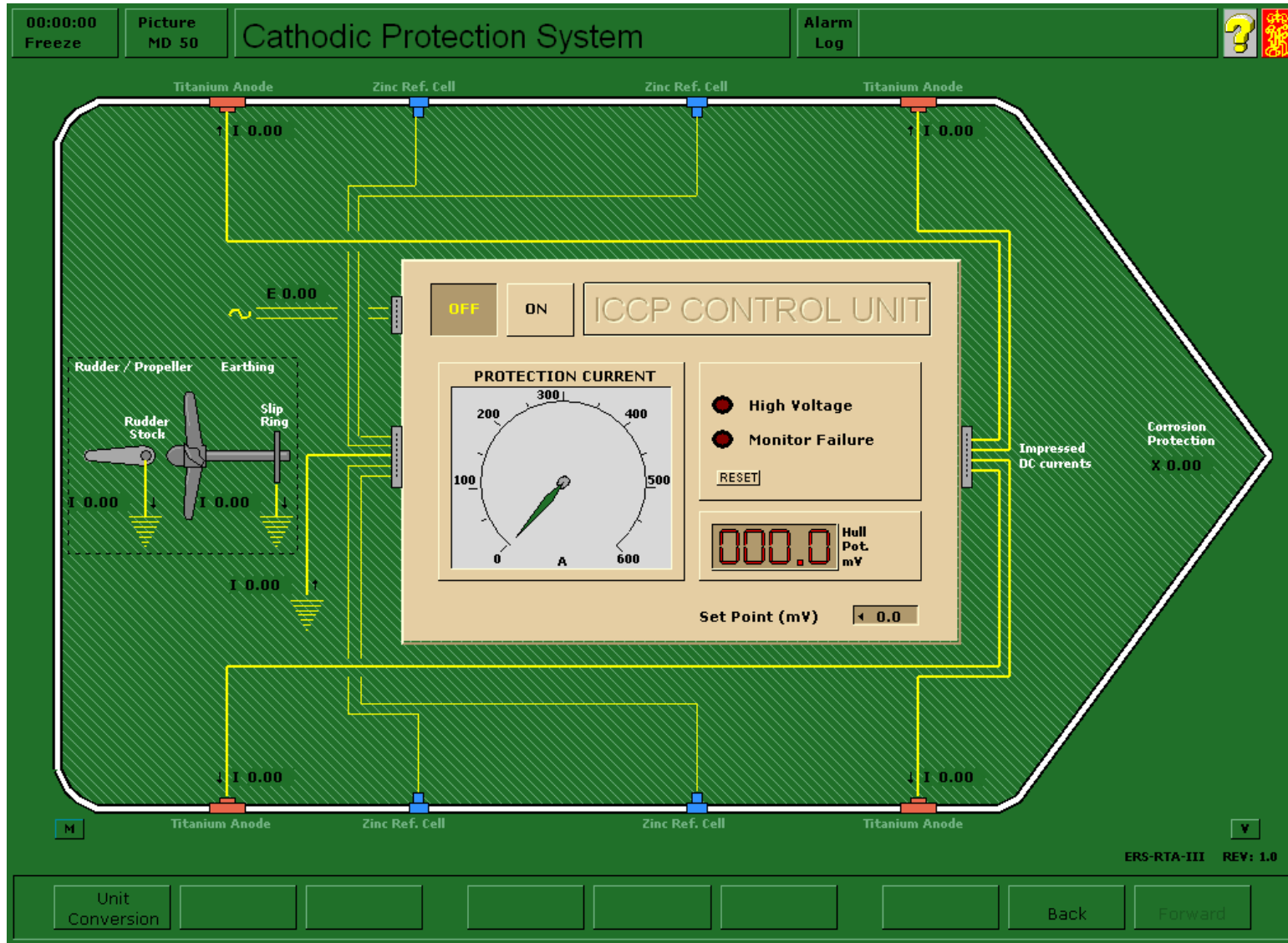

## 5.6 Cathodic Protection System ICCP

Type: Impressed current

Power supply: AC 440V, 60Hz

The vessel is provided with an Impressed Current Cathodic Protection (ICCP) system. This method of corrosion protection automatically controls electrochemical corrosion of the ship's hull structure below the waterline.

Cathodic protection can be compared to a simple battery cell, consisting of two plates in an electrolyte. One of the battery plates in the electrolyte will waste away through the action of the flow of electrical current, if the two battery electrodes are connected electrically. When two metals are immersed in sea water, which acts as the electrolyte, one of the metals acts as the anode and will waste away. Which metal, in any pair, acts as the anode depends upon their relative positions in the electrochemical series but steel will act as an anode to copper, brass or bronze. The strength of the electric current generated in the corrosion cell, and hence the rate at which wastage takes place depends upon the metals involved and the strength of the electrolyte.

If a third electrode is added to the cell and current is forced to flow, the third electrode now acts as the anode and the old anode (hull) will act as the new cathode.

When a vessel is fitted with ICCP, the hull steel is maintained at an electrical potential more negative than the surrounding sea water. For this reason, loading and discharging terminals normally comply with the ISGOTT Recommendation 20.6, Earthing,

Bonding and Cathodic Protection, which states, that ship shore bonding cables should be discouraged. High currents that can occur in earthing cables and metallic connections are avoided. These are due to potential differences between ship and terminal structure particularly due to the residual potential difference that can exist for up to 24 hours after the shipboard ICCP has been switched off. These terminals usually utilise insulating flanges on hose connections to electrically isolate the ship and terminal structure. During preparations for berthing at terminals where such insulation is not employed, or where earth connections are mandatory by local regulation, or when bunker barges come alongside, the ICCP should be switched off at least 24 hours in advance.

### Fresh Water Operation

When the vessel enters a river estuary, the fresh or brackish water may limit the spread of current from the anodes, due to the higher resistance of the water.

Normally, the voltage output increases to compensate for this and would be accompanied by very low current levels and the reference electrode potentials may indicate under protection. However, in this system, the output is adjusted automatically and the system returns the hull to the optimum protection level when the vessel returns to sea water.



### Principle of Operation

Protection is achieved by passing low voltage DC current between the hull metal and anodes, insulated from the hull, but in contact with the sea water.

The electrical potential of the hull is maintained more negative than the anodes, i.e. cathodic. In this condition corrosion is minimised. Careful control is necessary over the flow of impressed current, which will vary with the ship's speed, salinity and temperature of the sea water and the condition of the hull paint work. If the potential of the hull is made too negative with respect to the anode, then damage to the paint film can occur electrolytically or through the evolution of hydrogen gas between hull steel and paint. The system on this vessel controls the impressed electrical current automatically to ensure optimum protection. Current is fed through titanium anodes situated port and starboard on the ship. The titanium prevents the anodes themselves from corroding and the surfaces are streamlined into the hull. Fixed zinc reference electrodes port and starboard are used to compare the potential of the hull with that normally found between unprotected steel and zinc electrodes. Sufficient current is impressed via the anodes to reduce this to a level of between 150 and 250mV.

### Operation

Once the unit is switched on, the unit's transformer rectifier converts the ship's 440V AC supply to a low voltage finely controlled DC current, the positive is connected to the anodes and the negative is connected to the ship's hull.

The system is completely automatic in normal use. In the normal operating mode, the display will show the following readings:

- Anode current and voltage
- Set point mV AVE (average value)

The system should be regularly monitored and the readings taken once a day.

### Electrical Installation

The system consists of a monitoring panel and two rectifier units. The rectifier units, one forward and one aft, are wired to port and starboard reference electrodes and port and starboard anodes. The monitoring unit is also equipped with facilities to raise an external alarm to give warning of any system abnormalities, via the main alarm system.

### Propeller and Rudder Stock Earthing

To avoid electrolytic corrosion of the propeller shaft, a slip ring is clamped to the shaft and is earthed to the hull via brushes. A second set of brushes, insulated from earth, monitors the shaft mV potential and this signal is fed to a millivolt meter. To ensure efficient bonding, the slip ring should be cleaned on a regular basis. The shaft potential value should ideally remain below 75mV. The rudder stock is also earthed for protection via a flexible copper earth cable between the deck and rudder stock to minimise any electrolytic potential across the bearings and bushes.

### Routine Checks

- 1 Record the output current and all voltages on a daily basis.
- 2 Check the reference electrode voltage on a daily basis.
- 3 Check and clean the propeller shaft slip ring and brushes every week.
- 4 Inspect the rudder stock earth strap every month.



- 5 Return completed log sheets to the manufacturer for scrutiny every month.
- 6 Inspect and clean the control unit cooling fans and grills every three months.
- 7 The anodes and reference cells must be externally inspected every dry dock period. The anodes are fitted with an insulating shield cover to prevent excessive local over-protection and the condition of this shield must be closely inspected at this time.
- 8 Detailed instructions are available in the manufacturer's manual.

### **Sacrificial Anodes**

The areas of the hull shielded from the hull face, such as thruster tunnels, rudder and sea water intakes, receive only limited protection from the ICCP system. These areas are therefore fitted with separate sacrificial anodes. Several sacrificial zinc anodes are provided within each of the water ballast tanks.

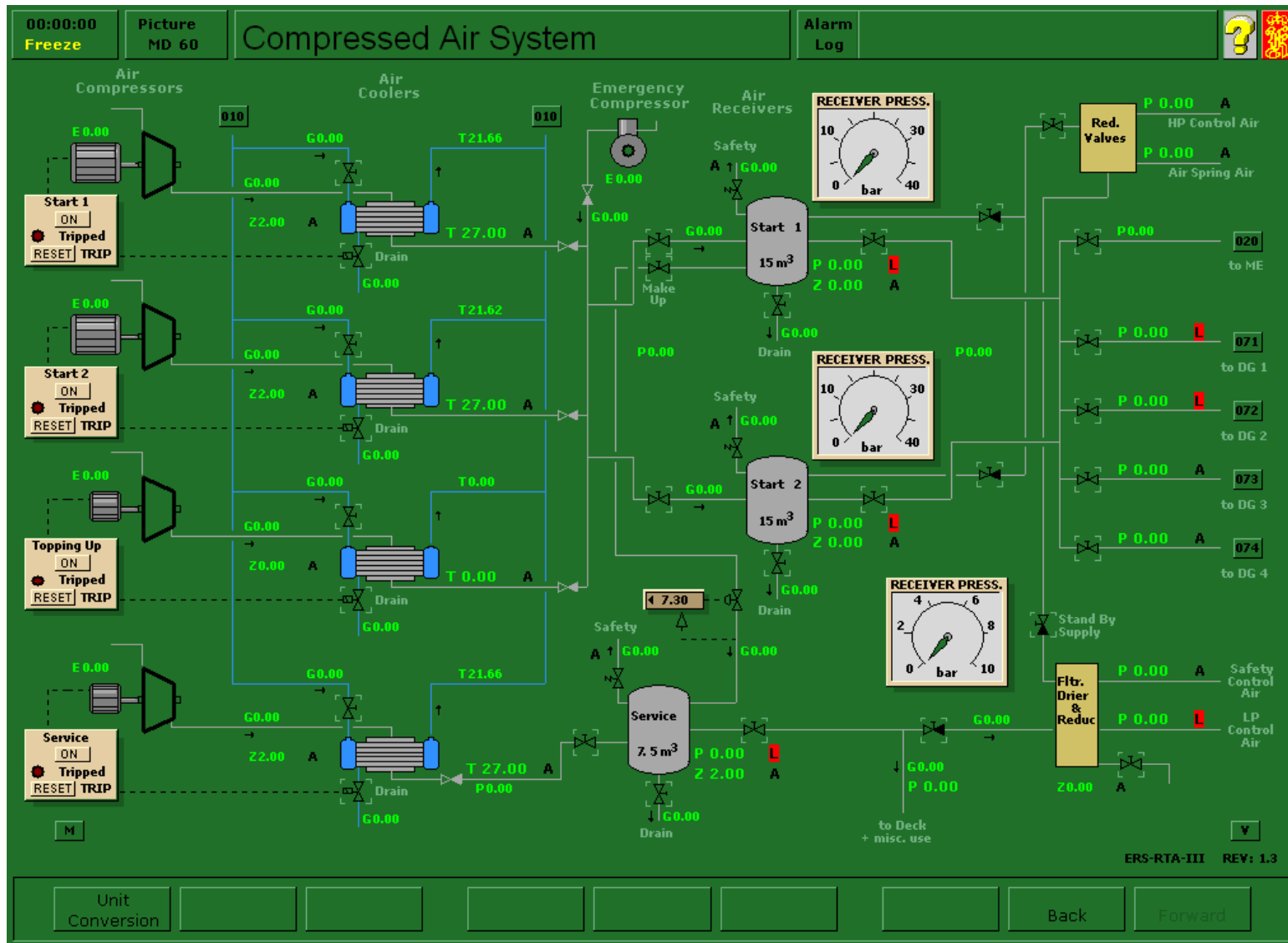





## 5.7 Starting Air Compressors

### General

The purpose of the start air is to provide starting air to the diesel engines and ensure that first start is available should all power to the vessel be lost.

The compressed air system consists of:

- two start air compressors
- one topping up compressor
- one service air compressor
- one emergency air compressor
- two start air receivers
- one service air receiver
- 4 air coolers with drain valves
- reduction valves for HP control air and air spring for exhaust valves
- filter, drier and reduction unit for safety control air and LP control air.

All compressors start and stop automatically according to need by the compressor control system included in the Power Chief system if the compressor is in AUTO position. The emergency compressor is supplied from the emergency switchboard.

### Description

Each air compressor is monitored by an independent, local safety system.

The air compressors will trip at:

	Start air comp.	Emergency air comp.
Disch. air temp.	> 110°C	> 110°C
Lub oil press.	< 0.75 bar	< 0.75 bar

The start, topping up and service air compressors are cooled by LTFW. The emergency air compressor is air cooled.

Trip condition is indicated by a red alarm light on the compressor panel.

The starting air compressors are normally operated with one compressor selected as Master. This is achieved at the Power Chief panel. Master cut in and cut out setting can be set on variable page 6020.

The start air receivers can be operated in parallel, or one of the receivers can be pressurised and shut off in order to be kept as a standby receiver. The main and the auxiliary diesel engines are supplied by separate air lines and stop valves from one or both of the air receivers.

The safety valves for the start air receivers open at approximately 32 bar. The settings of the safety valves can be changed from the variable page.



If the service air compressor fails, make-up air can be taken from the #1 start air receiver. The air make-up valve is usually left open for safety reasons. If the service air compressor trips, service and control air pressure is not lost, but supplied through the starting air receivers. This may prevent a serious situation like a shut down of the main engine in narrow waters. Carefully consider if or when to close the service air make-up valve.

An emergency supply for the LP control air is supplied from the air spring reduction valve.

### Operation procedure

#### 1. Preparations before starting start air compressors after a longer period out of operation.

- 1.1 Check that main sea water system and LT fresh water system are in operation and that the valve to air compressor coolers is open.
- 1.2 Open fresh water inlet valve(s) to start air cooler(s).
- 1.3 Open drain valve(s) from start air cooler(s).
- 1.4 Open air inlet valve(s) to start air receiver(s).
- 1.5 Open air outlet valve(s) from start air receiver(s).
- 1.6 Operate drain valve(s) from start air receiver(s) to ensure that no water is present.

#### 2. Starting procedure

- 2.1 If the selected compressor is tripped (TRIPPED lamp lit), press RESET button on the compressor panel. Start the compressor by pressing button ON.
- 2.2 Close drain valves.
- 2.3 Select AUTO mode on the Power Chief panel. Select the desired Master compressor. The compressors will then start and stop according to the limits given. These limits are adjustable from the variable page 6020. **Note:** When a compressor is started manually it is not stopped automatically by a pressure control.
- 2.4 When pressure in air receivers increases open air supply valve(s) to selected consumer(s).

#### 3. Normal operation

- 3.1 Normally all start air receivers are pressurised and in operation.
- 3.2 Both of the start air compressors are in AUTO mode with one selected as Master.
- 3.3 The service air compressor is in auto mode.
- 3.4 Emergency start air compressor in manual mode.
- 3.5 Air receivers and air coolers must be drained regularly.

<This page is intentionally left blank>

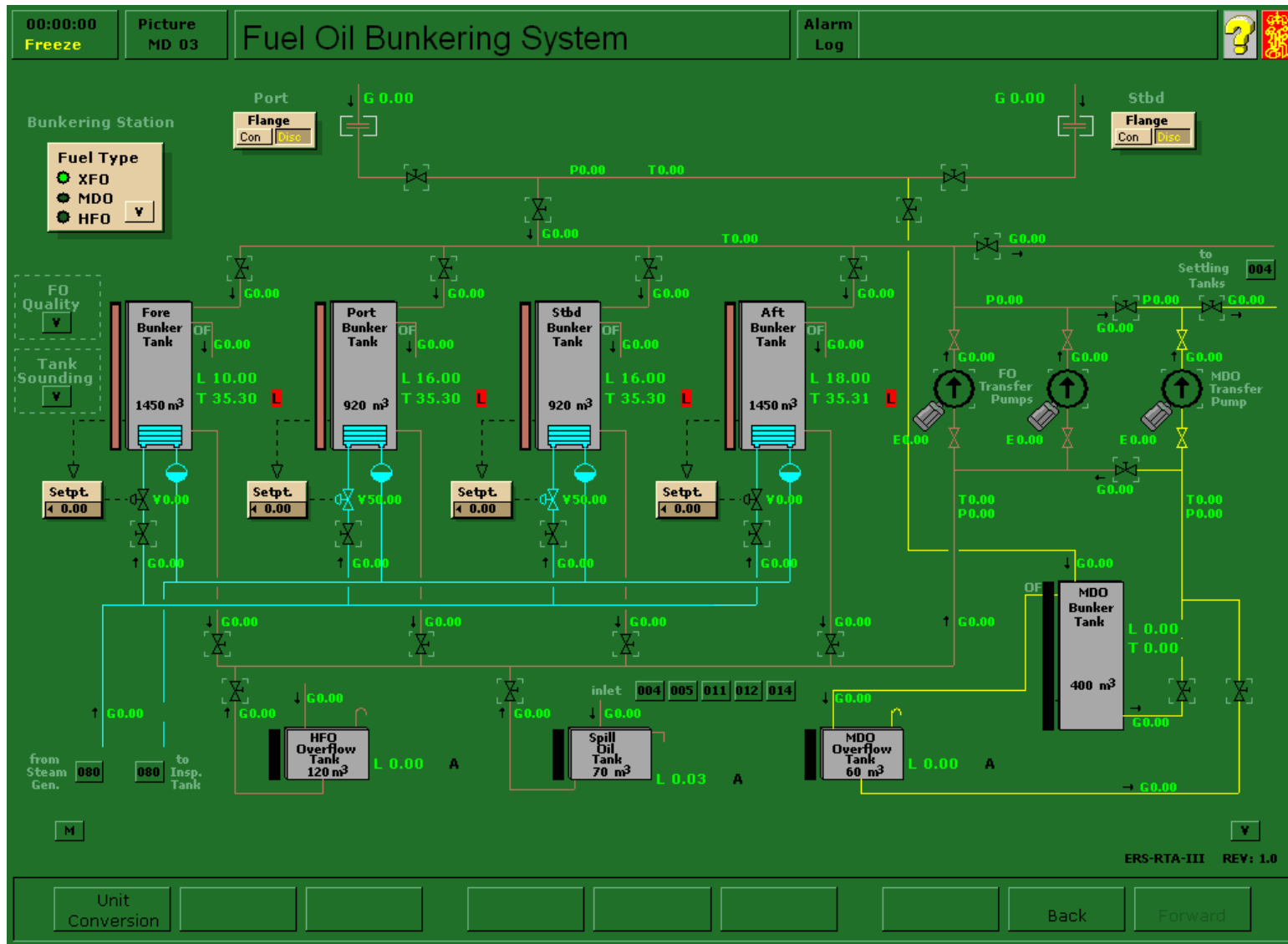



## 5.8 Fuel Oil Bunker System

### General

The heavy fuel oil transfer system includes:

- Four HFO bunker tanks
- One MDO bunker tank
- One HFO overflow tank
- One spill oil tank
- One MDO overflow tank
- Two HFO transfer pumps
- One MDO transfer pump
- Two filling stations port and starboard

No pumping should be attempted from any fuel tank before the oil is pumpable, meaning that the viscosity must be below about 700 cSt and that the fuel suction and pressure lines are open.

All heavy fuel tanks are equipped with heating coils and pipe lines in engine room with steam tracing.

When applying steam to steam tracing always be sure that the oil in the pipe system is free to expand. Never apply steam tracing to pipes where closed valves isolate a section.

The following tanks are drained to the spill oil tank:

- Settling tanks
- Service tanks
- FO system drains
- LO drain from ME system
- LO drain from turbocharger system

### 1 Operation procedure

- 1.1 Co-ordinate with the deck department before attempting to transfer fuel oil.
- 1.2 Open inlet to selected tank from HFO transfer pump.
- 1.3 Open outlet from selected bunker tank.
- 1.4 Observe that transfer of oil between bunker tanks is possible.
- 1.5 Start transfer pump after opening of outlet valve. Normally one pump is sufficient.

**Ensure that valves to bunker tanks are closed when transferring to settling tanks.**

Fuel oil in the bunker tanks is to be heated and kept at a temperature corresponding to the temperature at delivery.

**Note:** If large amount of heavy fuel is transferred to the settling tank, it may cause a considerable temperature drop in the settling tank, which again may cause purifier disturbance.

**Note:** Transfer of diesel oil is done with diesel oil purifier on separate instruction.



**Total HFO capacity on board 4740 m<sup>3</sup>.**

**2 Bunkering Procedure**

- 2.1 Observe all bunkering precaution prior to and during loading of bunkers
- 2.2 Ensure that overflow tank is empty
- 2.3 Select bunkers to be loaded by use of variable page 0320
- 2.4 Input fuel details of bunkers into variable page 0320
- 2.5 Open bunker tank filling valves as required
- 2.6 Connect flange and line up system ensuring shut off valve of opposite station is closed
- 2.7 At completion of bunkers ensure that all valves are closed

**Precautions to be observed prior to and during the loading of bunkers.**

The bunkering procedures must be observed at all times and all personnel involved in the bunkering procedure, whether planning or actual operation of bunkering, must be fully aware of the contents of Oil Transfer Procedures - Bunkering.

**It is essential that all personnel involved in the bunkering procedure know who is in charge of the bunkering operation.**

- The following licensed officers are designated as persons in charge: Chief Engineer Officer, Second Engineer Officer, Chief Officer.
- All engineers and other personnel involved in the bunkering process should know exactly what role they are to play and what their duties are to be.
- Personnel involved should know the location of all valves and gauges and be able to operate valves both remotely and locally as applicable.
- A bunker plan must be drawn up prior to bunkering and all personnel involved in bunkering need to be fully aware of the contents of the plan and understand the entire operational procedure.
- The Chief Engineer should calculate the estimated finishing ullages/dips, prior to the starting of loading.
- Shore or barge tanks, whichever form is being used, should be checked for water content.
- Representative samples are to be drawn using the continuous drip method for the duration of the loading operation dispatched for analysis. Samples should be taken at the bunker supply manifold inlet to the ship system.
- As far as possible new bunkers should be segregated from existing bunkers on board. If bunkers being received are to be loaded into the same tanks as existing bunkers on board, great care must be taken to avoid problems of incompatibility. If there is any doubt about the compatibility between the new and existing bunkers, the new bunkers should not be loaded on of existing bunkers.
- No internal transferring of bunkers should take place during bunker loading operations, unless permission has been obtained from the Chief Engineer.
- Bunker tanks should not exceed 95% full; high level alarms fitted at the 95% full level for all tanks.
- Any bunker barges attending the vessel are to be safely moored alongside before any part of the bunker loading operation begins.



- Level alarms fitted to bunker tanks should be tested prior to bunker loading operations.
- The soundness of all lines should be verified by visual inspection.
- The pre-bunkering checklist should be completed.
- When the final tank is full, the barge or shore station must be signalled to stop pumping.
- Close all bunker stations and tank filling valves.
- Open the bunker line vent valve and allow the hose to drain back to the supplier.
- Disconnect the hose and replace the blank at the bunker station connection.
- Check tank levels and agree quantity supplied, then, if satisfied, sign the bunker receipt.

- Ensure that the sample containers are properly sealed and have them despatched for analysis.

### **3 Fuel Oil Quality**

The overall fuel quality of the individual tanks can be found on variable pages 0330 to 0332. The quality depends on the fuel that was bunkered into the tanks.

### **4 Tank Sounding**

The quantity of bunkers on board may be calculated by using the tank sounding variables pages 0340 to 0344. Input variables are vessels trim and heel, tank level, density and temperature.

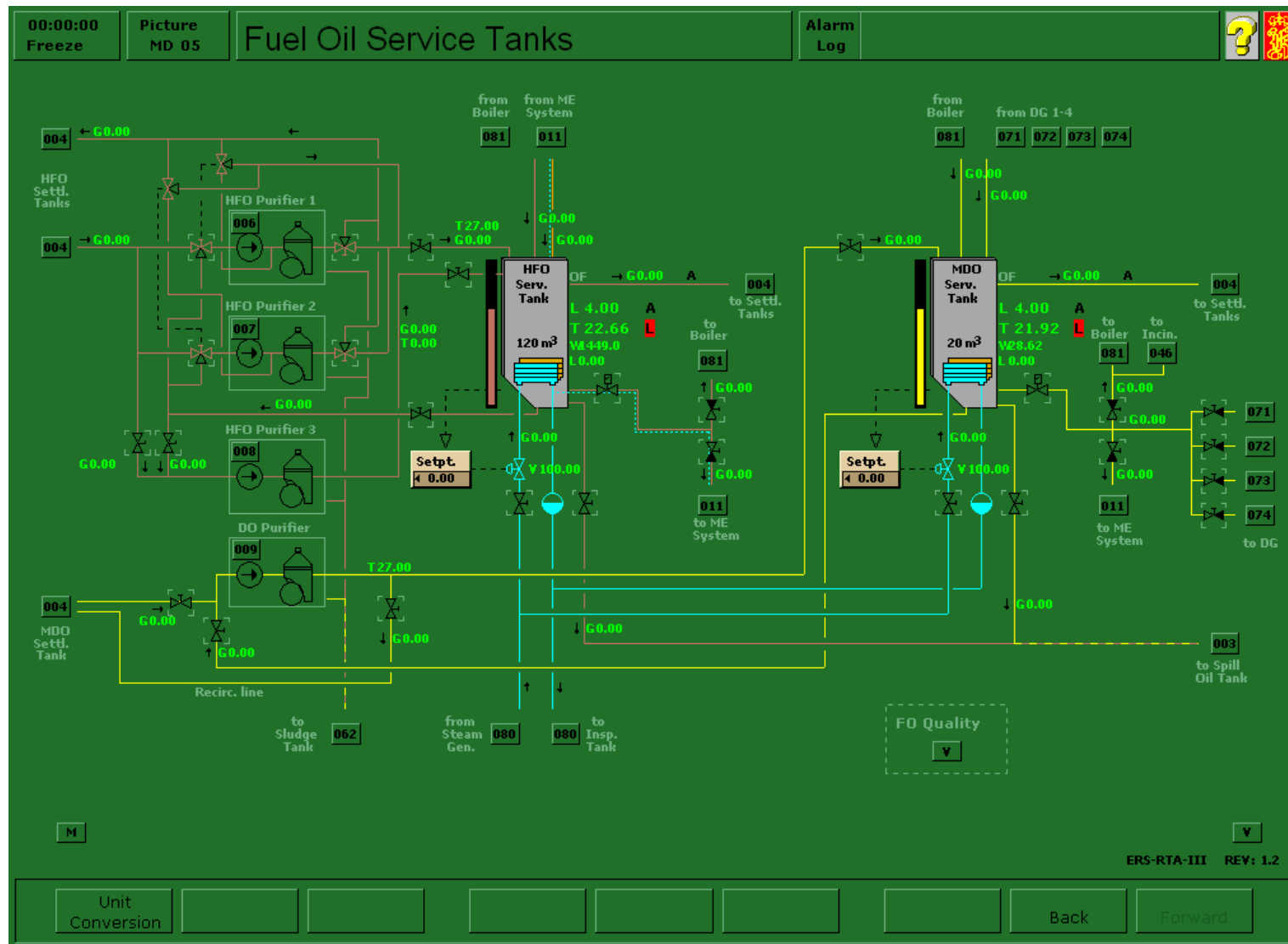





## 5.9 Fuel Oil Service Tanks

### General

Fuel oil service tanks comprise the HFO service tanks and the MDO service tank.

The fuel oil service tanks store and preheat the cleaned fuel oil.

The HFO service tank supplies fuel oil to:

- Fuel oil service system
- Boiler burner system

The diesel oil service tank supplies diesel oil to:

- Fuel oil service system
- Diesel generators
- Boiler burner system
- Incinerator system

### HFO purifiers

One HFO purifier capacity is enough for full speed of the ship, but normally two purifiers will be in service because of a better cleaning effect with lower flow rates.

Purifier 1 and 2 are ALCAP purifiers and can take suction from the settling tanks or service tank delivering to the service tanks or settling tanks. Circulation of settling tanks and service tank is available in case of heavy contamination.

Purifier 3 is a standard purifier and takes suction from either settling tanks or service tank delivering to the service tank only.

### Steam heating

The service tanks are equipped with steam heaters.

The temperature is controlled by P-controllers.

The temperature in the HFO service tank will normally be maintained at a temperature at 75°C.

All HFO supply and return lines are steam traced supplied from the steam reduction valve - refer to the FO service system.

### Miscellaneous

The HFO service tank has return pipes from venting tank, fuel oil service system, and boiler burner system and from the diesel generators.

The HFO service tank overflows to settling tank No.1

The MDO service tank has return pipe from the diesel generators and the oil fired boiler.

Overflow from the service tanks goes to MDO settling.

The service tanks are provided with drain valves and the drain are led to the Spill Oil tank.

The service tanks are provided with shut off valves (quick-release, remote controlled shut-off valves) at the tank outlet, which can be operated from the deck office in emergency situations.

The fuel quality within the tanks can be found on variable page 0530



**Operation procedure**

- Open the heating supply valve to the heating coils and set the desired temperature from the controller.
- HFO service tank temperature controller to be set at 60 – 80°C.
- DO service tank to be set at 35°C.
- Settling tank temperature to be set 5-10°C below.
- HFO requires temperatures minimum 30°C to be pumped.
- Drain water from tanks periodically.
- When switching tanks, always open inlet/outlet valves to "new" tanks before closing respectively on "old" tank.

<This page is intentionally left blank>

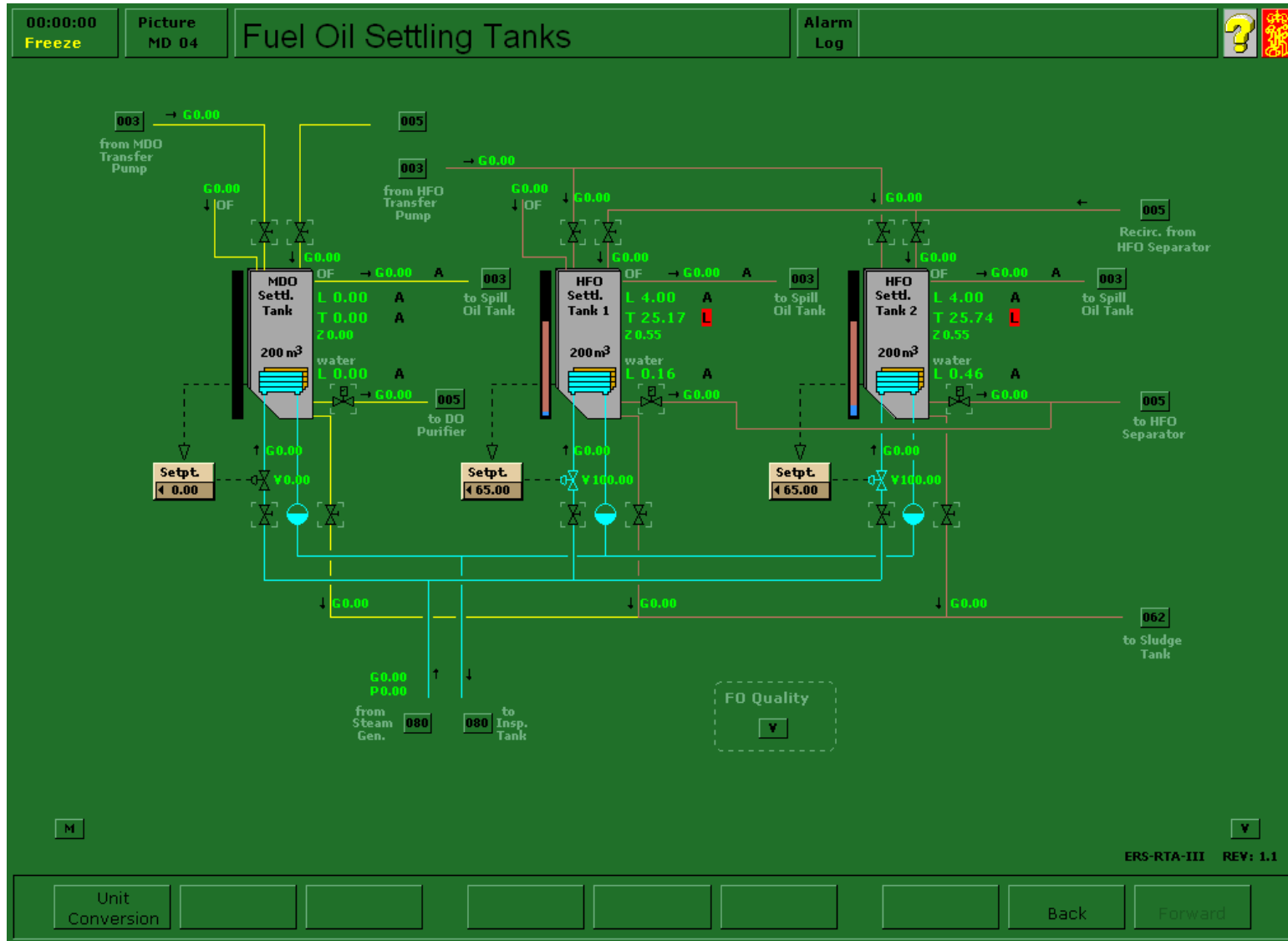



## 5.10 Fuel Oil Settling Tanks

### General

Fuel oil settling tanks comprise HFO Settling tank no. 1 and no. 2. and MDO Settling tank.

The purpose of the settling tanks is to:

- Settle bulk water and sludge.
- Act as buffer tank for the HFO purifier system.
- Supply the purifiers with fuel oil of an almost constant temperature.

### Description

The settling tanks are filled from the oil transfer system by the transfer pumps taking suction from either the bunker tanks or the fuel oil spill tank. The filling line at each settling tank is provided with a shut-off valve.

The purifiers take suction by means of shut-off valves (quick-release, remote controlled shut-off valves) at the outlet from each Settling tank.

Bulk water settled in the settling tanks can be drained from the bottom of the tank to the sludge tank via a drain valve.

### Steam heating

The temperature is controlled by P-controllers, positioning the steam control valves according to tank temperature and temperature set.

### Miscellaneous

Overflow from the settling tanks is led to the Spill Oil tank.

Each HFO settling tank has a return line with shut-off valve for excess oil from the HFO purifier feed pumps.

### Operation procedure

- 1 Open the heating supply valve to the heating coils and set the desired temperature from the controller.
- 2 Settling tank temperature to be set to a maximum of 5-10°C below flash point.
- 3 HFO requires temperatures at minimum 30°C to be pumped.
- 4 Drain water from tanks periodically.
- 5 If the temperature of the oil in the settling tank cools below a certain limit (40°C), it will be difficult for the purifier feed pump to transport the oil.

The quality of the fuel within the settling tanks can be found on variable page 0430.

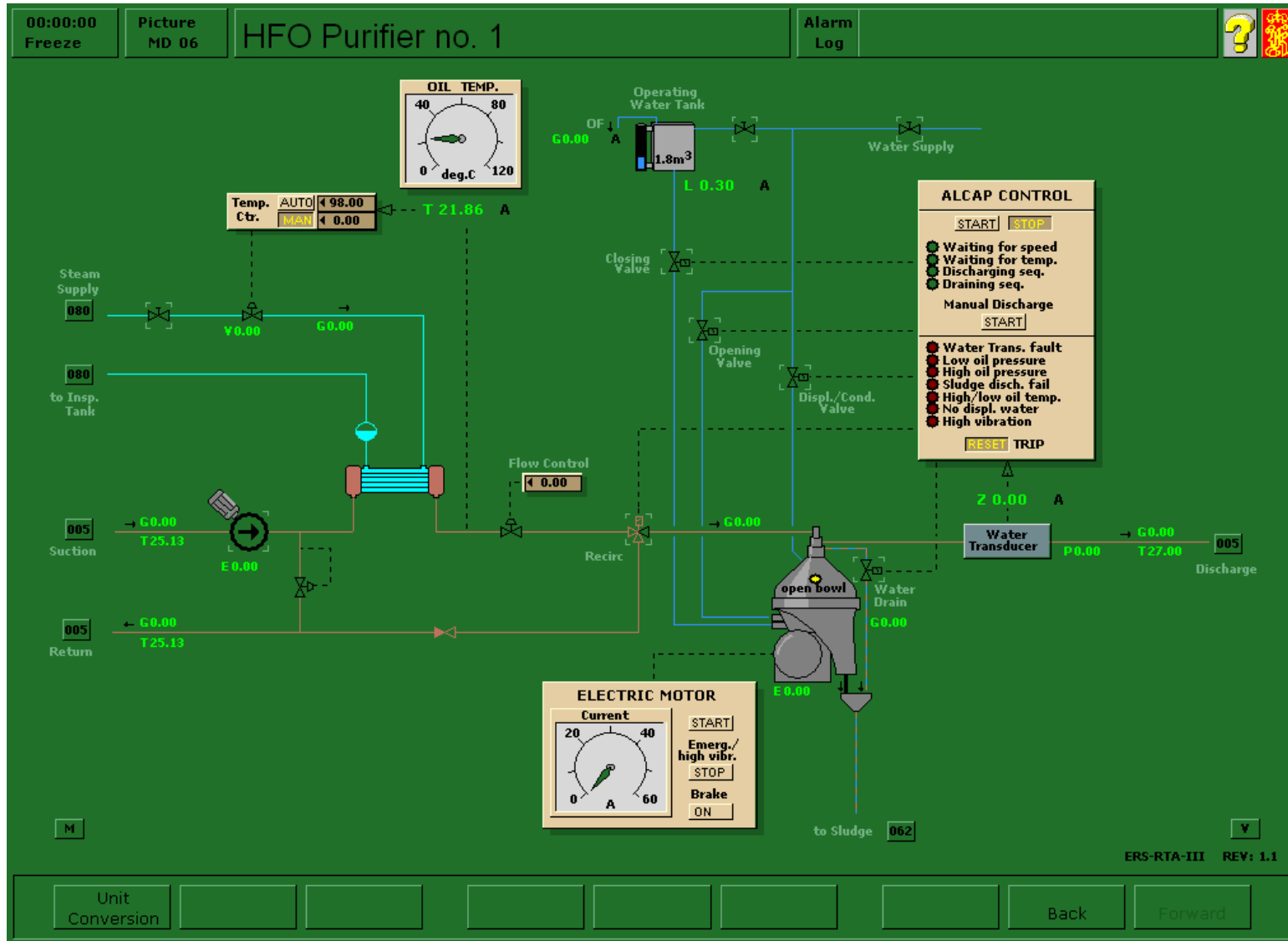



## 5.11 HFO Purifier System

### General

The purpose of the HFO purifier system is to supply the main engine and the diesel generators with fuel oil, free from impurities and water to the highest degree.

### Description

There are two HFO purifiers of the "ALCAP" type and one of the ordinary type MPOX. The HFO purifiers take suction from the settling tanks and the service tank and discharge to the HFO service tank.

### Operation Mode

#### Pumping up service tank:

The purifiers taking suction from the selected HFO settling tank and discharge to the HFO service tank.

#### Re-circulating service tank:

The purifiers takes suction from the HFO service tank and discharge to the HFO service tank.

Each purifier is provided with a separate electrically driven feed pump, the "ALCAP" system with constant displacement and the "MOPX" system with variable pump.

The flow to the purifier is controlled by means of an adjustable flow control valve or the variable pump. The excess flow from the feed pump is returned to the HFO settling tank or to the HFO service tank.

Each feed pump/purifier has a capacity, which is 10% above maximum total HFO consumption.

Each purifier is provided with an operation water gravity tank. During operation, there is a constant consumption of operating water and the operating water gravity tank must be manually refilled on low alarm.

The oily water sludge and the drain from the shooting are collected in the sludge tank.

A steam heated pre-heater heats the heavy fuel oil before it is led to the purifier bowl. A PID controller controlling a control valve at the pre-heater steam inlet controls the temperature.

Normally, operation is two HFO purifiers pumping up from the settling tank to the service tank.

If it is a very bad HFO the third purifier will circulate on the service tank.

### 5.11.1 HFO Purifier ALCAP no. 1+2

#### **Operating Principle:**

The oil to be cleaned is continuously fed to the purifier. Separated sludge and water accumulate at the periphery of the bowl.

Normally a sludge discharge takes place at specific time intervals, but if the water contamination is high, an earlier discharge may be initiated.



When separated water reaches the disk stack, some water escapes with the cleaned oil. The increase in water content is sensed by a water transducer installed in the clean oil outlet.

When the water content in the cleaned oil reaches a specific “trigger level”, the control program will initiate an automatic discharge of the water in the bowl. The water is discharged with the sludge through the sludge ports at the periphery of the bowl.

If the water contamination is so high that the “trigger” level is reached within 15 minutes (adjustable) after the last sludge discharge, the water drain opens. The valves remain open for a specific time after the water content has passed the “trigger” level on its way down.

If the water content in the cleaned oil does not decrease below the “trigger” level within 2 minutes after a sludge discharge or a water discharge through the water drain valve, there will be an alarm and the inlet oil valve will close.

On the ALCAP control panel there are indications of the following alarms:

- Water Transducer Failure
- Low Oil Pressure
- High Oil Pressure
- Sludge Discharge Failure
- High/Low Oil Temperature
- No Displ. Water
- High Vibration

Water transducer failure alarm is activated if the transducer is measuring less than 0.05% water content in the outlet oil. Since it is not possible to measure a water content below this value in this purifier system, this limit is used to indicate a fault condition of the transducer. This failure could be loose connections, faulty oscillator unit, etc.

After repair of transducer the ALCAP must be reset before it is possible to start the purifier.

High oil outlet pressure alarm is indicated when oil pressure out is more than 1.9 bar.

Low oil outlet pressure alarm is indicated when oil pressure out is less than 1.45 bar.

When the pressure has been adjusted the ALCAP has to be reset.

High/Low oil temperature alarm is activated if the oil temperature differs more than 5% from set-point.

When the oil temp is within 5% from set-point the ALCAP has to be reset.

No displ. water alarm is activated when the ALCAP control system tries to fill water but there is no water supply because the shut-off valve is closed.

When the water supply is opened the ALCAP has to be reset.

High vibration alarm is activated when there is high vibration in the purifier bowl. When this alarm is activated, the purifier will be



emptied, the ALCAP control system will be shut down, the oil will be recirculated (three-way valve will close against purifier) and the electrical motor will stop.

After repair attempt, the ALCAP has to be reset.

Sludge discharge failure alarm is activated if the purifier is not able to empty the purifier for water and sludge. The ALCAP control system will directly try a new sludge/discharge sequence. If the water transducer still measures too high water content in the oil, the purifier will be emptied, the ALCAP control system is shut down and the oil will be recirculated.

After repair attempt, the ALCAP has to be reset.

### Operation procedure

- Normally two HFO purifiers are in service, but one HFO purifier capacity is enough for full speed. The HFO purifiers take suction from one of the settling tanks and discharge to the service tank.
- The flow through the HFO purifier in service should always be adjusted according to the current HFO consumption in order to optimise the purification at all times.

#### 1. Preparation “ALCAP”

- 1.1 Open supply and return valves from selected HFO settling tank.
- 1.2 Open HFO SEP oil inlet valve to purifier.
- 1.3 Open HFO SEP oil outlet valves to HFO service tank.
- 1.4 Open HFO SEP HEATER STEAM shut off valve.
- 1.5 Open valve for displacement water.
- 1.6 Drain settling tank.

#### 2. Starting procedure “ALCAP”

- 2.1 Start HFO SEP feed pump. Adjust desired flow.
- 2.2 Set temperature controller to AUTO and adjust set point to 98°C.
- 2.3 Check that the purifier brake is not engaged.
- 2.4 Start electric motor of the purifier.
- 2.5 Wait for purifier speed to stabilise. Observe the ammeter and “waiting for speed” indication on ALCAP control panel.
- 2.6 Put the ALCAP control into operation by pressing the start button on the control panel.

When correct oil temperature is reached (observe indication on the ALCAP control panel), the three way valve will open for delivery to the purifier.

- 2.7 Observe and adjust flow after purifier.

#### 3. Stopping procedure “ALCAP”

- 3.1 Perform a manual discharge
- 3.2 When discharge sequence has finished, push the stop button on the ALCAP control panel.
- 3.3 Stop the purifier
- 3.4 Stop the feed pump
- 3.5 If high vibration occurs stop the purifier and engage the brake immediately.

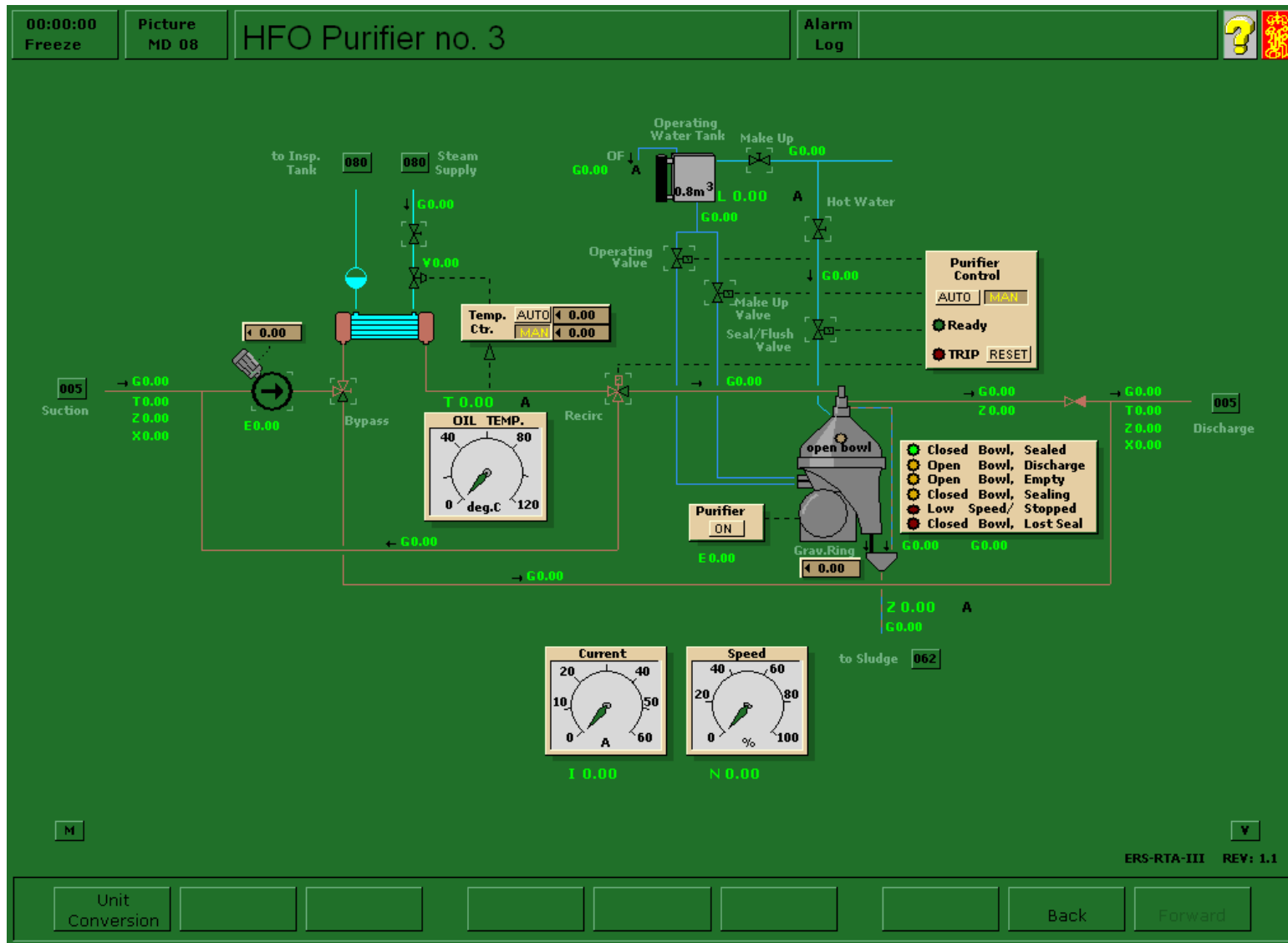



### 5.11.2 HFO Purifier MOPX no. 3

#### Description

There is one HFO purifier of the ordinary type MOPX operating after the same principle as the DO- and the LO purifiers.

The purifier takes suction from the HFO oil settling tank and discharge to the HFO service tank or circulating on the service tank.

The purifier is provided with a separate electrically driven displacement feed pump with adjustable speed.

By means of a 3-way changeover valve located before the pre-heater, the feed pump may discharge directly to the service tank, bypassing the purifier.

The purifier is provided with an operation water gravity tank. During operation, there is a constant consumption of operating water and the operating water gravity tank must be manually refilled on low alarm.

The oily water sludge and the drain from the shooting are collected in the sludge tank.

A steam-heated pre-heater may heat the diesel oil before it is led to the purifier bowl. The temperature is controlled by a PID controller controlling a control valve at the pre-heater steam inlet.

#### Normal operation:

- a) The purifier feed pump takes suction from the HFO settling tank and discharges to the HFO service tank via the purifier.
  - b) The purifier feed pump takes suction from the HFO service tank and recirculates to the HFO oil service tank via the purifier.
1. **Preparation**
    - 1.1 Open outlet valve from HFO settling tank. Open inlet valve to HFO service tanks.
    - 1.2 Start purifier feed pump. Adjust desired flow by using the variable delivery supply pump (when starting less than 20%).
    - 1.3 Set temperature controller in auto and adjust set point to 98°C. Start purifier by pushing the ON button.
    - 1.4 Fill operating water tank if necessary.
    - 1.5 Open make up water valve (Hot water for bowl content displacement).
    - 1.6 Set the gravity ring about 40 – 50 %.

#### Starting procedure

##### 2. MANUAL mode:

- 2.1 After purifier has reached full speed, and purifier controller is in manual, open make-up valve and wait until mimic reads BOWL CLOSED AND EMPTY.
- 2.2 Open seal/flush valve for 15 seconds to ensure proper water seal in bowl.
- 2.3 When mimic reads BOWL CLOSED AND SEALED, open oil flow to purifier by clicking open on three-way recirculation valve towards purifier. The supplied oil must have sufficient temperature.
- 2.4 Start purifying process with gravity ring less than 50% of full scale.



2.5 Adjust gravity ring to maximum value without losing water seal and adjust oil flow gradually to 100 %.

### 3. Ejection cycle:

- 3.1 Change the three-way valve to stop the flow of oil to the purifier.
- 3.2 After lost seal appears, open seal/flush valve for 5 seconds to empty bowl.
- 3.3 Close make-up valve.
- 3.4 Open operating valve for 5 seconds, mimic reads BOWL OPEN DESLUDGING and BOWL OPEN, EMPTY.
- 3.5 Close operating valve. Wait 15 seconds.
- 3.6 Open make-up valve.
- 3.7 When indicator reads BOWL CLOSED&EMPTY open seal/flush valve until mimic reads BOWL CLOSED AND SEALED.
- 3.8 When BOWL CLOSED AND SEALED appears, open re-circulation valve towards purifier.
- 3.9 When operating valves, indicating lamps must be observed to prevent rushing the procedure of starting cycle/ejection cycle.

### 4. AUTO mode

- 4.1 Press purifier on button, press start and switch to auto.

### 5. Re-purification of HFO service tank:

- 5.1 Open suction valve from HFO service tank.
- 5.2 Open discharge valve from purifier to HFO service tank.
- 5.3 Close purifier suction valve from HFO settling tanks.
- 5.4 Always open valves on HFO service tank before closing valve on HFO settling tank.

### 6. Adjusting gravity ring:

- 6.1 The efficiency of the purifier is dependent on the gravity ring setting and the feed flow. Low feed flow and large gravity ring result in better purification while small gravity ring increases the maximum flow admitted before broken water seal is likely to occur.
- 6.2 The cleaning must always be optimised according to the current flow through purifier.
- 6.3 The gravity ring is slowly maximised until oil is observed in the sludge flow.
- 6.4 When oil is observed in the sludge flow, decrease the gravity diameter a few percent until there is no oil in the sludge flow.

<This page is intentionally left blank>

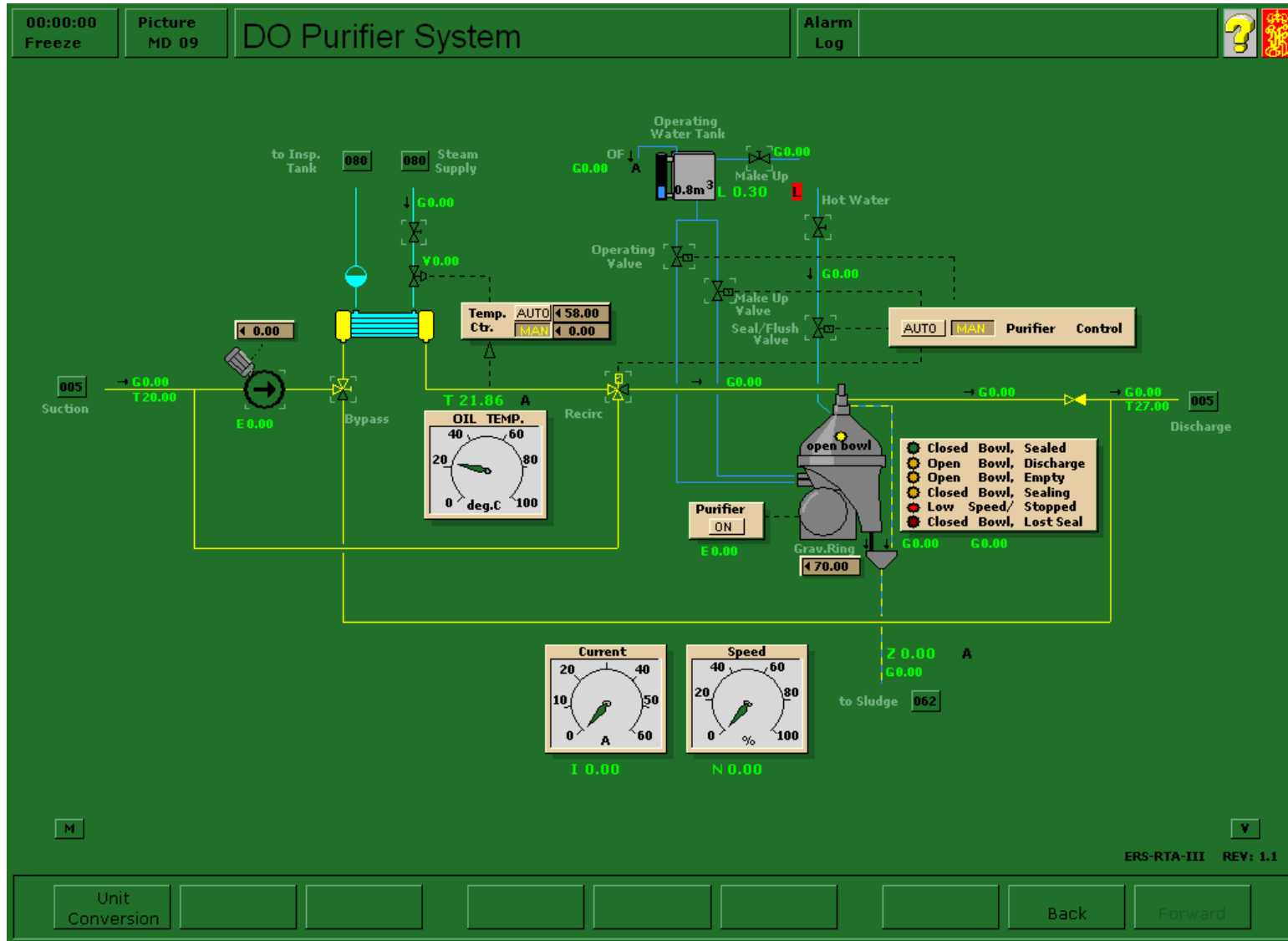



## 5.12 Diesel Oil Purifier System

### General

The purpose of the diesel oil purifier system is to supply the main engine and the diesel generators with diesel oil, free from impurities and water.

### Description

There is one diesel oil purifier. The diesel oil purifier takes suction from the diesel oil storage tank and discharges to the diesel oil service tank.

The purifier is provided with a separate electrically driven displacement feed pump with adjustable speed.

By means of a 3-way changeover valve located before the pre-heater, the feed pump may discharge directly to the service tank, bypassing the purifier.

The purifier is provided with an operation water gravity tank. During operation, there is a constant consumption of operating water and the operating water gravity tank must be manually refilled on low alarm.

The oily water sludge and the drain from the shooting are collected in the sludge tank.

A steam-heated pre-heater may heat the diesel oil before it is led to the purifier bowl. The temperature is controlled by a PID controller controlling a control valve at the pre-heater steam inlet.

### Operation procedure

#### Normal operation:

- c) The purifier feed pump takes suction from the diesel oil storage tank and discharges to the diesel oil service tank via the diesel oil purifier.
- d) The purifier feed pump takes suction from the diesel oil service tank and recirculates to the diesel oil service tank via the diesel oil purifier.

#### Emergency operation:

The purifier feed pump takes suction from the diesel oil storage tank and bypasses the purifier to the diesel oil service tank.

#### 1. Preparation

- 1.1 Open outlet valve from diesel oil storage tank. Open inlet valve to diesel oil service tanks.
- 1.2 Start purifiers feed pump. Adjust desired flow by using the variable delivery supply pump (when starting less than 20%).
- 1.3 Set temperature controller in auto and adjust set point to 60°C. Start purifier by pushing the ON button.
- 1.4 Fill operating water tank if necessary.
- 1.5 Open make up water valve (Hot water for bowl content displacement).
- 1.6 Set the gravity ring about 40 – 50%.



### Starting procedure

#### 2. MANUAL mode:

After purifier has reached full speed, and purifier controller is in manual, open make-up valve and wait until mimic reads BOWL CLOSED AND EMPTY.

- 2.1 Open seal/flush valve for 15 seconds to ensure proper water seal in bowl.
- 2.2 When mimic reads BOWL CLOSED AND SEALED, open oil flow to purifier by clicking open on three-way re-circulation valve towards purifier. The supplied oil must have sufficient temperature.
- 2.3 Start purifying process with gravity ring less than 50 % of full scale.
- 2.4 Adjust gravity ring to maximum value without losing water seal and adjust oil flow gradually to 100 %.

#### 3. Ejection cycle:

- 3.1 Change the three-way valve for stopping the flow to the purifier.
- 3.2 After lost seal appears, open seal/flush valve for 5 seconds to empty bowl.
- 3.3 Close make-up valve.
- 3.4 Open operating valve for 5 seconds, mimic reads BOWL OPEN DESLUDGING and BOWL OPEN, EMPTY.
- 3.5 Close operating valve. Wait 15 seconds.
- 3.6 Open make-up valve.
- 3.7 When indicator reads BOWL CLOSED&EMPTY open seal/flush valve until mimic reads BOWL CLOSED AND SEALED.

- 3.8 When BOWL CLOSED AND SEALED appears, open re-circulation valve towards purifier.
- 3.9 When operating valves, indicating lamps must be observed to prevent rushing the procedure of starting cycle/ejection cycle.

#### 4. AUTO mode

- 4.2 Press purifier on button, press start and switch to auto.

#### 5. Re-purification of diesel oil service tank:

- 5.1 Open suction valve from diesel oil service tank.
- 5.2 Open discharge valve from purifier to diesel oil service tank.
- 5.3 Close purifier suction valve from diesel oil settling tanks.
- 5.4 Close fuel oil discharge valve to diesel oil storage tank.
- 5.5 Always open valves on diesel oil service tank before closing valve on diesel oil storage tank.

#### 6. Adjusting gravity ring:

- 6.1 The efficiency of the purifier is dependent on the gravity ring setting and the feed flow. Low feed flow and large gravity ring result in better purification while small gravity ring increases the maximum flow admitted before broken water seal is likely to occur.
- 6.2 The cleaning must always be optimised according to the current flow through purifier.
- 6.3 The gravity ring is slowly maximised until oil is observed in the sludge flow.
- 6.4 When oil is observed in the sludge flow, decrease the gravity diameter a few percent until there is no oil in the sludge flow.



<This page is intentionally left blank>

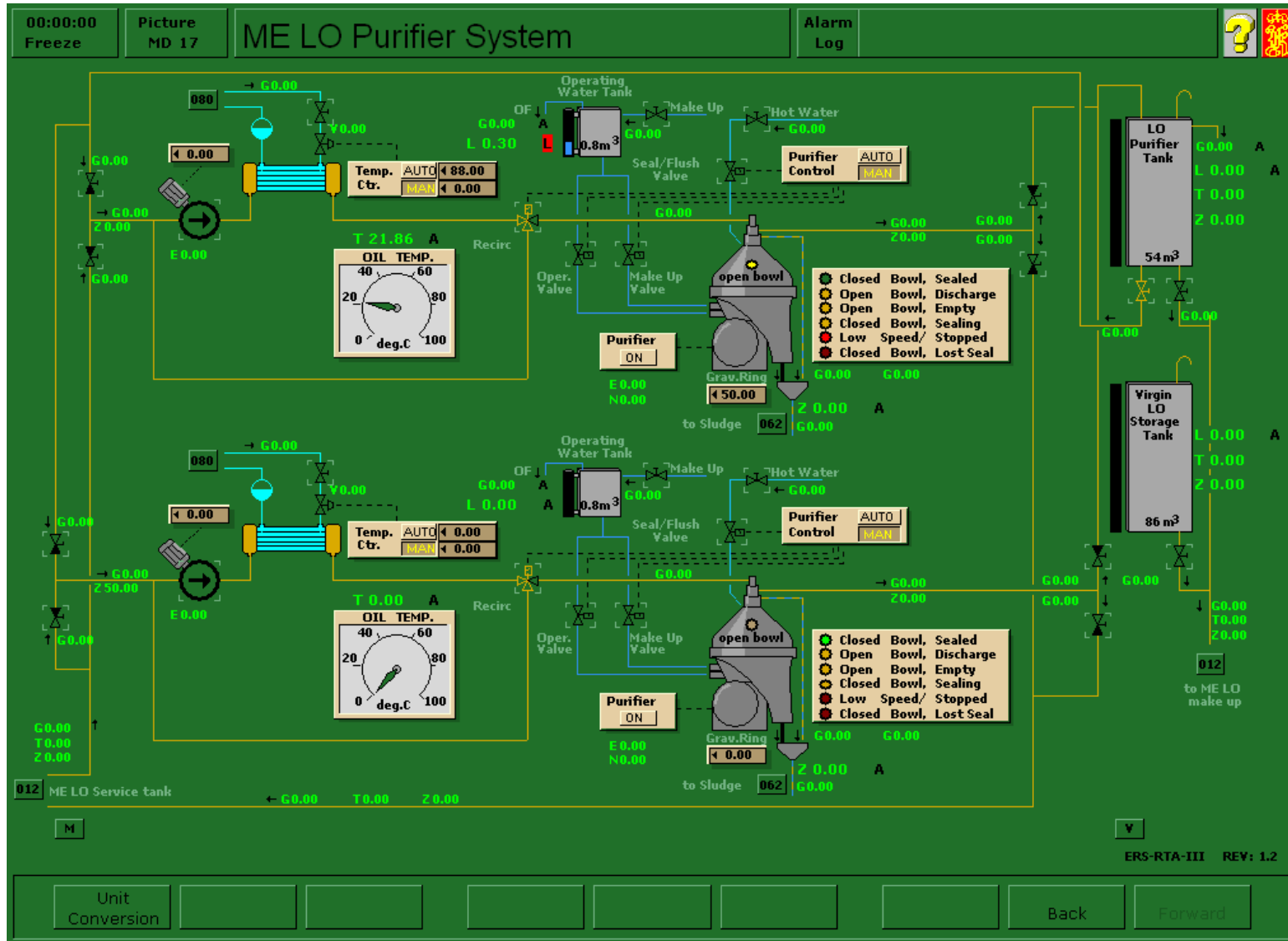

## 5.13 Lubrication Oil Purifier System

### General

- There are two lubricating oil purifiers
- One fresh oil storage tank
- One LO purifier tank
- The lubricating oil purifiers clean lubricating oil, taken from the ME LO service tank from the main engine and discharges it to back to the service tank.
- It is also possible to clean oil from the LO purifier tank by re-circulating,
- or to transfer oil from the ME LO service tank to the LO purifier tank because of engine trouble.

The purifiers are provided with a separate electrically driven displacement feed pump with adjustable speed.

The purifiers are provided with an operation water gravity tank. During operation there is a constant consumption of operating water and the operating water gravity tank must be manually refilled on low alarm.

The separated oily water and the drain from the bowl discharge are collected in the sludge tank.

A steam-heated pre-heater may heat the oil before it is led to the purifier bowls. The temperature is controlled by a PID controller controlling a control valve at the pre-heater steam inlet.

### Operation procedure

#### 1. Preparation

- 1.1 Prepare the purifiers for running depending of which systems to be cleaned.
- 1.2 Open outlet valve from selected lubrication oil tank.
- 1.3 Open inlet valve to selected lubrication oil tank.
- 1.4 Start purifiers feed pump. Adjust desired flow (when starting less than 20%).
- 1.5 Set temperature controller in auto and adjust set point to 85°C.
- 1.6 Start purifier by pushing the ON button.
- 1.7 Fill operating water tank if necessary.
- 1.8 Open make up water valve (hot water for bowl content displacement).

### Starting procedure

#### 2. MANUAL mode:

- 2.1 After purifier has reached full speed (5600), and purifier controller is in manual, open make-up valve and wait until mimic reads BOWL CLOSED AND EMPTY.
- 2.2 Start purifying process with gravity ring less than 20% of full scale. This can be changed when the purifier is running to allow optimisation of settings
- 2.3 Open seal/flush valve for 15 seconds to ensure proper water seal in bowl.
- 2.4 When mimic reads BOWL CLOSED AND SEALED, open oil flow to purifier by clicking open on three way re-circulation valve towards purifier. The supplied oil must have sufficient temperature.



2.5 Adjust gravity ring to maximum value without loosing water seal and adjust oil flow gradually to achieve optimum balance of cleaning and flow by monitoring oil dirt content.

### 3. Ejection cycle:

- 3.1 Close re-circulation valve by pointing to valve flange facing purifier and click the close button. (Right tracker ball button.)
- 3.2 After lost seal appears, open seal/flush valve for 5 seconds to empty bowl. Close make-up valve.
- 3.3 Open operating valve for 5 seconds, mimic reads BOWL OPEN DESLUDGING and BOWL OPEN, EMPTY.
- 3.4 Close operating valve. Wait 15 seconds. Open make-up valve.
- 3.5 When indicator reads BOWL CLOSED&EMPTY open seal/flush valve until mimic reads BOWL CLOSED AND SEALED.
- 3.6 When BOWL CLOSED AND SEALED appears, open re-circulation valve towards purifier.
- 3.7 When operating valves, indicating lamps must be observed to prevent rushing the procedure of starting cycle/ejection cycle.

### 4. AUTO mode

- 4.1 Press purifier on button, press purifier pump start and when purifier is up to speed switch purifier control to auto. Switching the purifier from auto to manual and back again initiates a sludge cycle.

### 5. Adjusting gravity ring

- 5.1 The efficiency of the purifier is dependent on the gravity ring setting and the feed flow. Low feed flow and large gravity ring result in better purification while small gravity ring increases the maximum flow admitted before broken water seal is likely to occur.
- 5.2 The cleaning must always be optimised according to the current flow through purifier.

**The gravity ring is slowly maximised until oil is observed in the sludge flow.**

- 5.3 When oil is observed in the sludge flow, decrease the gravity diameter a few percent until there is no oil in the sludge flow.

#### Note:

When cleaning oil in the LO purifier tank it is a must to take samples for analysing the efficiency of the purifiers.

<This page is intentionally left blank>

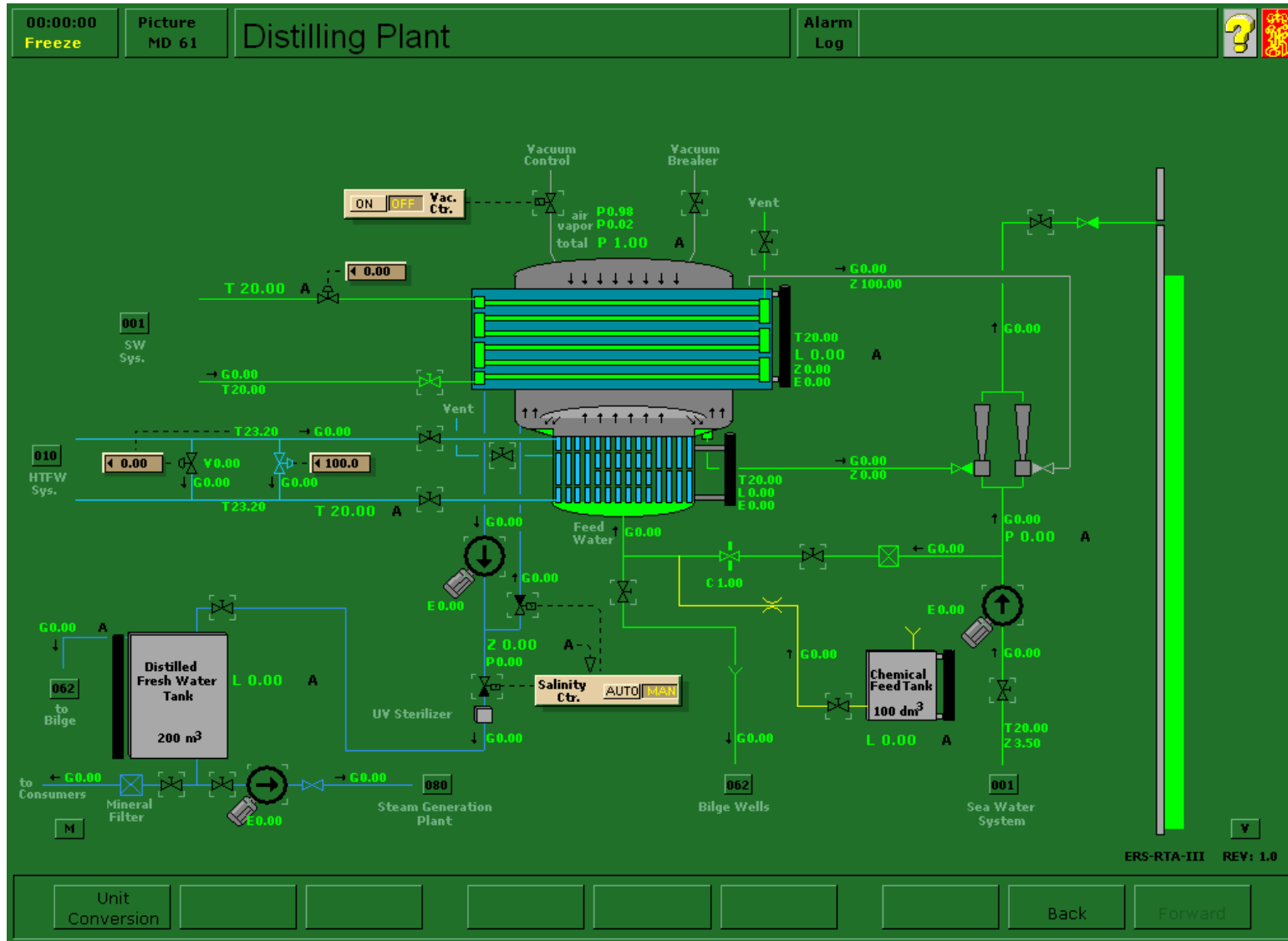



## 5.14 Fresh Water Generator

### General

Considerable waste heat sources may be utilised when connecting a fresh water generator to the main engine jacket cooling water system. Normally this temperature is 80 - 90°C.

The function is as follows:

A controlled amount of sea water is channelled via an adjustable orifice to the evaporator where it is heated by the HTFW. The fresh water generator operates under vacuum conditions in order to reduce the evaporation temperature. The vacuum, and thus the evaporation temperature, must be controlled to reduce the scale formation in the sea water side of the evaporator.

The vacuum allows utilisation of low temperature heating sources. The vapours generated pass through a fine mesh demister, to prevent salt water carryover, to the condenser.

The condenser is cooled by sea water so the vapour condenses into fresh water. The fresh water falls by gravity to the bottom of the condenser and is led to the suction of the fresh water pump.

The condition of the fresh water is monitored by a salinometer and if the salinity is high the condensate is recirculated to the evaporator.

### Description

The evaporator is made up by heat exchangers of the tubular type.

The evaporator heating is supplied from the main engine HTFW circuit by controlling a bypass valve. In parallel to this is a manual by-pass which ensures fresh water flow to the main engine cannot be shut off.

The ejector pump is supplied from the main sea water system.

The maximum evaporator capacity is 30 ton/24 hours at sea water temperature 32°C.

The distillate water is led to the distilled fresh water tank via an ultra violet sterilisation unit.

### Warning!

**Do not operate the plant in polluted water. Fresh water must not be produced from polluted water, as the produced water will be unsuitable for human consumption.**

### Operation procedure

#### 1. Preparation

- 1.1 Set salinity controller to MAN.
- 1.2 Close evaporator drain valve.
- 1.3 Close vacuum breaker valve.
- 1.4 Close vents on FW stack and condenser stack
- 1.5 Check that automatic fresh water by-pass valve is fully open and the manual valve is set at 50%
- 1.6 Check that fresh water inlet and outlet valves from main engine system to generator are closed.



- 1.7 Open the sea water inlet valve to the ejector pump.
- 1.8 Open sea water valve for condenser (V00674, MD01).
- 1.9 Open sea water overboard valve from ejectors.
- 2. Starting /stopping procedure:**
  - 2.1 Start ejector pump and check pressure and flow.
  - 2.2 Open sea water flow to condenser, adjusting valve, gradually to 100%.
  - 2.3 Open sea water feed valve to evaporator.
  - 2.4 Prepare and start the addition to the evaporator of the chemical to prevent scaling in the evaporator.
  - 2.5 Wait for the total pressure in the generator to drop to approximately 0.10 bar (1.5 psia).
  - 2.6 Open evaporator heating outlet shut off valve (to HTFW system).
  - 2.7 Vent the heating stack
  - 2.8 Open evaporator heating inlet shut off valve (from HTFW system).
  - 2.9 Close evaporator heating by-pass valve gradually while checking that the generator pressure does not exceed 0.1 bar.
  - 2.10 Activate the automatic vacuum control valve by pressing ON at Vacuum Ctr. panel.
  - 2.11 When distilled fresh water is visible in sight glass, open distillate re-circulation valve and start the distillate pump.
  - 2.12 When salinity control is below alarm limit, open the distilled water tank inlet valve and activate salinity control by pressing AUTO at Salinity Ctr. Panel.
  - 2.13 To **stop** the fresh water generator.
  - 2.14 Stop the distillate pump.
  - 2.15 Set the salinity control in manual.

- 2.16 Close the valve to the distilled fresh water tank.
- 2.17 Gradually open the bypass valve in the HT fresh water system.
- 2.18 Close the fresh water valves to the evaporator and allow to cool
- 2.19 Close the sea water feed valve to the evaporator.
- 2.20 Stop the ejector pump and closed valves in this circuit.
- 2.21 Open the vacuum breaker and set the vacuum controller on off.
- 2.22 Open the drain valve from the evaporator.
- 2.23 Stop the sea water to the condenser and closed valves in the circuit.
- 2.24 Close the valves to the chemical tank.

**Note:**

Chemical treatment is added to the sea water in order to minimize foaming in the evaporator and restrict the formation of salt water scale. It is essential that the correct dosage of chemical is used and frequent check must be made on the dosing unit to ensure that the correct treatment is being applied.

**Note:**

When stopping the fresh water generator it is important to check that the manual bypass valve is open before closing the valves to the evaporator, otherwise it can cause a shut down of the ME because the flow in the HT fresh water system is stopped. The manual valve will normally be set at 50% and left at this position.





## 5.15 Bilge System and Bilge Separator

### Pollution prevention

To reduce pollution of the world's coasts and waters by the shipping industry, extensive regulations and penalties have been established and are being enforced. Of greatest interest to the engineering officer are the regulations concerning the pumping of machinery space bilges. The law, as established by MARPOL 73/78 ANNEX I, for ships of 10,000 gross tons and above, defines permissible discharge of machinery space oily mixtures., as follows:

1. *No Discharge* is permitted, except when:
  1. The vessel is en-route outside port limits,
  2. the ship is operating an approved oil content monitor, oil separating or filtering device which will automatically alarm and stop discharging when the oil content of the effluent exceeds 15 parts per million (ppm), and
  3. the oil content of the effluent without dilution does not exceed 15 ppm and is not mixed with any cargo residues or chemicals

With reference to machinery space bilges all sea areas are treated as special areas unless stricter local controls exist such as Antarctica when zero discharge is allowed.

The MARPOL regulations are more restrictive for oil tankers cargo residues and these should be treated in their own right under appropriate MARPOL regulations.

ALWAYS REFER TO THE LATEST REGULATIONS AS AMENDED. THE REQUIREMENTS OF WHICH WILL BE INCLUDED IN YOUR SHIPS SAFETY MANAGEMENT SYSTEM AND STANDING ORDERS.

It is your responsibility as a marine engineer to know, understand, and obey the law.

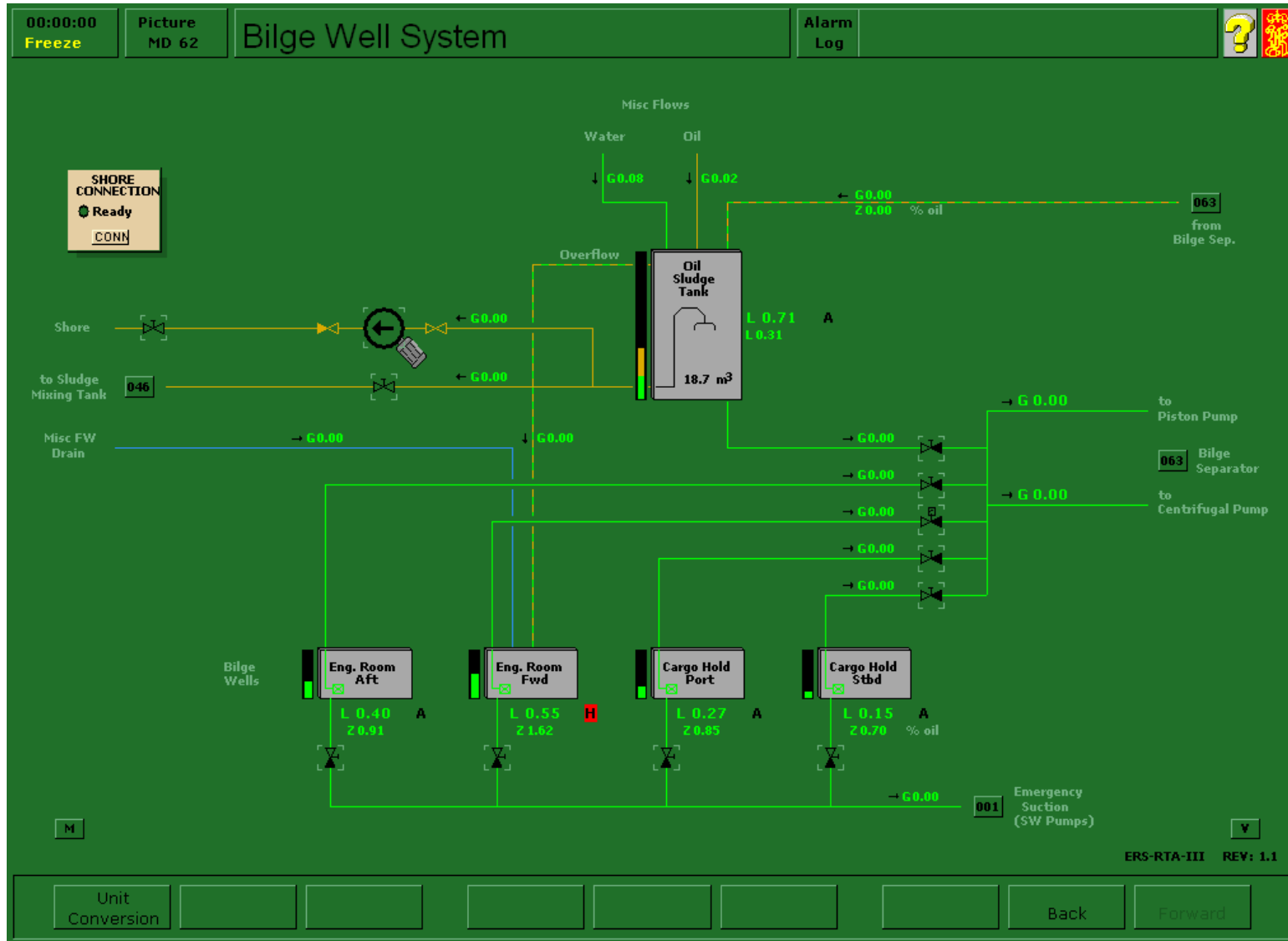



### 5.15.1 Bilge Wells

#### General

Bilge well description

The following bilge wells are included:

- Engine room aft
- Engine room forward
- Cargo hold port
- Cargo hold starboard

A small amount of oil and water is constantly leaking into the bilge wells (from unspecified sources). The engine room bilge well, in addition, receives possible overflow from the sludge tank and miscellaneous freshwater leakage/overflows from the engine room systems.

The bilge pumps can take suction from any of the four bilge wells, or from the sludge tank, and discharge it to the bilge separator.

There is a reciprocating pump for normally service use with the oily water separator. A centrifugal pump for pumping larger quantities of water direct to the bilge tank and an emergency bilge suction arrangement from the main SW centrifugal pumps for use when engine room flooding is occurring.

#### Sludge tank

The sludge tank receives drain from the following sources:

- HFO purifier sludge
- DO purifier sludge
- LO purifier sludge
- The settling tanks 1& 2

Oily return flow from the bilge water purifier also enters the sludge tank.

Sludge can be drawn from the sludge tank by the incinerator oil sludge pump and delivered to the sludge mixing tank. Otherwise sludge is discharged to a shore reception facility using the dedicated sludge pump. The suction from the sludge tank is taken from the top (oil) part of the sludge tank by means of a float device.

#### Pumping sludge water ashore

- Follow the onboard written procedure for pumping sludge ashore. It will be considered as a bunkering operation using the same onboard management systems. i.e. planning and check lists etc This will include
- Be aware of who is responsible for the job and inform the bridge.
- Connect the hose between the ship and the shore installation. (Press connect on shore connection panel)
- Prepare the emergency equipment as per S.O.P.E.P.
- Check the communication line.
- Open the valve after the sludge pump.
- Check the emergency stop of the pump with the watch man from the ship.
- Start the pumping and keep good communication with the watch man on the deck.
- Get the receipt from the sludge company when the job is finished.
- Complete all records i.e. log and oil record book.

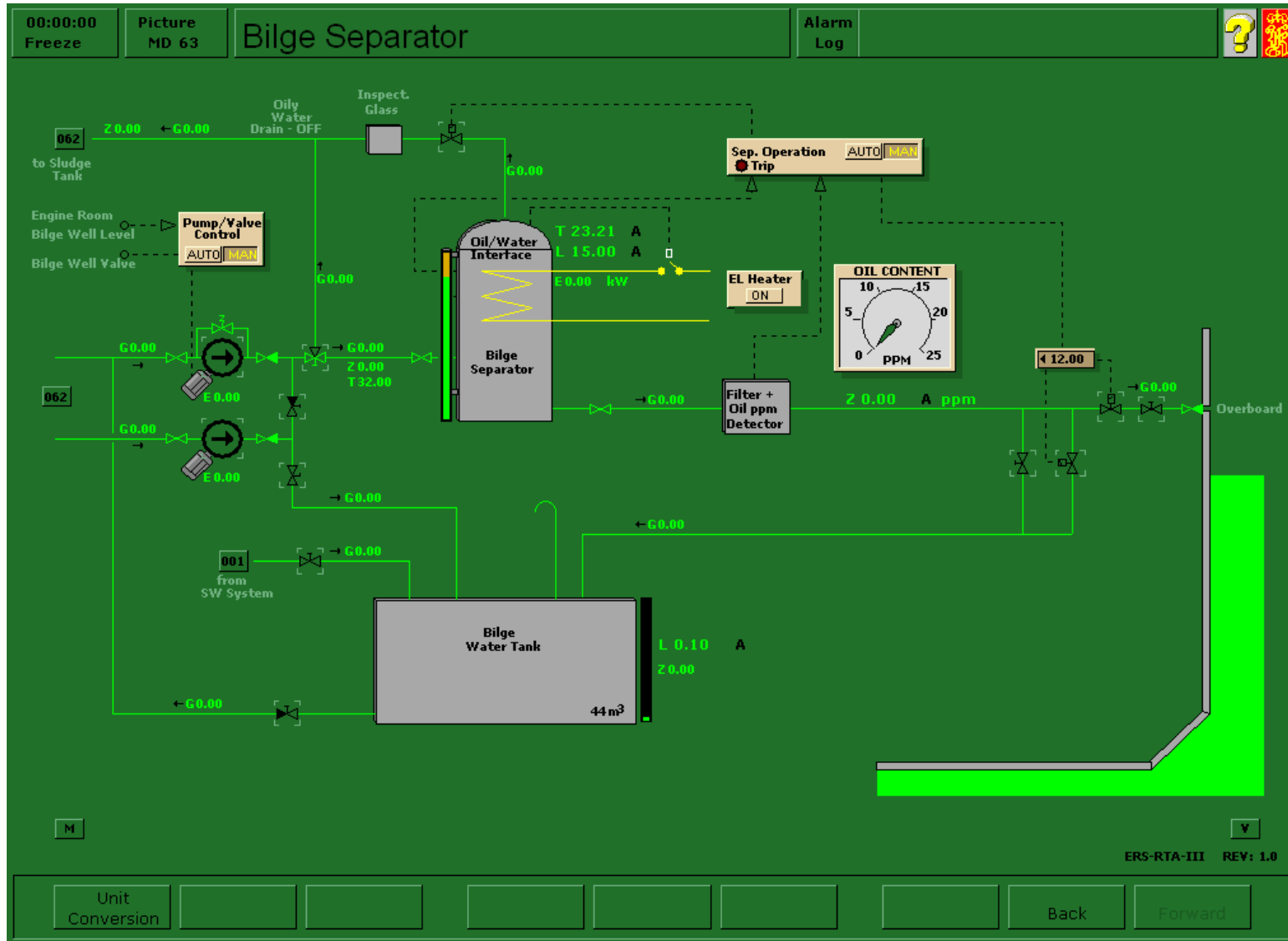



## 5.15.2 Bilge Separator

### General

The separator is provided to eliminate engine room bilge water in accordance with current pollution prevention regulations by discharging water containing no more than 15 ppm of oil overboard.

The bilge separator separates oily water taken from the bilge tank, sludge tank or from the bilge wells. Clean water is pumped overboard or to the clean water bilge tank, while the oil is returned to the sludge tank.

The separator unit consists of a tank divided into several zones by internal baffles. A positive displacement bilge pump pumps unprocessed oil/water through the separator which discharges clean water via the oil content monitor overboard or to the bilge tank. The reciprocating bilge pump can also be used to transfer high oil content waste to the sludge tank.

As the oil/water mixture flows through the tank, oil droplets are attracted to the coalescer beads while water is repelled under the influence of gravity and heat. Water passes around the beads but oil temporarily attaches to them. Oil droplets accumulate on the beads until they become large enough to break away and float to the top of the tank.

Meanwhile, the treated water is discharged from the bottom of the tank, through the oil content monitor and then either overboard or

to the Clean Bilge Tank, depending on residual oil content. Effluent will only be discharged overboard when its oil content is less than 15 ppm.

Eventually the oil layer at the top of the tank increases sufficiently to trip a sensor which causes the separator drain solenoid to open. The accumulated oil is forced out through the oil discharge valve to the sludge tank.

If the separator is operated in “AUTO” mode, the following functions are automatic:

- The overboard valve is closed and the re-circulation valve opened if the ppm limit in the overboard water is above a pre-set limit.
- If the oil/water interface sensor detects low level (much oil), the sludge valve is opened.
- The bilge separator pump may be started/stopped automatically according to the bilge well level. This function is dependent on suction from the engine room bilge well.

A flashing AUTO light indicates functional failure. The cause can be high oil content (low-low oil/water interface level) or low separator temperature. The separator pump will then be stopped, the sludge valve opened and the overboard and re-circulation valves closed.



The heating power is turned on/off according to temperature, by a thermostatic switch as long as the main switch is on. This switch works independently of the AUTO mode.

### Operation procedure

#### 1. Preparation of bilge separator

- 1.1 START electric heating of bilge separator and set separator operation in MANUAL.
- 1.2 Set the separator into AUTO mode when sufficient temperature (50°C).
- 1.3 Check the setting of the ppm detector.

#### 2. Automatic or manual operation of the separator

- 2.1 Normally the separator is operated in AUTO. In Auto the valves for bilge over board, bilge re-circulation to clean bilge tank and sludge drain from separator to sludge tank are automatic controlled.

#### 3. Manual bilge from engine rooms to clean bilge tank

- 3.1 Check oil content in bilge well.
- 3.2 Open suction valve from bilge well.
- 3.3 Open valves through separator.
- 3.4 Check that over board valve is closed.
- 3.5 Open discharge valve to the bilge water tank.
- 3.6 Check that bilge separator is in Auto.
- 3.7 Start bilge pump (piston) in manual.  
If bilge has high oil content open 3-way valve before bilge separator and discharge directly to sludge tank.
- 3.8 Let the oily water mixture separate in sludge tank before emptying water to clean bilge tank.

#### 4. Automatic bilge from engine room to clean bilge tank

- 4.1 Check that over board valve is closed.
- 4.2 If AUTO bilge control is active, the bilge suction valve from the engine bilge and the bilge pump will be activated according to the level in the bilge.
- 4.3 If the bilge pump is ON for more than 20% (adjustable) of the OFF time an alarm is activated. Immediate action must be taken.

#### 5. Emptying clean bilge tank over board

- 5.1 Check and write down time and ship's position.
- 5.2 Check that bilge separator is ready.
- 5.3 Open suction valve from clean bilge tank.
- 5.4 Open discharge over board.
- 5.5 Check that bilge separator is in Auto.
- 5.6 Start bilge pump.
- 5.7 Observe PPM-meter to ensure limits are being maintained.
- 5.8 Observe the bilge tank oil level and do not allow the pump to draw neat oil. This can be pumped at a later time directly to the sludge tank.
- 5.9 Check and write down time and ship's position when finished.
- 5.10 Complete the oil record book.

#### 6. Stopping Bilge Separator

- 6.1 Manually open Sludge valve to remove recovered oil.
- 6.2 Stop pump and close the bilge tank suction valve and overboard valves.

#### 7. Pumping sludge or bilge water ashore



---

Bilge water can be pump ashore through the oil sludge tank using the **procedure outlined in 5.15.1**

Oily mixtures are transferred to the sludge tank by changing over the 3 way valve on the separator inlet and using the reciprocating bilge pump to transfer the mixtures direct from bilges or from the bilge tank.

Larger quantities of water can be transferred using the centrifugal pump discharging via the non-return valve provided for this purpose.

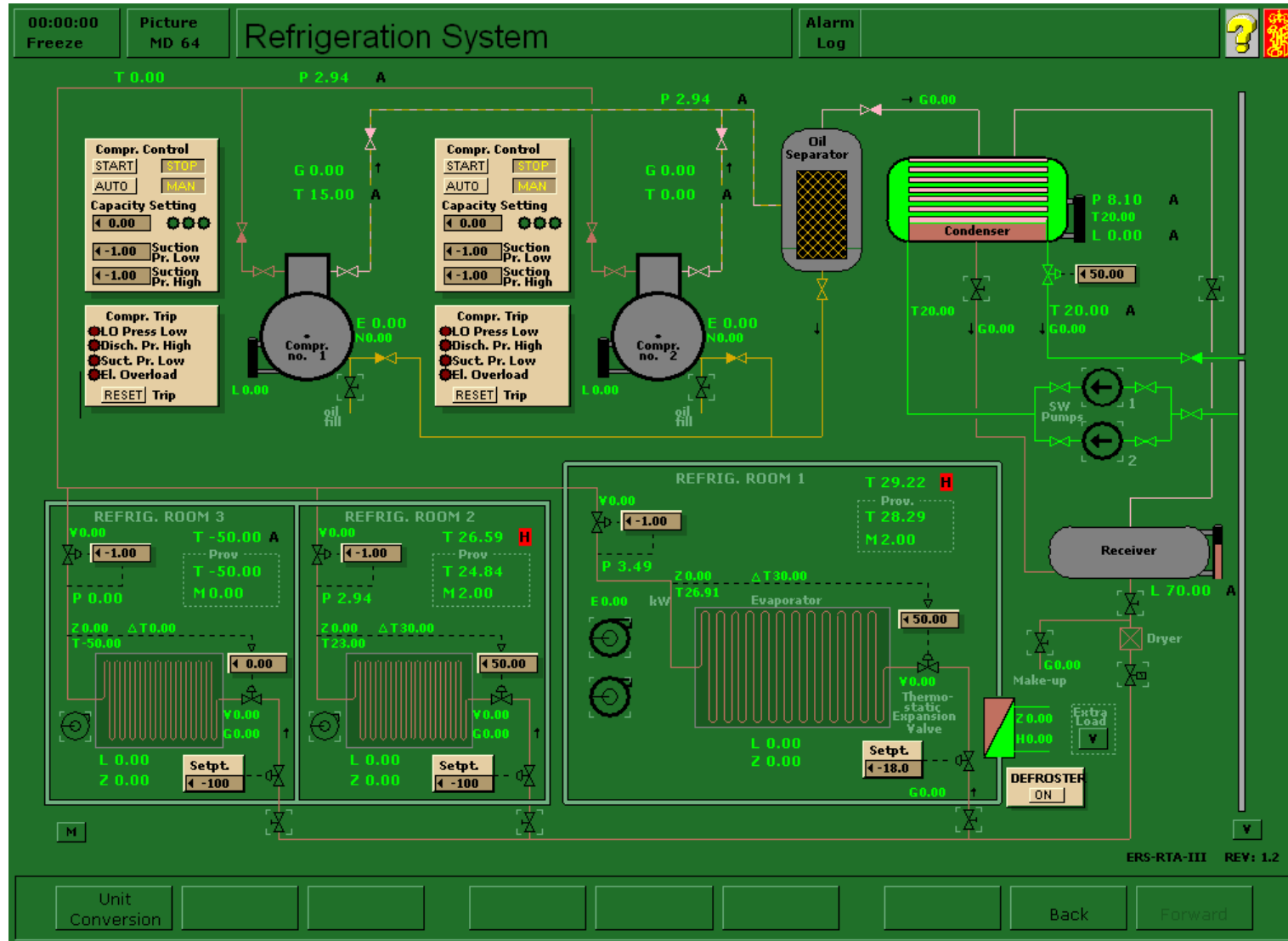





## 5.16 Refrigeration System

### General

The refrigeration plant is based on R22 and consists of the following main components:

- Electrically driven screw-type compressor (2 off)
- Compressor lubrication oil recovery system
- Sea water cooled condenser
- Refrigerant liquid receiver
- Three evaporators in three refrigeration rooms.

Nominal capacities are as follows:

Cooling capacity:	110 kW at - 18°C/30°C
Screw compressor motor:	50kW (67hp)
Refrigerant flow:	0.6 kg/sec
Sea water cooling flow:	20 t/h

The plant comprises following compartments:

### Room 1

Meat/Fish compartment (-18°C) including:

- One 4 kW air fan for cooling down
- One 1.5 kW air fan for normal operation
- One evaporator with dry expansion
- Evaporator electrical defrost device
- One evaporator back pressure controller.

### Room 2

Provision store compartment for perishable goods (+7°C) including:

- One air fan
- One evaporator with dry expansion
- One evaporator back pressure controller

### Room3

Provision store compartment for perishable goods (+4°C) including:

- One air fan
- One evaporator with dry expansion
- One evaporator back pressure controller

### Description

The compressors are lubricated and cooled by oil injection. The lubrication oil is separated from the compressed refrigerant gas in the oil separator. Oil from the bottom of the separator drains back to the compressor sumps which have level monitoring and filling arrangements.

A substantial part of the compressor heat is transferred to the cooling oil in the compressor screw, and the oil must be cooled. This is would be done by sea water in the lubricating oil cooler. (not shown)

The electric compressor motor load varies according to compressor condition, suction pressure, discharge pressure and gas flow.



Electric overload will occur if the load is higher than a pre-set adjustable limit.

The effective (internal) compression ratio and thus the compressor capacity of the screw compressor is adjusted by means of a suction slide valve.

The sea water flow to the condenser is supplied by two sea water pumps. Normally just one is in operation, while the other is stand-by. The sea water flow can be adjusted by a throttle valve at the condenser outlet. Normally 50% valve setting is used, giving a flow of approx. 20 ton/h.

The condensed refrigerant flows by gravity to the liquid receiver. The valve called "vapour valve" is for pressure equalising between condenser and the liquid receiver vessel. If it is closed, the draining of the condenser will be obstructed.

## Operation procedure

### 1. Preparation

- 1.1 Set room temperature and back pressure control settings to appropriate values. Ref saturation temps required.
- 1.2 Open vapour and liquid valves between condenser and receiver.
- 1.3 Open sea water cooling valves to the condenser and start sea water pump.
- 1.4 Condenser cooling water control valve must be set to a suitable level to maintain appropriate condensation pressure.
- 1.5 Check compressor oil levels and top up as required.

### 2. Starting

- 2.1 Start compartments fans.
- 2.2 Open the liquid valves from receiver to evaporators.
- 2.3 Reset the trip functions if any present and start the compressor.
- 2.4 Set compressor temperature control into MAN and adjust capacity control slide valve to 10%, (otherwise compressor will trip on overload). Start the compressor.
- 2.5 Gradually increase compressor capacity manually checking the compressor electric power consumption during cooling down.
- 2.6 Set compressor temperature controller into AUTO when temperature in Room 1 is below  $-10^{\circ}\text{C}$ .
- 2.7 Normal temperature in Room 1 is  $-20^{\circ}\text{C}$ .
- 2.8 When Room 1 temperature approaches  $-18^{\circ}\text{C}$  change to 1.5 kW fan.
- 2.9 Adjust Room 2 and 3's evaporator capacity regulator to the desired temperatures.

<This page is intentionally left blank>

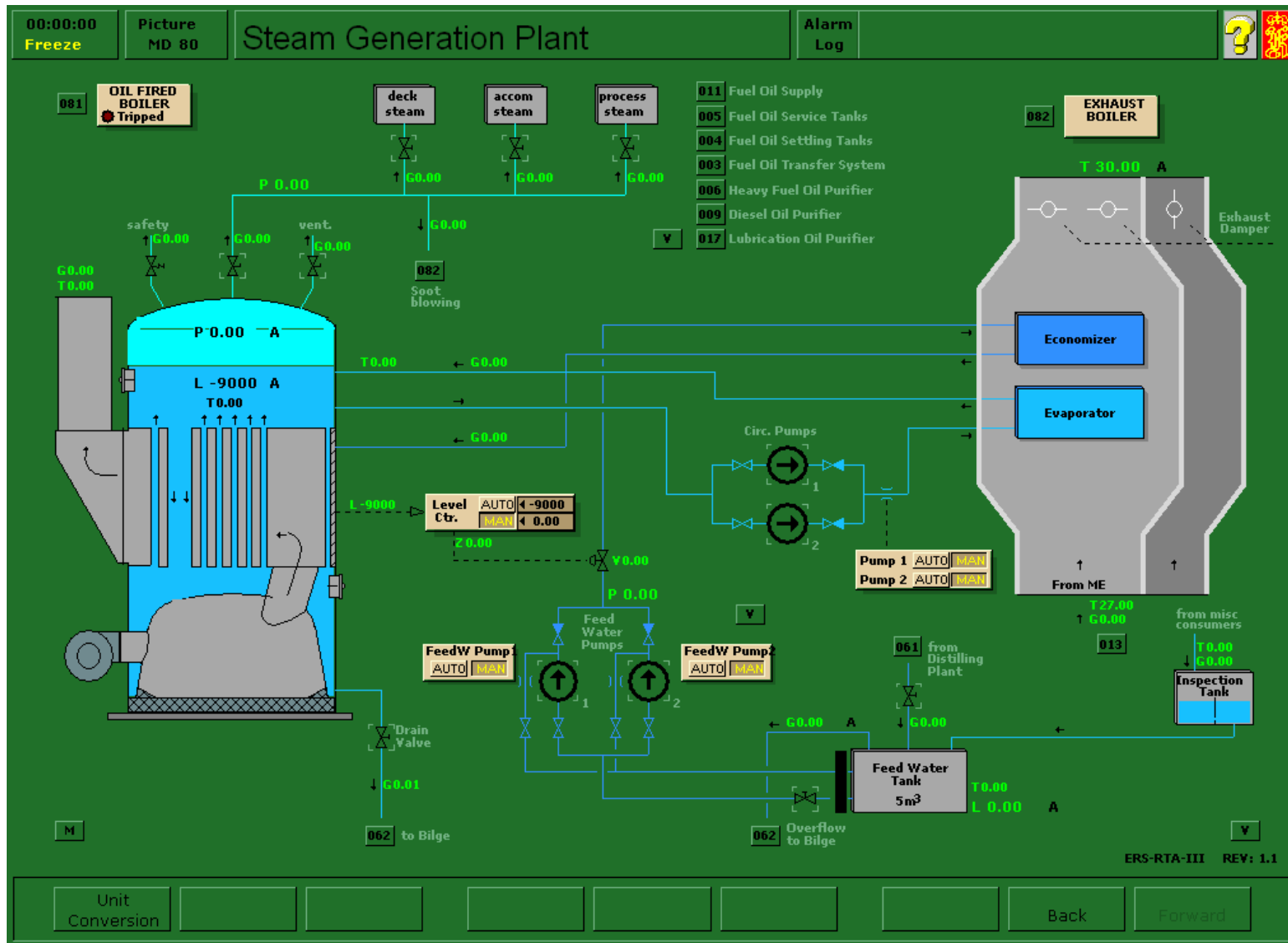



## 5.17 Steam Generation Plant

### General

The major components in the steam system are:

- Steam receiver / oil fired boiler
- Exhaust gas evaporator heat exchanger.
- Steam consumers
- Inspection tank
- Feed water tank
- Two feed water pumps
- Exhaust gas economiser feed heat exchanger.
- Two circulation pumps for the exhaust boiler
- Necessary valves/controllers

### Description

The oil fired boiler is a water tube boiler with a capacity of approx. 3.5 t/h at 7.0 bar for operation in port. The boiler can be operated on MDO or HFO manual or automatic.

The exhaust gas boiler has a capacity of approx. 11.0 t/h. for operation when the ME is running.

The oil fired boiler can be operated together with the exhaust boiler if it is necessary.

To control the steam pressure when the exhaust boiler is in operation, a separate steam pressure controller is included. It positions the damper according to need. When the steam load is low, more exhaust gas is by-passed and vices versa.

The oil burner is tripped at

- Flame out
- Low-low water level
- High-high water level
- High-high steam pressure

The water to the boiler is supplied from a feed water tank by two feed water pumps of which just one is normally running. A feed water valve and a PID level controller control the boiler water level.

Both feed water pumps trip at high-high water level to protect steam consumers from "water strike" caused by water in outgoing steam pipe. The boiler protection also includes a safety valve, which opens at high steam pressure.

A vent valve for use during start up heating and a water drain valve is also included. The steam condensate returning from the miscellaneous steam consumers is collected in the feed water tank. When necessary, more water can be added by the feed water make-up valve.

All condensate returns back to the Inspection tank.

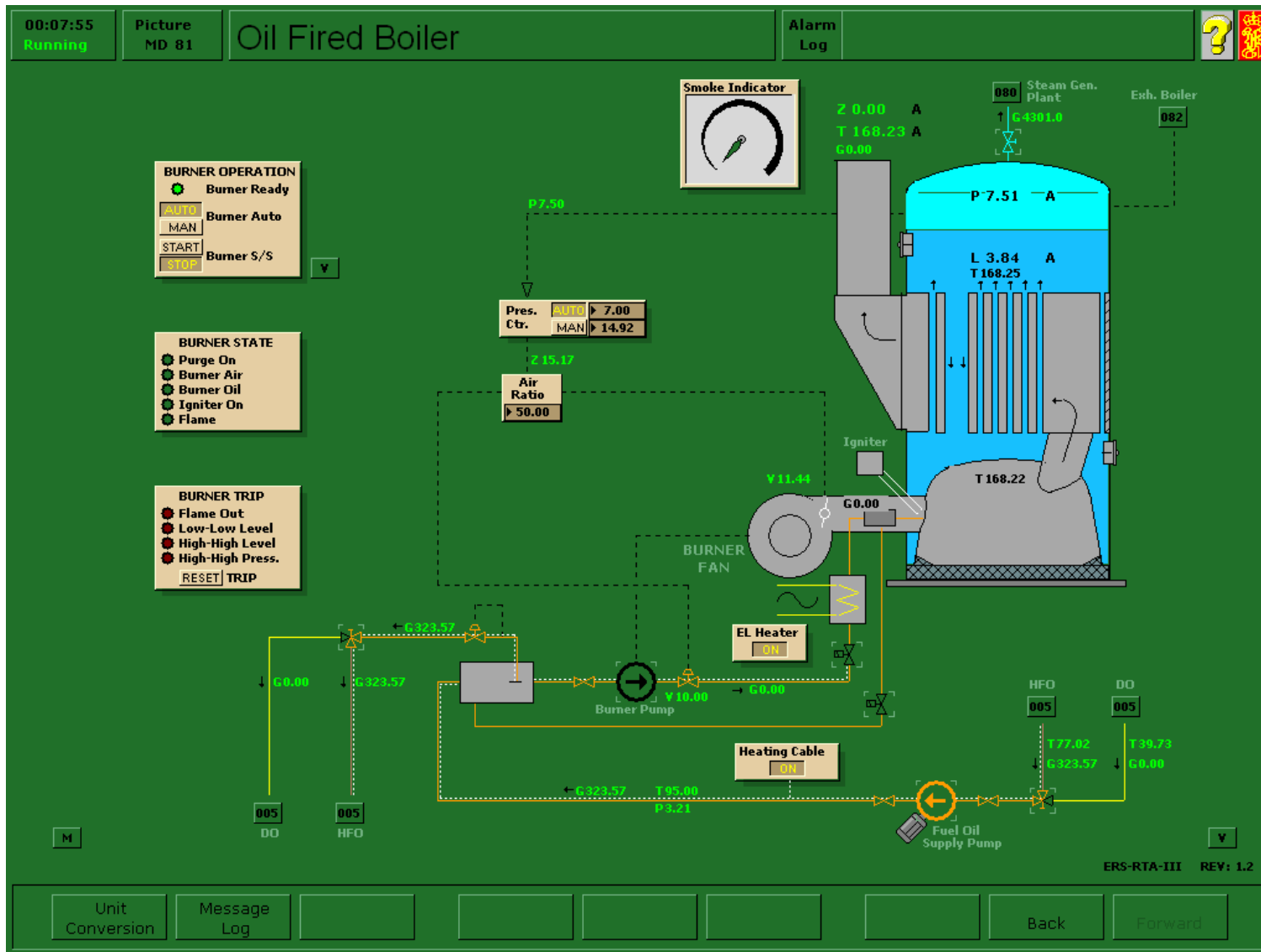



## Operation procedure oil fired boiler

### 1. Preparation

- 1.1 Select fuel oil service tanks.
- 1.2 Connect the heating cable.
- 1.3 Line up valves on fuel systems D.O. and start the fuel oil supply pump.
- 1.4 Open boiler drum air ventilation valve. Put level controller in manual mode.
- 1.5 Start one feed water pump and check the pressure and flow. Stop the first pump and start the other pump and fill up boiler drum to 10% below normal level. After filling stop the pump again.

## Starting procedure oil fired boiler

### 2. MANUAL mode

- 2.1 Observe the control panel and rectify any tripping faults.
- 2.2 High-high water level: Drain water by opening valve to bilge.  
Low-low water level: add water.
- 2.3 After rectifying faults, push the RESET button.
- 2.4 Set the pressure controller in manual mode with a set point on 5%.
- 2.5 Set the air ratio on 50%.
- 2.6 Start the burner in manual mode on the burner operation panel and check the burner state panel for the start sequence.
- 2.7 Check the smoke indicator.
- 2.8 Fire up the boiler slowly to reduce thermal strain by changing the set point on the pressure controller.
- 2.9 When the steam pressure is rising to about 1 – 2 bars pressure then close the vent valve.

- 2.10 When pressure rises to normal level, set feed water controller in auto and start the feed water pump.
- 2.11 Set up H.O. system and change to HFO.
- 2.12 Slowly open steam outlet valve and steam to consumers.
- 2.13 Set the pressure controller in auto mode.
- 2.14 Check the level, pressure, smoke indicator.

### 3. AUTO mode

- 3.1 Level controller to be set in auto mode (the feed water pumps are attached to this function).
- 3.2 Put the Boiler into AUTO from the burner control panel.
- 3.3 Burner will start and stop automatically depending on steam consumption.

The feed water tank is to be manually filled from the fresh water storage tank.

#### **Note:**

Firing the boiler from cold condition to full steam pressure 7 bar, must take 1½ hour (manufacturer demand).

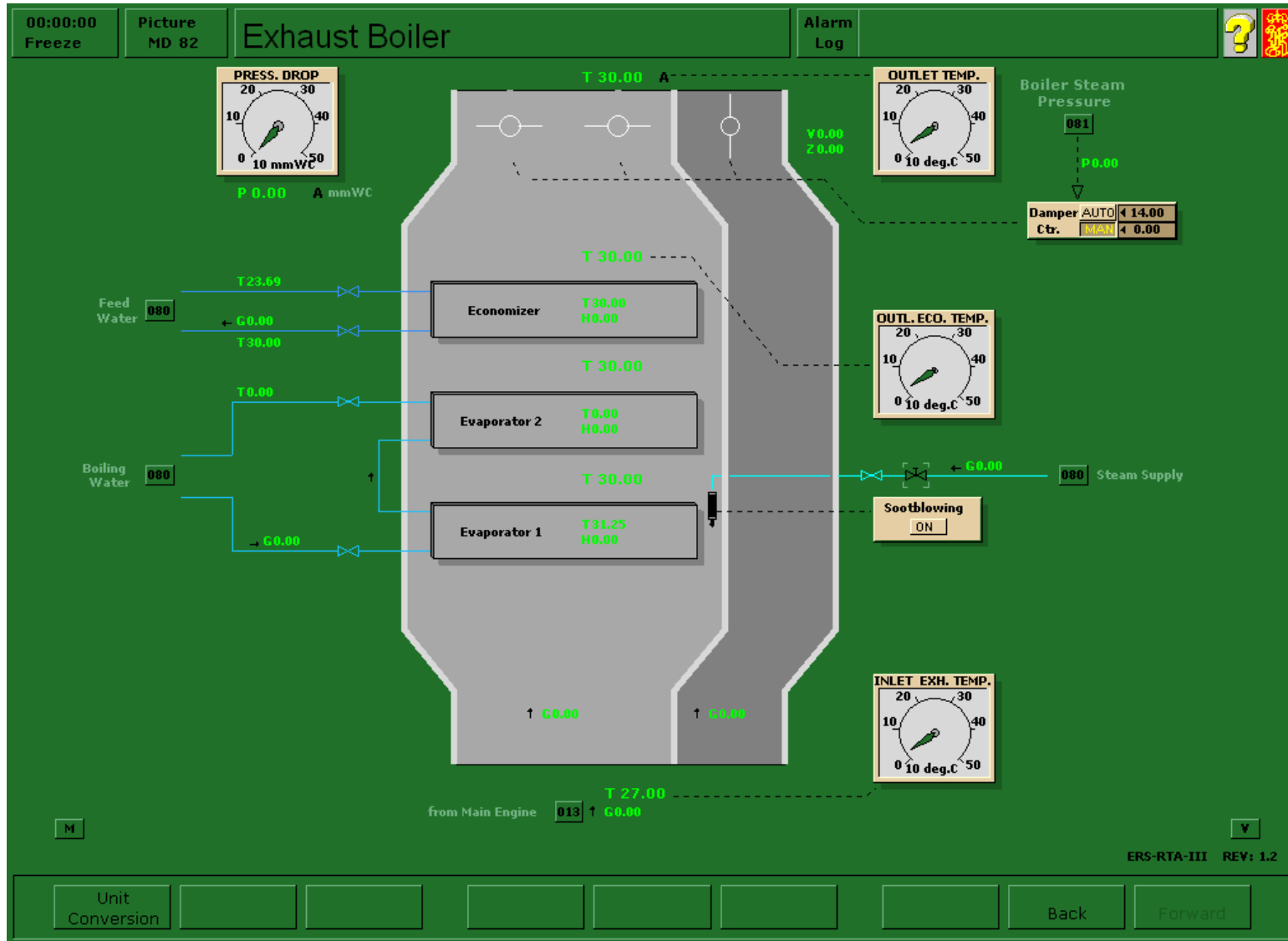





## 5.17.1 Exhaust Boiler

### General

The Exhaust Gas Boiler consists of two ducts through which the exhaust gases from the main engine pass. One duct contains four banks of heat exchanger tubes, the other is plain to bypass the heat exchangers. Dampers control of the exhaust gas flow path, and the damper position is regulating by the PID controller from a steam pressure input.

The top bank of tubes is the economiser section where the feed water passes through the tubes counter to the gas flow.

The next two banks are the evaporation section and the water from the oil fired boiler water drum is pumped by the circulation pump and enters the lower header of the lower bank and passes parallel to the gas flow collecting heat. The steam/water emulsion leaves via the upper header of the upper bank and returns to the steam drum of the oil fired boiler.

There is a steam soot blower fitted for cleaning the exhaust tubes.

### Operation

The Economiser section will be put into operation once the oil fired boiler main feed system is in use. I.e. all feed water passes through the economiser.

The Evaporator section is started up before stand-by engines and after the oil fired boiler feed system is in use by:

1. Starting one of the two circulating pumps.
2. Place the circulating pumps on auto to provide standby operation.

The economiser will normally remain fully by-passed during manoeuvring conditions and one under way the damper control changed over to auto.

### Caution:

In order to prevent damage of the exhaust gas boiler by eventual soot fire, the circulating pumps should always be kept in continuous service – also during stay in port. If shutting down wait 12 hrs before stopping the pumps.

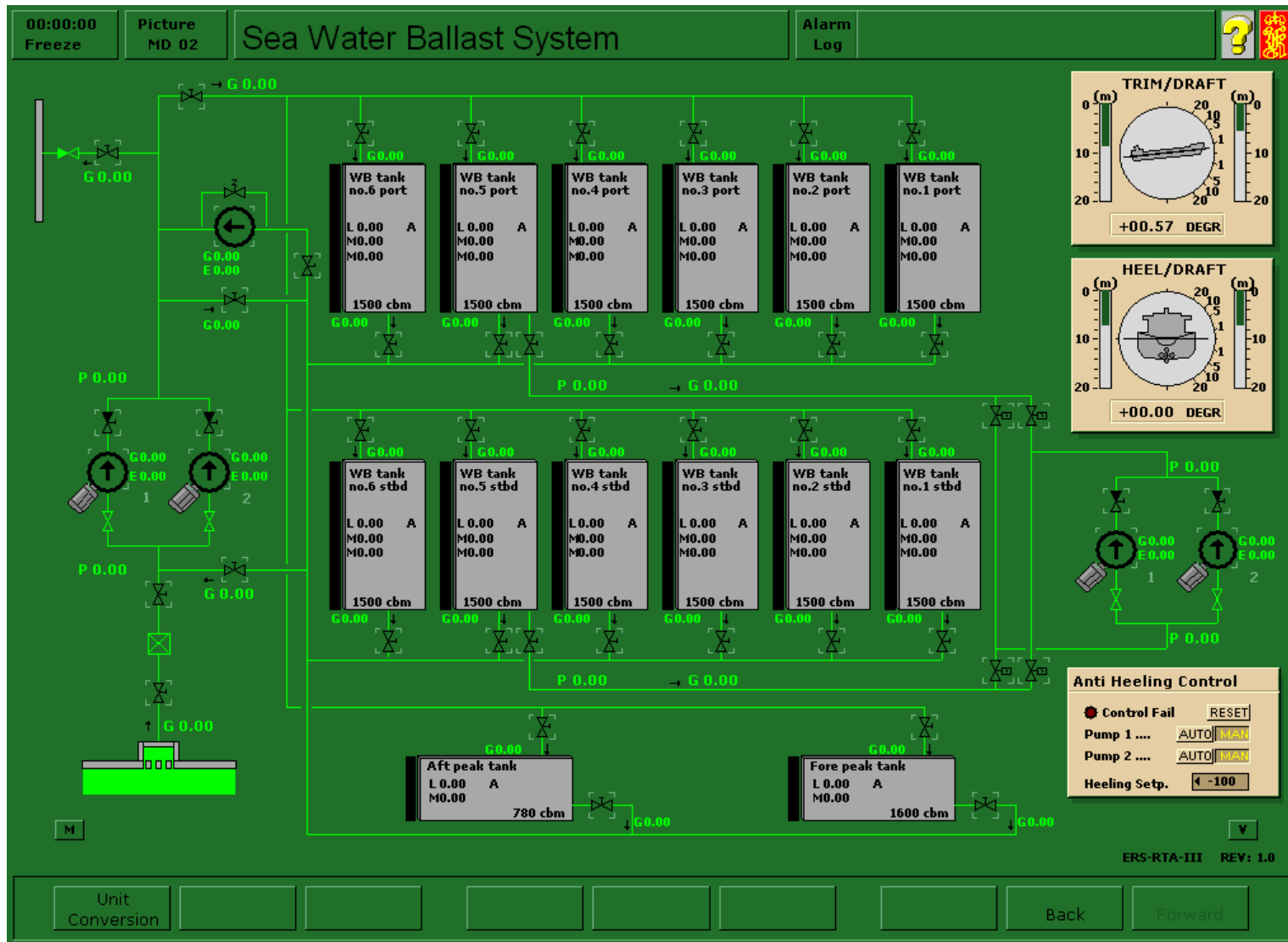



## 5.18 Sea Water Ballast System

### General:

The purpose with the ballast system is to continue a safe stability (trim/ heeling/draft) for the ship in any condition.

The ballast system consists of the following:

- Water ballast pump 1
- Water ballast pump 2
- Water ballast pump 3 (piston pump)
- Two heeling pumps
- Six wing ballast tank port, each volume 1500 m<sup>3</sup>
- Six wing ballast tanks starboard, each volume 1500 m<sup>3</sup>
- One after peak tank 780 m<sup>3</sup>
- One fore peak tank 1600 m<sup>3</sup>
- An anti heeling control panel

Wing ballast tank no. 5 port and stbd can be used as heeling tanks.

The heeling system can be operated in manual or auto mode.

### BALLAST OPERATIONS

Ballast water must only be pumped into ballast tanks or out of ballast tanks when full consideration has been given to the effect of transfer on the trim, draught, stability and stresses of the ship. No more than one single tank, or one pair of tanks, should be in the partly filled (slack) condition simultaneously.

Local regulations must be taken into account before discharging ballast water and any restrictions on the discharge of ballast water must be strictly observed.

All ballast and deballasting operations for each tank must be entered into the ballast log record book, form ID 207Q, stating

date, ship's position, temperature, specific gravity, pumped quantity, tank quantity and any further remarks. Additionally the IMO Ballast Water Reporting Form, ID 208Q must be filled in.

### Procedure for Setting Up for Ballasting

The chief officer is responsible for the ballast system in cooperation with the chief engineer.

Filling ballast tanks.

- a) Ensure that all suction strainers are clear.
- b) Ensure that all the pressure gauge and instrumentation valves are open and that the instrumentation is reading correctly.
- c) Open the required hydraulically operated remote control ballast valves.

### WARNING

**Under no circumstances must both ballast pumps be used to fill a single tank due to possible over pressurisation of the tank. The ballast tanks must NOT be over filled, as this can lead to ballast water entering the cargo holds and flooding the space via the open ventilation covers.**

(Note: Under normal circumstances no more than one pair of ballast tanks (port and starboard) should be partly filled at any one time in order to prevent stability problems due to the effect of slack tanks. Tanks not currently being filled or emptied should be either completely full or empty.)

- e) When the ballasting operations are complete, shut down the pumps and close all system valves.
- e) Fill in the ballast log record sheet.



### ANTI-HEELING SYSTEM

The anti-heeling tanks are located on the port and starboard sides of the ship and are No.5 side water ballast tanks.

The heeling tanks are filled and emptied as part of the ballast system.

The heeling system consists of two pumps located in a pipe joining the two heeling tanks.

There are four valves opening and closing in response to the control system, opening when the pump operates to move water from one tank to the other and closing when water has been transferred so that water cannot flow between tanks by means of gravity.

The valve closes gradually in order to prevent water hammer.

The valve is closed when the system is not operating. The pump is started and stopped from the system control panels, either in the ECR or on the bridge.

The maximum allowed level in any tank during heeling operations is 14.80 m and the minimum level at which the pump will automatically cut out is 0.3 m.

High level floats are fitted in each tank, these are connected to the alarm and monitoring system. A low level transmitter is fitted in each tank which stops the pump if the low level is reached. If the heel of the ship exceeds 6° when the pump is in operation, the system automatically shuts down.

### CAUTION

**If a heeling tank is ballasted to full capacity, the overflow can enter the cargo hold via the open ventilation covers.**

The anti-heeling system enables the vessel to remain in the upright position during cargo loading and discharge operations. In order to ensure that containers move freely in the cell guides, the vessel should be in the upright position but the loading and discharge of containers can result in a slight port or starboard list. Correction of the list is achieved by moving a quantity of water from the port to the starboard anti-heeling tank, or vice versa.

Operation of the system may be set to manual or automatic. When set to manual, operation the pump is controlled as required but in automatic mode the pump is completely under the control of the anti-heeling system. The pumping system operates in response to a sensor, which detects any change in the ship from the upright position. The heel detector unit is located on a mounting plate, which is fitted athwart ships on the ship's centre line. The signal from this is transferred to the anti-heeling control system and this responds by operating the pump to transfer water between the anti-heeling tanks in order to correct the list. An indicator panel is fitted on the bridge.

The pump cut-in and cut-out angles of heel are set in the alarm and monitoring control display. The start angle is normally set at 0.05° and the stop angle at 0.02°. If the start angle is made less, the frequency of pump operation will increase and that can be detrimental to the system.

A microprocessor based on programmable logic control system controls the anti-heeling system and allows for adjustment of angles and the valve closing time.



**CAUTION**

**It is essential that only authorised personnel with a knowledge of the system and an understanding of ship stability make any adjustment to the anti-heeling system. Errors in adjustment can have serious implications on the vessel's stability and operational performance.**

**CAUTION**

**Operation of the anti-heeling system is only permitted in harbour.**

**Procedure for Operating the Anti-Heeling System in Automatic**



- a) Ensure that the anti-heeling tanks are filled with sea water to the correct level.
- b) Ensure that there is electrical power at the pump and the anti-heeling system control panel and system devices. Ensure that the local control panel is set to AUTO for one pump.
- c) The anti-heeling system will operate automatically detecting any changes from the upright position and operating the pump and automatic valve to direct water between the heeling tanks in order to correct the heel.

00:02:43  
Running

Picture  
MD 57

## Ship Loading

Alarm  
Log

Aft Load

M 6420.0  
M 6420.0

Midship Load

M 9630.0  
M 9630.0

Forward Load

M 6420.0  
M 6420.0

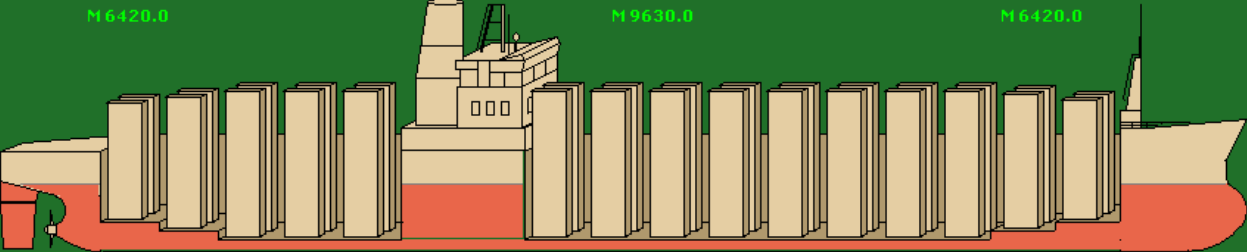

Containers	Target	Rate
▶300.0	▶300.0	▶30.0
▶300.0	▶300.0	▶30.0



Containers	Target	Rate
▶450.0	▶450.0	▶40.0
▶450.0	▶450.0	▶40.0

Containers	Target	Rate
▶300.0	▶300.0	▶25.0
▶300.0	▶300.0	▶25.0

Aft: max 600 Units

Midship: max 900 Units

Forward: max 600 Units

CONTAINER LOADING / UNLOADING

HEEL/DRAFT

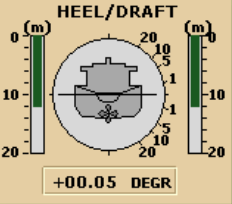

+00.05 DEGR

TRIM/DRAFT

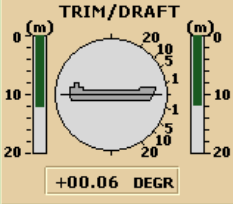

+00.06 DEGR

M

V

ERS-RTA-III REV: 1.1

Unit Conversion

Message Log

Back

Forward

## 5.19 Ship Load

### General

The container load of the vessel can be changed using Ship Load.

Containers may be loaded or discharges from Port and/or Stbd in the forward, midship and aft sections of the vessel.

Maximum container load is 2100 units.

In order to load or discharge containers the vessel must be in port.

To load or discharge the vessel input the target number of containers and the rate. Turn on container loading / unloading.

During cargo operations the heeling system should be in operation and loading adjusted to ensure that the vessel trim and list do not become excessive. Care must also be taken to prevent high sheer stress in the hull due to uneven loading.

00:38:56  
Running
Picture MD 104

## Auto Chief - Main Engine Control

Alarm Log 1

**RPM Command**

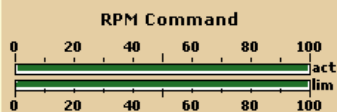

Decr Incr

**Fuel Link Command**

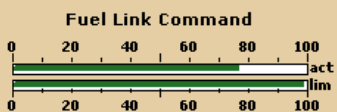

Scav Air Limit Torque Limit

**Chief RPM Limit**

102.0 (rpm)

Limit ▶102.0

Finish with Engine

ECR Stand By

At Sea

Responsibility Transfer

Local

Engine Ctr. R

Bridge

ME rpm 101.9

ME rpm Com. 102.0

**Rev. Counter**

005279

CPP

v

Max AHD	100
Full	80
Half	60
Slow	40
Dead Slow	20
Stop	0
Dead Slow	20
Slow	40
Half	60
Full	80
Max AST	100

Lever Align

Control Lever ▶ 100.0 Ready

Sea Mode

Maneu Mode

VIT

VEC v

Emerg Stop

Slow Turn

Cyl Pre-lube v

Shut Down

Slow Down

Fail

<input type="radio"/> LO Pressure	<input type="radio"/> LO Pressure	<input type="radio"/> Start F
<input type="radio"/> Cyl Cool P	<input type="radio"/> Cyl Cool P/T	<input type="radio"/> Rev Fail
<input type="radio"/> Pist Cool F	<input type="radio"/> Pist Cool T	<input type="radio"/> Brake F
<input type="radio"/> Air Spring P	<input type="radio"/> Exhaust T	<input type="radio"/> Start Air
<input type="radio"/> Overspeed	<input type="radio"/> Misc	<input type="radio"/> Misc <span style="float: right;">v</span>

Auto Chief  
Main Engine Control

Wrong Way

Horn Reset

SHD Pre-warn.

SLD Pre-warn.

Therm. Load Progr.

Load Limits

SHD Override

SLD Override

Progr. Override

Limits Override v

ERS-RTA-III REV: 1.1

020 040

Unit Conversion

Message Log

Back

Forward





### General

The following controls are present at the AutoChief - ME Control Panel:

### Controls

- Fuel control lever (also the combined RPM/Pitch lever when in cpp mode)
- Emergency Stop
- Responsibility Transfer between Local/Engine Control Room/Bridge
- Status communication between Bridge and Engine Control Room for Finished with Engines/ECR Stand By/At Sea
- Control Mode between manoeuvring mode and sea mode
- Slow turn request button
- Cyl pre-lube
- VIT select
- VEC select

### Status indication

- Fuel lever command request
- Bridge Telegraph
- Main Engine Shut Down
- Main Engine Slow Down
- Main Engine Fail Status
- Over-ride indicators for Shut Down/Slow Down/Thermal Load-Up programme/Load Limits
- Running hour
- Revolution counter

## 5.20 AutoChief – Main Engine Control

- ME RPM actual (digital and graphical display)
- ME RPM command (graphical display)
- ME RPM limit (graphical display)
- Bridge/ECR lever mis- match
- Fuel link command actual (graphical display)
- Fuel link command limit (graphical display)
- Fixed speed indication and set-point input

### Controllable Pitch Propeller

To operate in CPP mode the variable on page 1940 must be set to 1. This will display the CPP panel which displays the pitch and from where the main engine may be stopped and started. Access is also allowed to page MD53

Combinator mode is used when the Controllable Pitch Propeller (CPP) function is selected.

At zero pitch the engine speed is reduced to improve manoeuvrability, and as the fuel control lever is increased, then the pitch and engine speed increases until the engine is operating at full speed. The relationship between speed and pitch is fixed,

### Fixed Pitch

In this mode the propeller pitch is fixed at the optimum setting, close to the full power output of the engine. The speed of the engine is varied by the fuel control lever, with the speed signal being adjusted by the various limiters and filters.



### Emergency Stop

When this switch is activated, the engine is stopped as the fuel pump suction valves are opened, spilling the high-pressure fuel generated by the fuel pump.

### Transfer of Responsibility

The responsibility buttons are provided to select the appropriate control station for the main engine. The options are:

**Local** – This control station would be selected when a problem or defect was present within the main engine control system, such as governor or control station hardware defect. Local control will not overcome a starting system malfunction, as the starting system is common to all control stations.

**Engine Control Room** – This control station would be selected for engine manoeuvring from the engine control room, such as engine testing, or in situations when specific engine control is required (such as when a shut down or slow down is over-ridden)

**Bridge** – This control station is normally the default control station and would be used under most operating conditions. Operating from the Bridge releases engine room personnel to monitor engine room operations.

### Transfer from the ECR to Bridge

1. Check that the Bridge and ECR levers are matched by observing the indicators on the left of the fuel control lever, and the Lever mismatch light is unlit.

2. Press the push-button “BRIDGE” on AutoChief panel. The “BRIDGE” button then starts to flash.
3. When the Bridge accepts the transfer then the “BRIDGE” button turns to steady light.

Note the Bridge personnel may be engine operators manning the Bridge panel MD110.

The ship is now controlled from the Bridge, ref MD110 for details. The engine would start up in standby mode (SBE), see SBE entry data for details.

### Transfer from the Bridge to ECR

1. Check that the Bridge and ECR levers are matched by observing the indicators on the left of the fuel control lever, and the Lever mismatch light is unlit.
2. Press the push-button “ECR” on Bridge panel on MD110
3. The “ECR” button then starts to flash.
4. The operator now accepts the transfer to ECR by pressing the “ECR” button
5. The “ECR” button turns to steady light.

The ECR now has control of the engine, and should utilise the engine control lever to match the requested speed and direction from the bridge.



In case of failure of the bridge control lever the Emergency Telegraph may be used to convey engine movement requests from the Bridge.

This is carried out by:

1. Bridge presses the button of the required movement (on screen MD110)
2. The selected button on the telegraph on the Bridge and ECR starts to flash
3. The ECR personnel confirms the engine request by pressing the flashing button on their panel (MD104)
4. The engine direction and speed should be adjusted to comply with the Bridge request.
5. Move handle to relevant engine speed by point and click on the interactive field (default settings are dead slow/slow/half and full positions) or by typing in desired command in the numeric window.

The engineer on duty can visually see the operation of the engine controls, with regard to ahead and astern command and actual camshaft position. The activation of both the stop and start signals can also be seen on this panel. If Wrong Way alarm is activated, the camshaft direction does not correspond with command from bridge.

**Transfer from ECR to Local control**

1. Press the push-button “Local” on AutoChief panel
2. The “Local” button then starts to flash.

3. On the Local Control screen MD20, the operator accepts the transfer then the “Local” button turns to steady light.

The ship is now controlled from the Local control station, ref MD20 for details.

The Local Control station personnel should utilise the telegraph system to convey engine movement requests from the Bridge.

This is carried out by:

1. Bridge presses the button of the required movement (on screen MD110)
2. The selected button on the telegraph on the Bridge and Local Control panel starts to flash
3. The Local Control personnel confirms the engine request by pressing the flashing button on their panel (MD20)
4. The engine direction and speed should be adjusted to comply with the Bridge request.

**Transfer from the Local Control to EC R**

1. Press the push-button “ECR” on the Local Control screen on MD20
2. The “ECR” button then starts to flash.
4. The operator now accepts the transfer to ECR by pressing the “ECR” button on screen MD104
5. The “ECR” button turns to steady light.



### ME Status indication

The status lights are used as a communication between the Bridge and ECR as the request for engine readiness. The actual engine readiness would be discussed by verbal communications, but the status lights are used to convey a request by the Bridge and an acceptance by the ECR.

**Finished with Engines** – This would be selected when the main engine is no longer required. Finished with Engine (FWE) would be selected when the vessel is in port, or at a secure anchorage. When the FWE signal is received, the engine systems would be partly shut down, and possible heating introduced.

The following procedure could be instigated when FWE order is received:

1. Close the main engine start air isolation valve (MD60)
2. Place the Start air valve in the block position (MD20)
3. Engage the turning gear (MD20)
4. Open the Indicator Cocks) on individual cylinders
6. Close the bypass valve of the HTFW Preheater, and open the steam inlet valve (MD10)

**ECR Stand By** – When standby (SBE) is selected, then the main engine should be ready for manoeuvring, up to and including full ahead or astern. The ECR should only accept SBE when the engine and its associated system are ready to provide full manoeuvring capabilities.

As a minimum preparation the following subsystems would be ready:

1. Two diesel generators connected to the 440V board
2. Oil fired boiler operating and on-line
3. Sea suction on high (unless in light ballast conditions)
4. Auxiliary blowers operating in automatic
5. Two steering gear motors operating
7. Check that start air block valve is open.
8. Check that start air distributor block valve is open.
9. Check that indicator cocks are closed.
10. Check that turning gear is disengaged.
11. Reset any slow down or shut down alarms. Note: the speed lever must be set to stop position to be able to reset any shut downs.
12. Check that no safety overrides are present.

**At Sea** – This button is selected to communicate that the Bridge no longer requires full manoeuvring of the engine as the vessel is in open water. This will allow the engineering staff to operate the engine room systems in economical mode. As such one or more of the diesel engine would be then shut down.

The speed and power of the engine would be increased up to the required full sea speed by pressing the button marked “sea mode” which ramps the engine up in a controlled manner from manoeuvring speed to full sea speed.



### **Engine Safety Panel**

To operate the main engine safely, all critical parameters must be monitored in order to activate alarm and, if required, initiate automatic slowdown and/or shutdown of the engine.

The engine safety indicator panel will inform the operator that an engine failure has occurred and the parameters or channel that have triggered this failure. Classification Rules dictate that an engine failure requires a dedicated alarm, and that the failure should be manually reset. Adjustments of the actual failure setpoints can be adjusted within the ME Control System screen on MD19.

The various slowdown and shutdowns are monitored by the DataChief system, and transferred to AutoChief for initiation of the slowdown and /or shutdown. Each of the slowdown and shutdown parameters is grouped and represented by an indicator light on the AutoChief panel.

When the indicator light starts flashing, slowdown/shutdown procedures are initiated. The safety system gives the operator the possibility to override shutdowns and slowdowns by pressing the relevant override buttons.

The system will (depending on set-up) give the operator a warning on slow down and shut down. The default time delay for slow down to be activated is 120 seconds. Within this period the operator may cancel the slow down. The actual diode will flash as long as the trigger or cause for slow down is present.

The default time delay for shut down to be activated is 30 seconds. Within this period the operator may cancel the shut down (except for the overspeed, turning gear in and lube oil pressure). The actual diode will flash as long as the cause for shut down is present.

Note that slow turning should be performed if the main engine has stood still for more than 30 minutes. ME slow turning is carried out by manually pressing the Slow-Turn button.

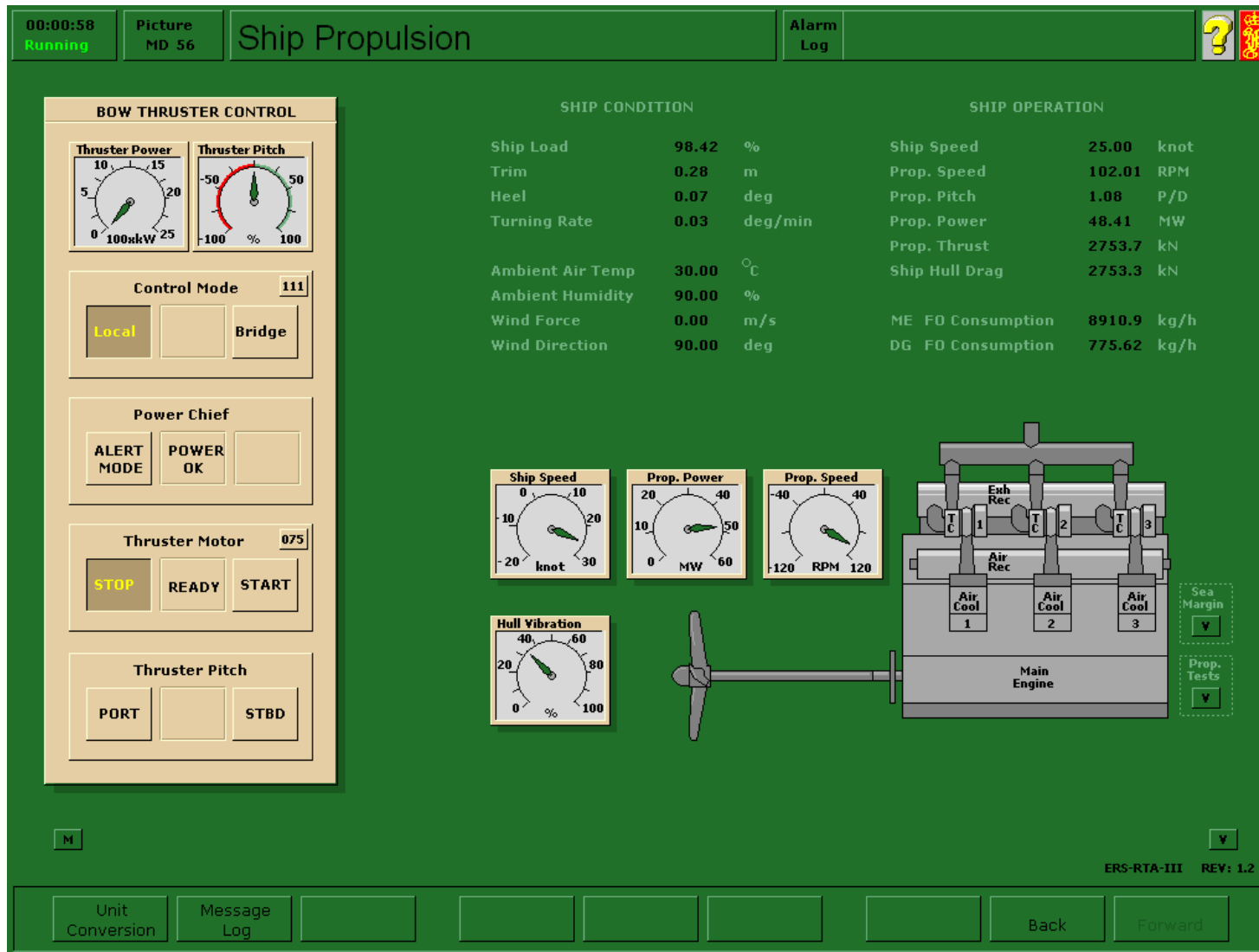



## 5.21 Ship Propulsion

### General

Ship Propulsion displays information about:

Ship Conditions

- Ship Load
- Trim
- Heel
- Turning Rate

Ambient Conditions

- Air temperature
- Humidity
- Wind Force
- Wind Direction

Ship Operation

- Ship Speed
- Prop Speed
- Prop Pitch
- Prop Power
- Prop Thrust

- Ship Hull Drag

Fuel Consumption

- ME FO Consumption
- DG FO Consumption

Indication of hull vibration is given.

Local Control of the Bowthruster is available.

### 1. Bowthrust Operation

- 1.1 Select Local control
- 1.2 Select Alert Mode to prevent auto shutdown of generators on low load
- 1.3 Ensure that there is enough power reserve available. The "Power OK" should be illuminated.
- 1.4 The Bowthrust may be run direct from No.4 Gen with the bus tie open
- 1.5 Press 'Start' and the thruster motor will start
- 1.6 Adjust pitch as required.



## 5.22 Bridge – Main Engine Control

### General

The Main Engine can be remotely controlled from the Bridge.

Indication of starting air pressure, propeller speed, fuel economy and ship speed is given.

Shut down, Slowdown and Start failure alarms are indicated and can be reset when the fault has been cleared.

### 1. To operate in Bridge Control

- 1.1 When the engine room has informed that the engine is ready select ERC stand-by and Bridge Control. The ECR should accept both situations.
- 1.2 The Engine should be in Manoeuvring mode with VIT and VEC selected.
- 1.3 The control lever should be moved to the required position and the engine should start.
- 1.4 As the engine accelerates the rate of change is governed by the load program and limits. These may be overridden in emergency to rapidly increase speed. SEVERE ENGINE DAMAGE may be caused by excessively fast acceleration.
- 1.5 When stand-by is over the At Sea command should be given and the engine placed in Sea Mode.
- 1.6 Should the Shut Down or Slow Down conditions occur a prewarning is given. Should this be placing the vessel in danger the Shut Down and Slow Down may be overridden. This could cause SEVERE ENGINE DAMAGE.

- 1.7 With responsibility in Engine Control room the control lever indicates the desired speed and direction, the ECR should then follow the Bridge lever.
- 1.8 With responsibility in Local then the Emergency Telegraph push buttons must be used to relay the command to the local control station.





---

## 5.23 Bridge – Ship Course Control

### General

The vessel is piloted from Ship Course Control.

Indication is given for:

- Ship Speed
- Rudder Angle
- Sea Water Depth
- Draft

The vessels heading can be controlled by the auto-pilot by inputting a desired heading and turning the auto-pilot on.

The rudder angle can be manually adjusted with the auto-pilot off and inputting the required set point.

Emergency operation is by push button control.

The steering gear pumps can be stopped and started from this position.

The Bowthruster can be operated from this position, Bridge control must be selected at the local station on Ship Propulsion. The motor can be started, providing sufficient reserve power is available, and stopped. The Bowthruster is operated by inputting the desired set point.

All of the fire pumps can be remotely started from this position.



## 6 SIMULATOR AND SHIP MODEL PARTICULARS

### 6.1 Auto Pulsar System

#### Description

To facilitate easy test of controller performance in various systems, the auto pulsar system is included. The auto pulsar enables auto-change of set point in intervals. The engine room systems with auto pulsar functionality vary with the simulator model but are found under the SIM CONTROL variable pages.

The following settings are typical for a low speed engine model:

Sea water temp control:	Default = 20 degC	Auto pulsar = 16 degC
Low temp fresh water temp control:	Default = 34 degC	Auto pulsar = 30 degC
High temp fresh water temp control:	Default = 85 degC	Auto pulsar = 80 degC
Lubrication oil temp control:	Default = 45 degC	Auto pulsar = 41 degC
Main engine command:	Default = 100 %	Auto pulsar = 70 %
FO Viscosity control:	Default = 16 cSt	Auto pulsar = 12 cSt
Boiler steam load	Default = 50 %	Auto pulsar = 0%
Boiler level control:	Default = 0 mm	Auto pulsar = -100mm
Boiler pressure control:	Default = 7 bar	Auto pulsar = 6.6 bar

#### Operation

Select SIM CONTROL variable page.

Set Pulsar system active (1).

Set one or more of available systems to auto pulsar active (1).

Observe that controller instantly changes set-point and the counter starts counting down from default time setting (seconds).

To switch off auto pulsar, type 0.



The following settings in seconds are typical for the low speed models:

Sea water system	Default = 180 seconds ON/180 seconds OFF
Low temp fresh water temp control:	Default = 180 seconds ON/180 seconds OFF
High temp fresh water temp control:	Default = 480 seconds ON/480 seconds OFF
Lubrication oil temp control:	Default = 480 seconds ON/480 seconds OFF
Main engine command:	Default = 600 seconds ON/600 seconds OFF
FO Viscosity control:	Default = 180 seconds ON/180 seconds OFF
Boiler steam load	Default = 480 seconds ON/480 seconds OFF
Boiler level control:	Default = 180 seconds ON/300 seconds OFF
Boiler pressure control:	Default = 480 seconds ON/240 seconds OFF

**Useful Info**

Changing ON and OFF time is done by typing desired time as a negative value.

Note that some simulator models may have counter range 0-99, this means that any number is multiplied by 10 to get the time in seconds (setting 12 is equal to 120 seconds).

600	70 %	100 %	ECR lever position
480	80 dgrC	85 dgrC	HTFW temp control
180	30 dgrC	34 dgrC	LTFW temp control
480	41 dgrC	45 dgrC	LO temp control
180	12 cSt	16 cSt	FO visco control
120	94 dgrC	98 dgrC	HFO purif temp contr
120	84 dgrC	88 dgrC	LO purif
120	58 dgrC	62 dgrC	DO purif
480	0 %	50 %	boiler steam load (deck steam valve pos)
480	6,6 bar	7,0 bar	boiler press set point
180	-100 mm	0 mm	boiler level set point