Engine Room Simulator

LM2500 Gas Turbine – GT22

Machinery and Operation Manual

Department/Author:

Arild Hermansen (s)

Approved by:

Harald Klukuken (s)

© 2003 KONGSBERG MARITIME AS

All rights reserved

No part of this work covered by the copyright
hereon may be reproduced or otherwise copied
without prior permission from
KONGSBERG MARITIME AS

**DOCUMENT STATUS**

Issue No.	Date/Year	Inc. by	Issue No.	Date/Year	Inc. by
A	14-May-03	AHE/beba			

CHANGES IN DOCUMENT

Issue No.	ECO No.	Paragraph No.	Paragraph Heading/ Description of Change

TABLE OF CONTENTS

Section	Page
1	INTRODUCTION..... 1
1.1	Basic Gas Turbine Theory 1
1.1.1	Compressor Stage 3
1.1.2	Combustion Stage..... 4
1.1.3	Turbine Stage 5
1.1.4	Basic System Calculations 6
1.2	GT-LM2500 Training Package 9
1.2.1	Model Software 9
1.2.2	Main Particulars..... 10
1.2.3	GE LM2500 System..... 11
2	GAS TURBINE MACHINERY AND OPERATION..... 18
2.1	Fuel Supply System 18
2.1.1	Operation..... 19
2.2	Lubrication Oil System..... 20
2.2.1	Operation..... 21
2.3	GT Starting / Ignition System 22
2.4	Water Wash System..... 24
2.4.1	Operation..... 24
2.5	Engine Fuel System..... 25
2.6	GT - Fire Detection and Extinguish..... 28
2.7	GT - Sensing systems..... 30
2.8	Gas Turbine Operator Panels #1..... 32
2.8.1	Operation..... 33
2.8.2	Bleed Air System 33
2.9	GT Local Operation Panel #2..... 34
2.9.1	Start up and Shut down of Gas Turbines..... 38
3	GT LOAD SYSTEM 49
3.1	Water Brake Load 52
4	GT SPEED CONTROLLER AND AECM 54
4.1	Speed and Power Controller..... 55
4.1.1	Optimising Procedures for Speed Controller..... 58
4.1.2	Ziegler-Nicholls Test..... 63
4.2	Types Of Control Action 67
4.2.1	Proportional Action..... 67
4.2.2	Offset or Droop 67
4.2.3	Integral Action or Reset..... 68
4.2.4	Derivative Action or Proportional Rate 68
5	MALFUNCTION FEATURES..... 69

6	APPENDIX 1: ALARM LIST.....	77
7	APPENDIX 2: MALFUNCTION LIST	77
8	APPENDIX 3: VARIABLE LIST.....	77
9	REFERENCES	77

1 INTRODUCTION

1.1 Basic Gas Turbine Theory

The practical process used within the General Electric design of the LM2500 uses the basic gas turbine cycle, such as the Joule or Brayton cycles. The process can be broken up into three main stages:

- A. Atmospheric air is drawn in and compressed from 1 to 2 in the multi-stage compressor. The compression process is adiabatic and reversible in the ideal process, but has an isentropic efficiency of 85~90% in the real process.
- B. Heat is added at a constant pressure from 2 to 3 in the combustion chamber.
- C. The heated and compressed air is expanded from 3 to 4. The expansion process is also adiabatic and reversible in the ideal process, as with the compression process. With the twin spool arrangement of the LM2500, the expanded work occurs in two stages; the high pressure turbine (which drives the compressor) and the low pressure turbine (which drives the output shaft).

At point 4 the working substances (air) (and the combustion gases) are returned to the atmosphere again in a constant pressure process.

The gas turbine engine is often referred to as an external combustion engine because the combustion processes occur in devices that are separate from their work developing engines (turbines).

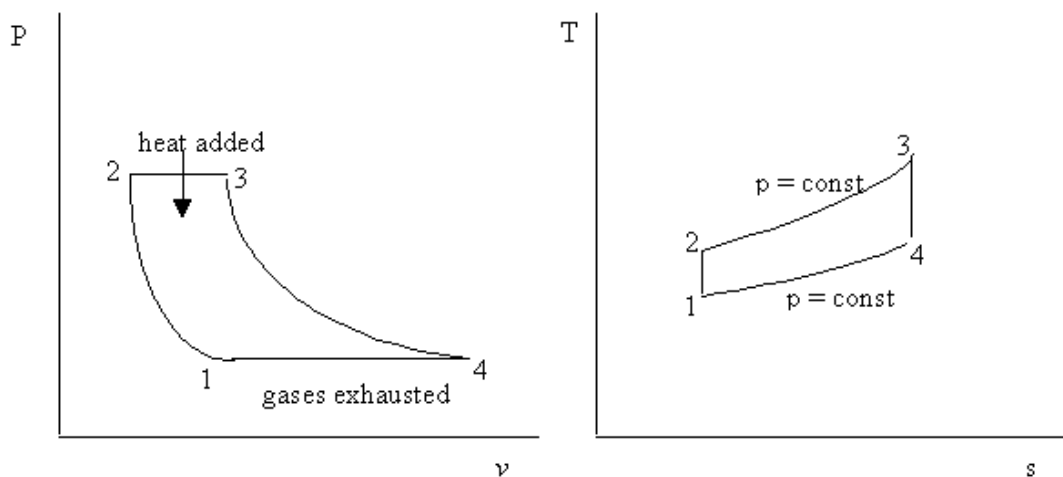

Figure 1

If each turbine has its own isentropic efficiency then the cycle can be shown on a T~s diagram as shown below

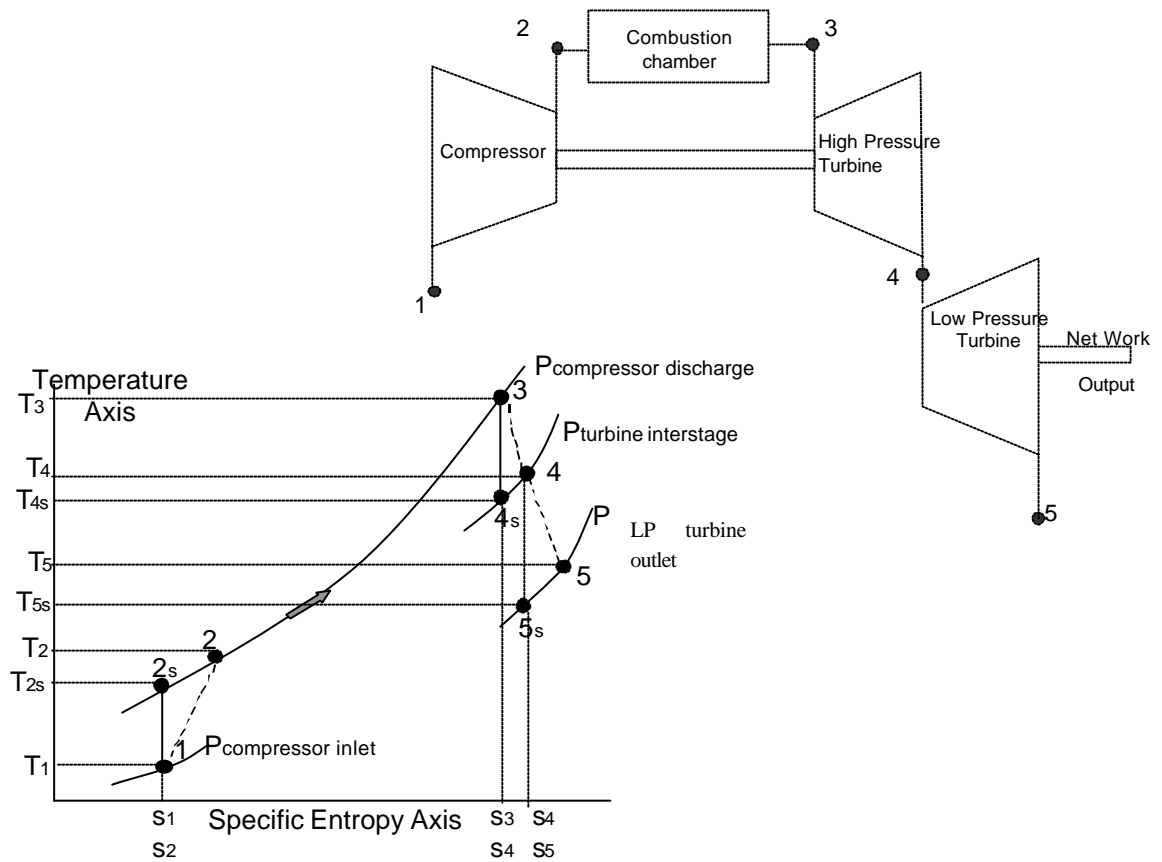

Figure 2

Line 1-2 represents irreversible adiabatic compression between P_1 and P_2
 Line 2-3 represents constant pressure heat addition in the combustion chamber
 Line 3-4 represents irreversible adiabatic expansion between P_2 and the turbine inter-stage pressure P_i
 Line 4-5 represents irreversible adiabatic expansion between the inter-stage pressure P_i and P_1

Line 1-2_s represents ideal isentropic compression between P_1 and P_2
 Line 3-4_s represents ideal isentropic expansion between P_2 and P_i
 Line 4-5_s represents ideal isentropic expansion between P_i and P_1

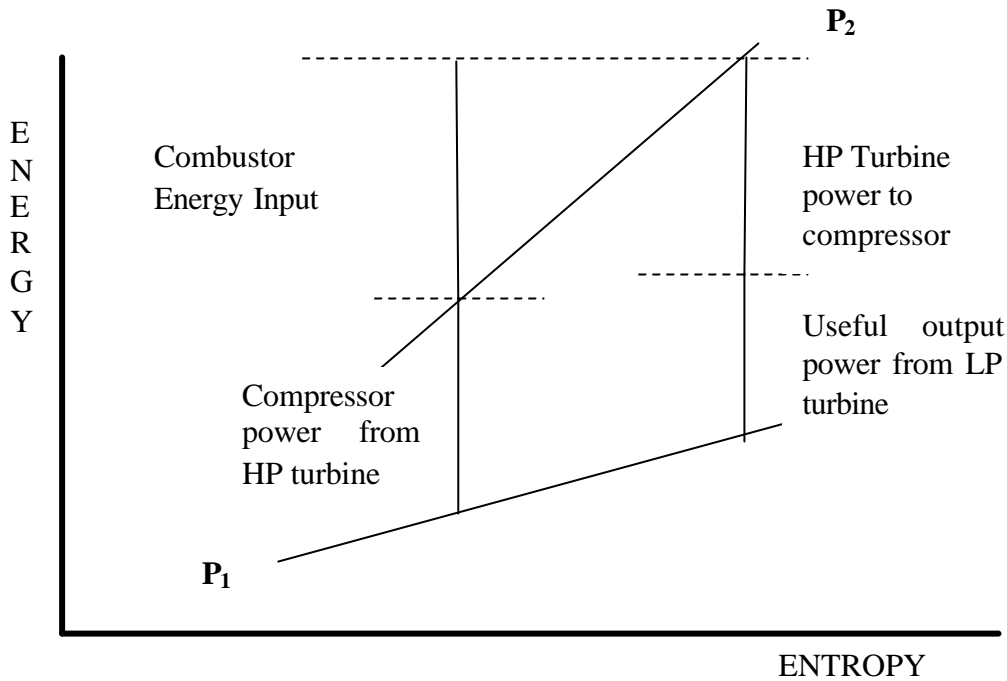

Figure 3

This graph illustrates the relationship between the energy input at the combustor, and the useful energy output at the LP turbine. The compression stage changes the pressure from inlet pressure, P_1 , up to the operating pressure of the combustion unit, P_2 . At this stage energy is added and the entropy will increase. The energy required to drive the compressor absorbs most of the energy available after the combustion chamber. The remaining energy is used by the LP turbine to drive the output shaft. The two turbines drop the pressure from P_2 to P_1 .

1.1.1 Compressor Stage

To develop the high pressure ratios required, multi-stage axial compressors are employed. The LM 2500 uses a 16 stage, axial-flow compressor developing a 17:1 pressure ratio. As each stage operates at the same speed, it is possible that the first compressor stages could be overloaded, and later stages would operate inefficiently at some compressor rotor speeds. To avoid this problem, variable stator vanes are required.

The inlet guide vanes and the first six stages of stator vanes are controllable in pitch, and are modelled in the programme as the Variable Stator Vanes (VSV). The pitch is controllable in order to match aerodynamically the low-pressure stages of compression to the high-pressure stages and to prevent stall. The variable vanes allow the compressor stator blades to attain the correct angle of attack over the wide range of the turbine operation. The angles of the blades are adjusted to compensate for changes in compressor rotor speed.

This adjustment will prevent the air flow within the compressor stalling (also called surging), and is required for the first stage of the compressor only. By utilising this method

of stall prevention in the early stages, the problem of choking in the latter compressor stages can also be reduced.

1.1.2 Combustion Stage

The Combustion Chamber is where the energy input, in the form of heat, is added to the gas turbine system. The LM2500 unit uses an annular combustor design with 30 fuel nozzles arranged around its periphery. This combustion unit configuration is very compact, and it widely used within industrial gas turbine units.

The combustor requires a constant flame, which is achieved by spraying or atomising the gas oil fuel. Combustion occurs within three stages; the first is the primary zone, where 15 to 20% of the air is introduced around the fuel spray, (in the same direction of flow), to generate the high temperatures required for rapid combustion.

The second stage then admits another 30% of the air through holes in the flame tube to complete the combustion process. The air holes that admit the air must be carefully positioned to avoid chilling the flame, and hence producing uneven or delayed combustion. The final stage is the dilution stage, where the remaining air is mixed with the products of combustion to cool them to the required temperature required at entry to the high pressure turbine. This stage must provide sufficient turbulence between the combustion products and the air to ensure that the temperature distribution of the gas stream leaving the combustor is even, as high temperature areas would damage the turbine blades.

The type of burners used in gas turbines are very similar to those used in modern steam boilers, namely spill and duplex burners. Both are used to achieve good atomisation of the fuel across the full range of fuel flow. In the duplex burner, two orifices are used, each with its own supply channel. The small central orifice is used for small flows, whilst the outer larger orifice is used for the full load flows. Fuel pressure alone is used to achieve the atomisation process rather than air or steam assistance, although air is admitted through the burner tip on its periphery to maintain the burner tip free from carbon deposits.

Under normal operating conditions, the combustion within the gas turbine is self maintaining. The ignition and starting systems are used to initiate this combustion process. With the separate power turbine used for the LM2500, only the gas generator has to be started by the external means. During the start (by either the air or hydraulic start unit) the compressor must rotate at sufficient speed to generate the quantity of air required. An igniter plug is situated within the primary combustion zone, and the high intensity surface discharge of the igniter provides the energy required to initiate combustion. The flame produced will then “light round” the annular combustion chamber. To ensure a long igniter life-time the igniter is situated just within the outer edge of the fuel spray. As the igniter can discharge up to 100 sparks per minute, the igniters require renewal after a period of operation.

For the LM2500 unit, using liquid fuel, the hot section and combustor will need to be refurbished after 16,000 hours of operation (about two years at base load). After 50,000 hours (six years at base load), the entire engine will need to be overhauled.

1.1.3 Turbine Stage

After the combustion chamber, the hot gases travel to the high pressure turbine. To ensure that the casing temperature is not excessive, and hence a danger to ignite any oil sources present, then the casing is cooled by air. A gap is provided in the wall or casing skin, so that coolant air can travel along it.

The gases then reach the turbine stages, which on the LM 2500 Gas-Generator Turbine is a two stage, high-temperature, high-pressure air cooled turbine. This turbine drives the compressor and the auxiliary drive gear box. The turbine utilises the axial design, so that engineers familiar with steam turbine designs would recognise the fixed nozzle blades, and rotor blades. The main difference between the gas and steam turbine would be the operating temperatures of the turbines. The gas temperature entering the high pressure turbine would be in the region of 1300K or 1030°C. This means that the blade metal temperatures would approach this level, and thus the blade material and blade cooling must be designed for the purpose. The cooling of the turbine blades is by air (hence the term air cooled turbine), which is passed through the blade, exiting by small or porous holes along the blade surface. Cooling of the blades allows the turbine to operate at these high temperatures, and hence provide improved overall thermal efficiency of the turbine unit.

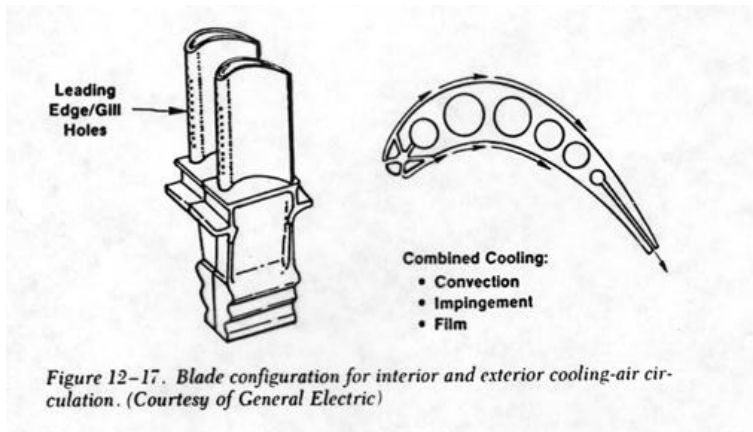

The materials used for these high temperature duties are classed as “superalloys”, such high-chromium, carbide strengthened, cobalt base superalloy, or cast, precipitation hardened, nickel based superalloy. As well as utilising special alloys, the process of manufacture is improving to include directional solidification (to align the material crystal in the radial direction) and even single crystal castings.

In the low pressure turbine, the temperatures are lower, with an inlet temperature of 1100K or 850°C, thus the blades are no longer required to be cooled, and the material specification is reduced to high strength, nickel based alloys.

1.1.4 Basic System Calculations

For the LM2500 unit simulated within this model, the output power from the LP turbine is 20MW. The following data is taken from the simulation model when operating at this power output.

	On electrical load	On water brake load
Output power	20 MW	20 MW
Ambient or inlet temperature	30°C	30°C
Compressor outlet pressure	16.8 bara	16.8 bara
Fuel input flow Calorific value of fuel = 42MJ/kg	4745 kg/hour	4710 kg/hour
Power turbine inlet temperature	820°C	819°C
Power turbine inlet pressure	3.88 bara	3.86 bara
Specific fuel consumption	237.6 g/kWh	236 g/kWh
Power turbine speed	3600 rev/min	3600 rev/min
Gas generator speed	9400 rev/min	9380 rev/min

Table 5

To illustrate the various pressure, and temperatures within the system, a basic calculation will be used. This calculation does not illustrate the mathematical modelling used, and is only to gain an understanding of the system thermodynamics.

The intake conditions are set at 30°C or 303K and 0.98 bara. (note all pressures and temperatures for calculations will be quoted in absolute units of bara and K).

If isentropic compression is assumed, then at the operating temperatures c_p for air = 1.05 kJ/kg K and $\gamma = 1.39$.

Thus as the compressor discharge pressure is given from the model as 16.8 bara, then from

$$T_{2s} = T_1 \left(\frac{p_2}{p_1} \right)^{\frac{\gamma-1}{\gamma}} = 303 \left(\frac{16.8}{0.98} \right)^{\frac{1.39-1}{1.39}} = 616K$$

Considering isentropic efficiency, then from $\eta_{isentropic} = \frac{T_2s - T_1}{T_2 - T_1}$ and using an isentropic efficiency of 90%, then the compressor discharge temperature would rise to 650.8K

From text book reference graphs ³, the temperature rise within the combustion chamber can be found.

An Air/Fuel ratio of 50 will be assumed, and this produces a temperature rise of 715K within the combustion unit, at the inlet temperature of 650K. This figure can be checked with the heat input from the fuel. The model gives an average fuelling rate of 4728 kg/hour or 1.31 kg/sec. This equates to a heat input of 56.2 MW for the calorific value of the fuel used. (See variable page 50000 for Calorific Value used within the model.)

This heat input gives a first estimate of turbine thermal efficiency of $20/56.2 = 35.6\%$

Equating the heat input with the increase in air temperature

From $Q = m_{\text{air}} \times C_p \times \Delta T$, then $56.2 \times 10^3 = (50 \times 1.31) C_p \Delta T$.

At these temperatures and with the A/F ratio of 50, then $C_p = 1.18 \text{ kJ/kg K}$, so $\Delta T = 727\text{K}$, similar to the empirical result from the graphs.

Hence the temperature at inlet to the high pressure turbine is $651 + 715 \sim 1366\text{K}$.

The work done within the high pressure turbine equates to the work absorbed by the compressor it is driving, hence the temperature drop across the high pressure turbine can be found.

From $m_{\text{air}} C_p \Delta T = m_{\text{gases}} C_p \Delta T$, and equating the mass flow of air, with the mass flow of the air and gas, then

$$65.5 \times 1.05 \times (651 - 303) = (1.02 \times 65.5) \times 1.18 \times \Delta T$$

hence the temperature drop across the high pressure turbine is 303K.

This produces a temperature at inlet to the power turbine as $1366 - 303 = 1063\text{K}$. This compares with the simulation model figure of 1093K at full load, a difference of 30K.

The simulation model also predicts a power turbine inlet pressure of 3.87 bara. With the expected power output of 20MW, then with $C_p = 1.14 \text{ kJ/kg K}$ at these temperatures and air/fuel ratio's, thus the temperature change expected in the power turbine will be $20/65.5 \times 1.02 \times 1.14 = 263\text{K}$, hence the turbine outlet temperature will be 800K or 527°C.

Finally the calculation of the specific fuel consumption is the quantity of fuel consumed for a given output. Thus $\text{SFC} = 1.31 \times 3600/20 \times 10^3 = 235.8 \text{ g/kWh}$.



These figures suggest the temperature and pressure stages within the gas turbine cycle, and when isentropic efficiencies are taken into account they should be modified.

STAGE	Temperature (°C)	Pressure (bar gauge)
Compressor inlet	30	-0.02 bar
Compressor outlet	378	15.8
Combustion inlet	378	15.8
Combustion outlet	1093	15.8
High pressure turbine in	1093	15.8
High pressure turbine out	790	2.9
Power turbine inlet	790	2.9
Power turbine outlet	527	0.0

Table 6 **Ideal calculated values**

By understanding the expected pressures and temperatures within the gas turbine, then the engineer should become more aware that turbine operations are outside the normal operating range, rather than rely on the functioning of the alarm channels.

1.2 GT-LM2500 Training Package

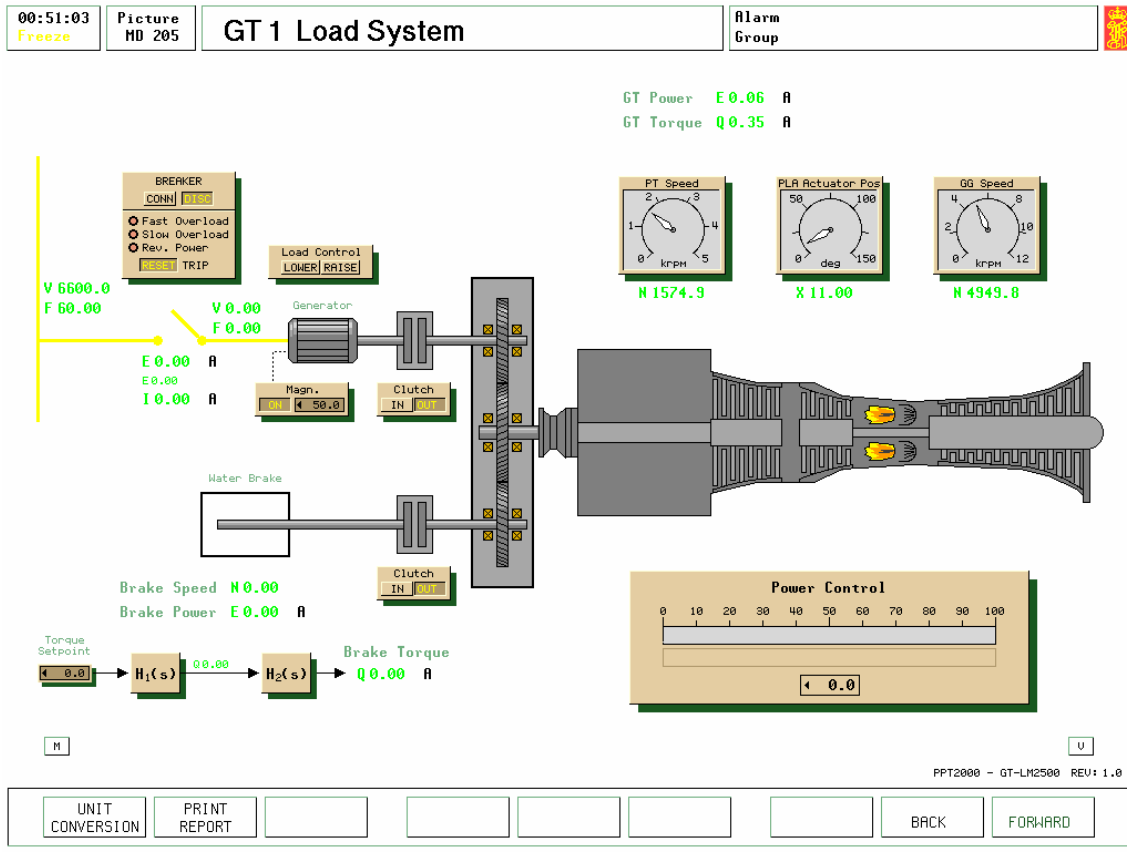

Fig. 7 “GT Load System”

1.2.1 Model Software

The Gas Turbine simulation software uses two General Electric LM2500 gas turbine units. Each of these units can be connected to either an electric load or a water-brake via reduction gears, as shown in Fig 1. Hence the load can be changed with:

- Operation at constant speed when using the electric load, or
- Operation using the water brake at either the propeller law (Power \propto Speed³) or power as a function of both speed and torque

The General Electric heavy-duty gas turbine is a two-shaft gas turbine. The gas turbine model GE-LM2500 comprises a single spool gas generator followed by a power turbine.

1.2.2 Main Particulars

Type	GE LM 2500-30 (General Electric)
Power	19700 kW
Speed	3600 rpm (Power Turbine)
SFC	237 g/kWh (at 100% load)



Figure 8 Gas turbine module within housing

1.2.3 GE LM2500 System

This graph illustrates the change in output power when the ambient temperature changes. The broken line shows the temperature of the gas generator output for the differing power and ambient temperature changes, and it is this parameter that limits turbine output.

Figure 9¹

LM2500 Gas Turbine Generator Output at 60 Hz, lapse curve rating:

60% RH, SEA LEVEL, 3600 RPM	FUEL FLOW, MMBTU/h LHV (GJ/h)	---
6/16 INCH WC INLET/EXHAUST LOSSES	EXHAUST MASS FLOW lb/s (kg/s)
LIQUID FUEL 18400 BTU/LB (LHV), DRY ENGINE	EXHAUST GAS TEMP °F (°C)	- - - -

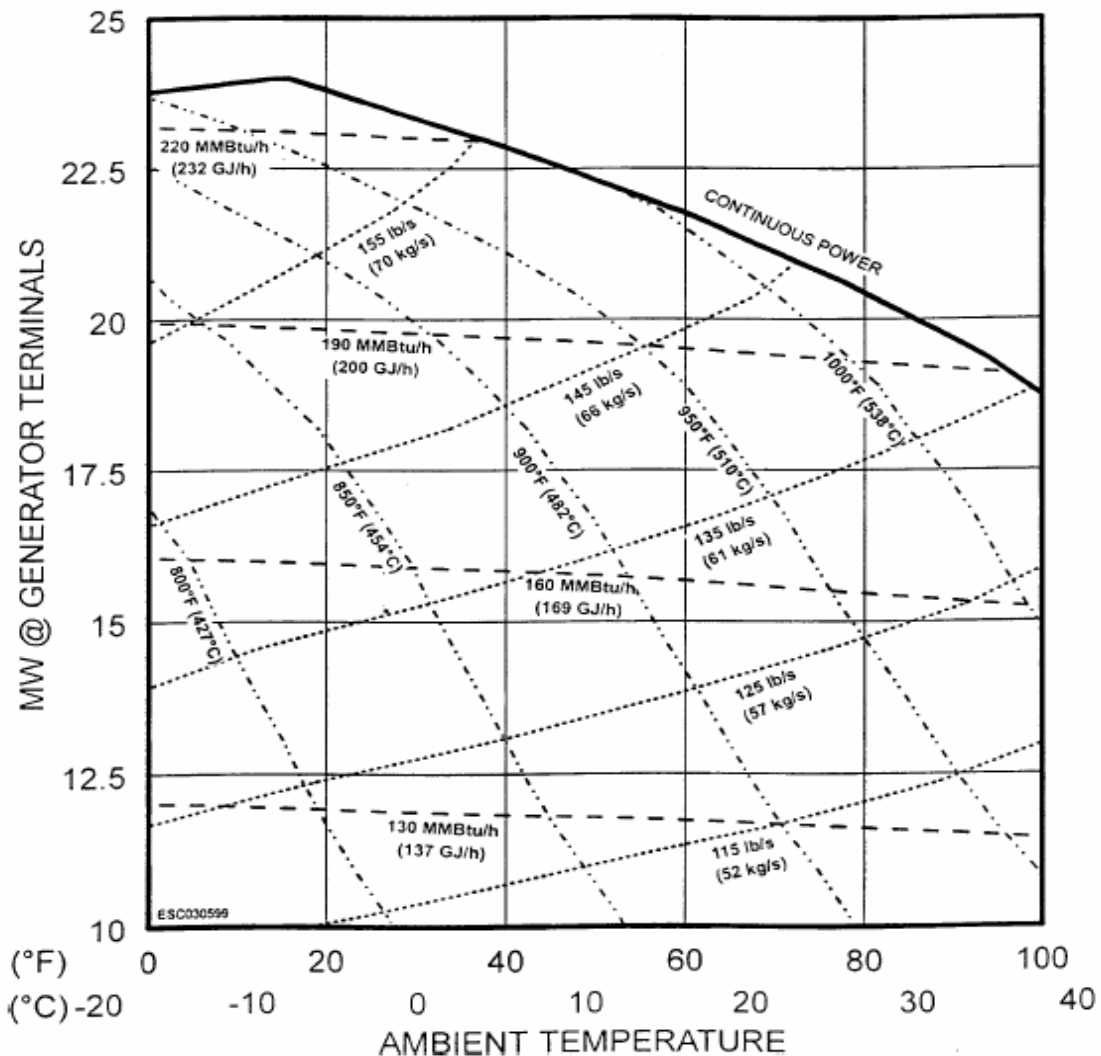



Figure 10 Gas turbine and generator assembly

The LM 2500 system comprises the four major assemblies:

1. Base Enclosure Assembly, comprising
 - base structure and shock mounts
 - enclosure
 - inlet components
 - exhaust components
2. Gas Turbine Assembly, comprising
 - inlet components
 - gas generator
 - compressor
 - compressor discharge chamber
 - combustor
 - high pressure turbine
 - accessory drive system
 - low-pressure turbine (or power turbine)
 - high speed coupling shaft
 - exhaust components
3. Lube Storage and Conditioning Assembly
 - This is remotely located from the gas turbine and incorporates an oil storage tank, a heat exchanger, a duplex filter and a scavenge oil check valve. It supplies cooled and filtered lubrication oil to the gas turbine.
4. Advanced Engine Control Module (AECM)
 - This is the control interface between the gas turbine module and the local operating panel (LOP). It provides the fuel command to the gas turbine, and includes the automatic start/stop sequence programs, overspeed and overtorque protection, as well as the other control and protective functions.
 - The AECM is not shown as the usual console in the engine room, but its main functions will be included in the simulator model.

Basic operating principle of the gas turbine unit

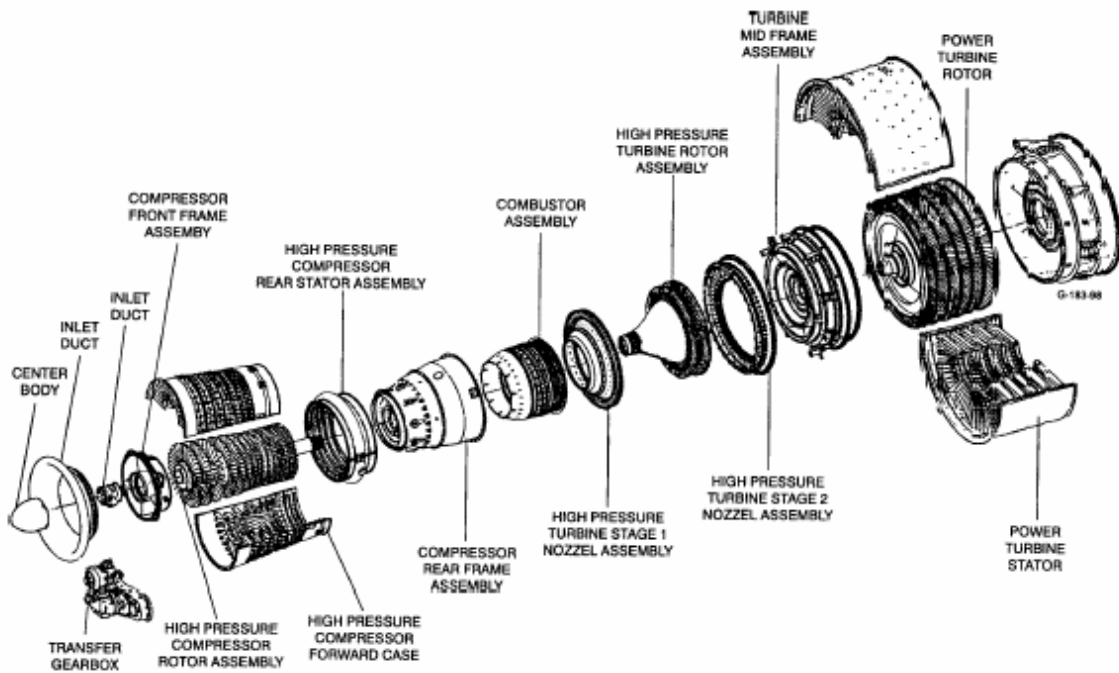

Figure 11

During gas turbine operation, air from the inlet section enters the compressor where its pressure is increased. The compressor is a multistage axial flow compressor and consists of a rotor and a stator within a casing.

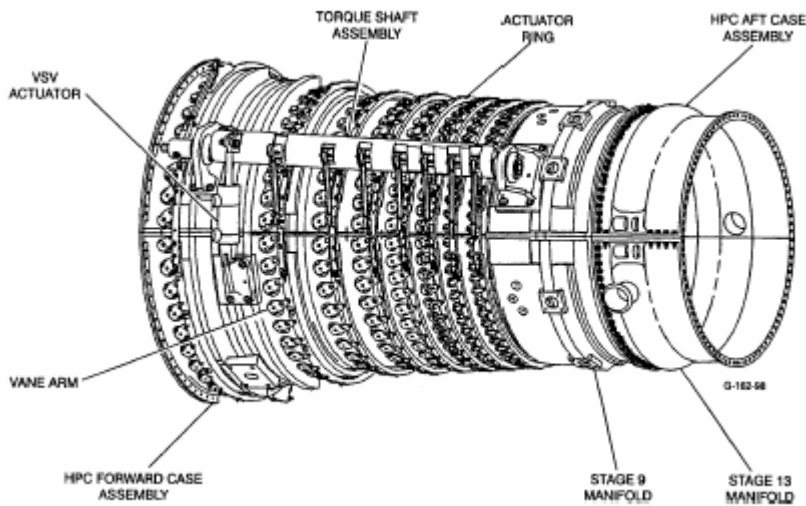

Figure 12 Compressor stator arrangement showing VSV Actuator

The high-pressure air is then directed into the combustion section where it is mixed with fuel and ignited, raising its temperature.

Fuel preparation, mixing, and burning takes place in the combustion section, which consists of the combustor, the fuel manifold, fuel nozzles, and igniters.

The combustor is annular and consists of four major components riveted together: cowl (diffuser) assembly, dome, inner skirt, and outer skirt. The whole assembly, in conjunction with the compressor rear frame, serves as a diffuser and distributor for the compressor discharge air. It furnishes uniform air flow to the combustor throughout the operating range, thereby providing uniform combustion and even temperature distribution at the turbine.

Thirty vortex inducing axial swirl cups in the dome (one at each fuel nozzle tip) provide flame stabilization and mixing of the fuel and air. The interior surface of the dome is protected from the high temperature of combustion by a cooling air film. Accumulation of carbon on the fuel nozzle tips is prevented by venturi-shaped spools attached to the swirler.

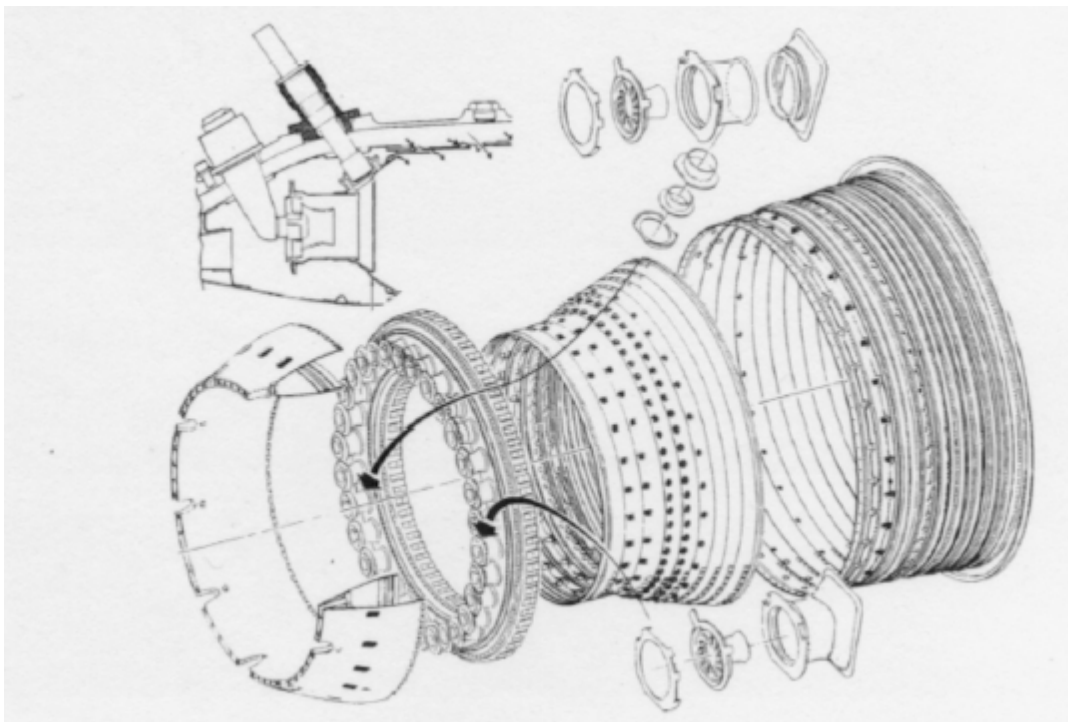

Figure 13 Annular Combustor

Primary combustion and cooling air enters through closely spaced holes in each ring of the annular construction. These holes help to stabilise the flame in the centre of the system, and admit the balance of the combustion air.

Dilution holes are employed on the outer and inner liners for additional mixing to lower the gas temperature at the turbine inlet. Combustor/turbine nozzle air seals at the aft end of the liners prevent excessive air leakage while providing for thermal growth.



The hot gases from the combustor are directed into the high-pressure turbine, where power is extracted from the gas stream to drive the compressor rotor. The high-pressure turbine is mounted on the same shaft as the compressor. The compressor consumes approximately 75% of all the energy available from the combustion process. The remaining energy is available for useful work from the power turbine.

From the high-pressure turbine the gases, now at reduced pressure and temperature, are ducted into the low-pressure turbine (or power turbine) and through the exhaust section into the exhaust collector. The power turbine is the component of the gas turbine engine that produces useful work. The power turbine rotor is directly mounted on the output power shaft, which drives aft through the exhaust collector.

Figure 14 Power turbine element

The exhaust section consists of the inner and outer duct forming the diffusing passage from the power turbine rear frame into the exhaust collector.

Each gas turbine is separately surrounded by a noise-reducing and airtight enclosure. The enclosure is resiliently mounted on the foundation with shock mounts.

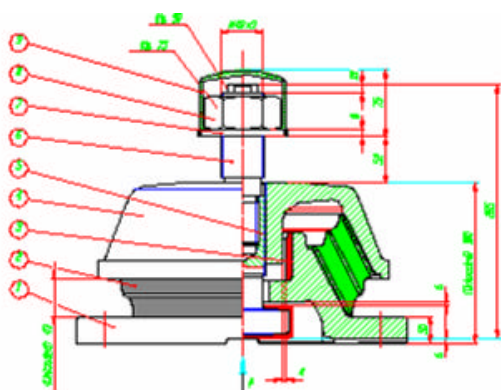
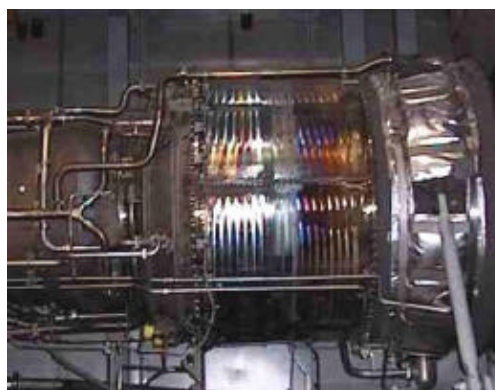

*Figure 15
Resilient mounting*

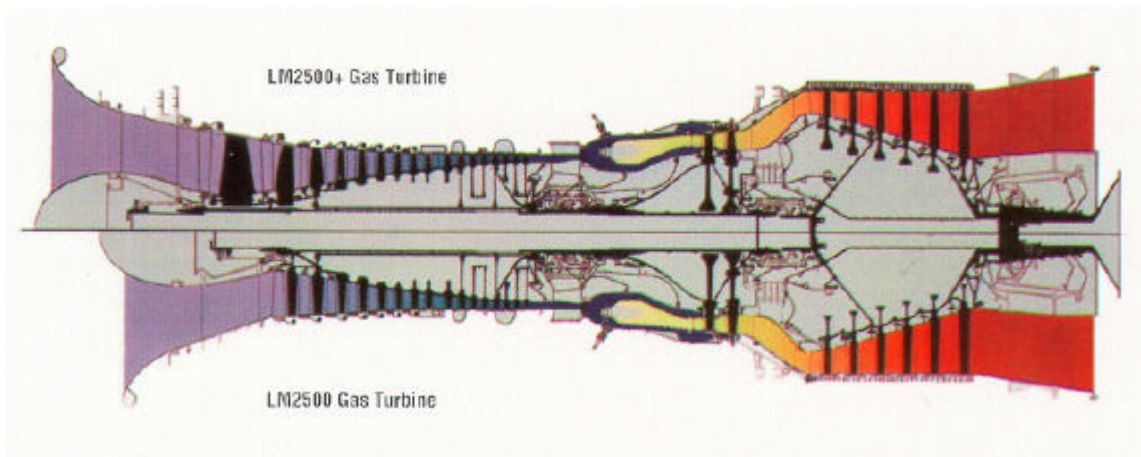

Figure 16 Comparison of the family of GE LM2500 gas turbine units

The gas turbine model used within this simulator package is the LM2500 series. To provide additional power many modern marine plants are specifying the higher output of 25MW from the LM2500+ gas turbine, which is physically a larger unit as shown in Fig 16.

Both the LM2500 and LM2500+ units are classed as free power turbine units, in that the power turbine is not mechanically connected to the gas generator or compressor as shown in Fig 17. This arrangement provides greater flexibility for the power turbine to operate at a speed different to the gas generator section.

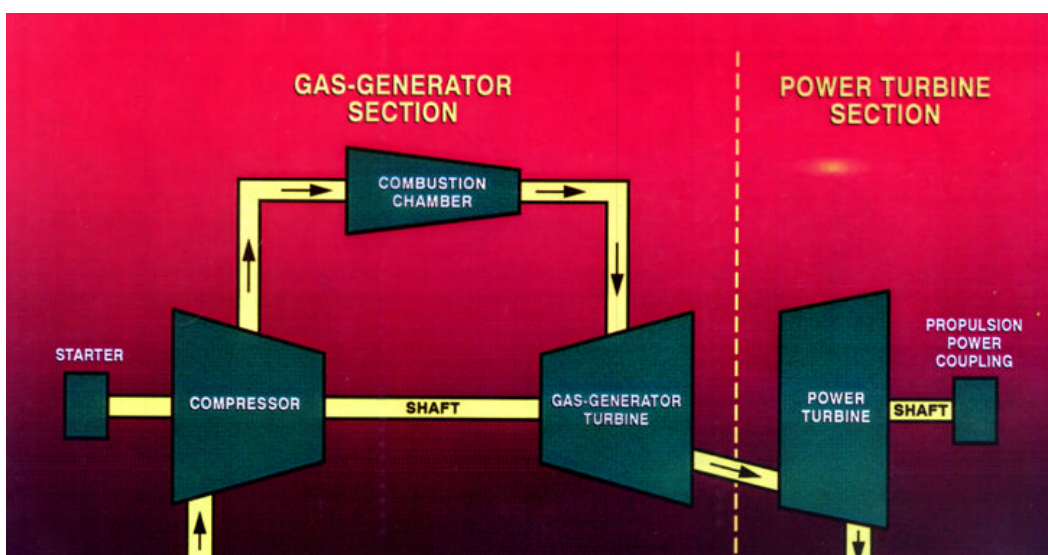

Figure 17 Overview of the configuration of the gas turbine

The basic sub-systems of the gas turbine are:

a) starting air system

The purpose of the starting air system is to drive the gas generator mechanically to a speed at which the gas generator can start. The starting air system is also used to water wash and motoring the gas generator in certain maintenance tasks.

b) ignition system

The ignition system is used to initiate combustion during the start sequence. It produces high-energy sparks that ignite the mixture of air and fuel in the combustion chamber when starting the gas generator.

c) fuel system

The fuel system supplies filtered fuel to the gas turbines pumping from the day tanks to the engines via booster pumps and oil/water separators.

d) engine fuel system

The engine fuel system delivers a metered flow of fuel, recirculates fuel, or routes fuel depending on the selected mode of operation. It also positions the compressor VSV's to regulate primary air flow through the engine during all modes of operation.

e) lubrication system

The engine lubrication system circulates, cools, cleans and contains the flow of lubrication fluid through the gas turbine gearboxes and sumps.

f) bleed air system

The bleed air system permits to extract high pressure air from the compressor discharge chamber to warm-up the ship inlet duct of each engine, and avoid icing.

g) fire detection and extinguish systems

Fire detection in the gas turbine is provided by the gas turbine fire system which stops the engine and extinguish the fire by using CO₂.

h) sensing systems

Extensive monitoring capability of all significant systems functions is provided by numerous probes and sensors located at strategic points throughout the gas turbine and its associated equipment.

2 GAS TURBINE MACHINERY AND OPERATION

2.1 Fuel Supply System

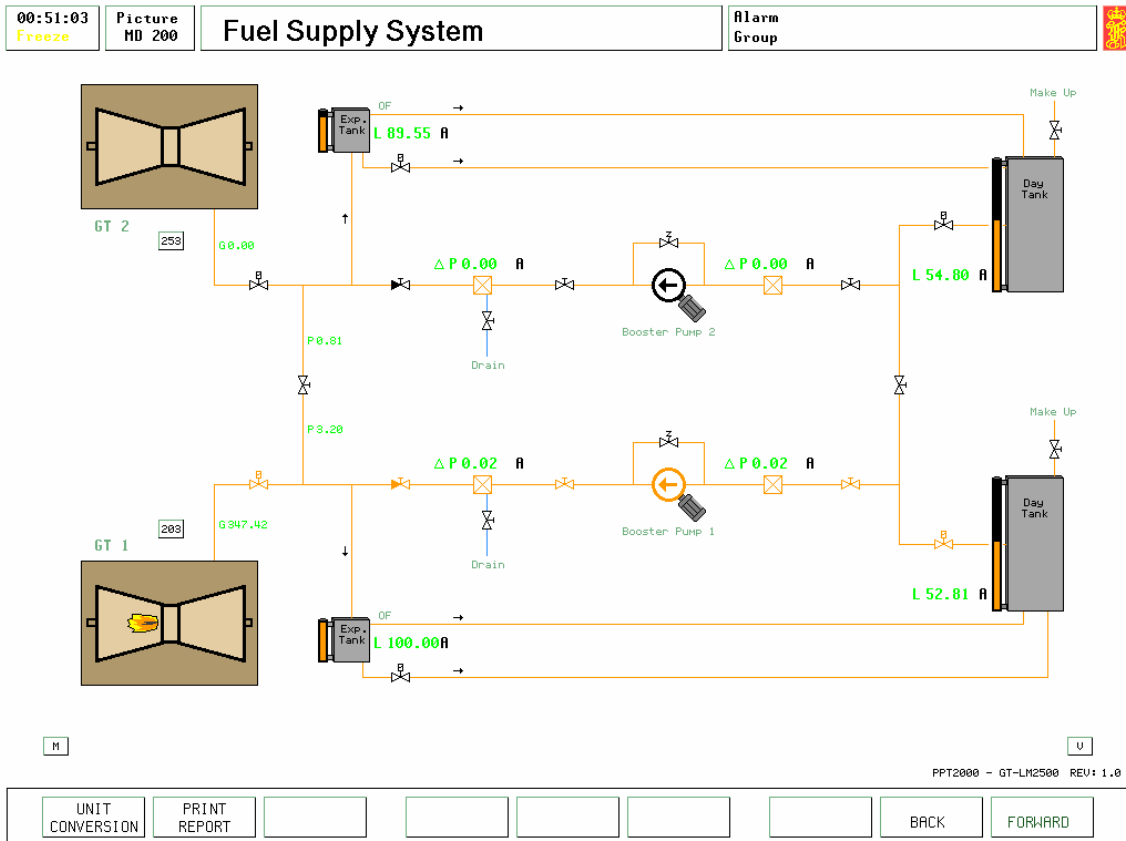

Figure 18

The main components of the fuel supply system are:

- fuel pump suction filter
- booster pump with relief valve
- coalescer filter, with water drain
- expansion tanks
- pneumatically actuated quick closing valves

Fuel from the day tanks is supplied to the booster pumps, which supply the 3 bar delivery pressure to the module fuel inlet located on the floor of the base enclosure. This supply pressure is maintained constant by a bleed line that relieves to the expansion tank fitted above the fuel supply system. The expansion tank then overflows excess fuel back to the day tank.

If the overflow shut off valve (between the expansion tank and the day tank) is closed, the expansion tank will be filled by the booster pump and flooded. The simulator model will cause any overflow of the expansion tank to trigger an engine space fire.

2.1.1 Operation

1. Open outlet valves from the day tank
2. Open the booster pump suction and delivery valves
3. Open the supply valves to the gas turbine.
4. Open overflow shut-off valve from expansion to day tank.
5. Start booster pump.
6. Refill day tank, when required.

NOTE! The water drain of filter is not modelled in detail, but included for procedural purpose.

2.2 Lubrication Oil System

00:51:03 Freeze	Picture HD 201	GT 1 Lube Oil System	Alarm Group
--------------------	-------------------	----------------------	----------------

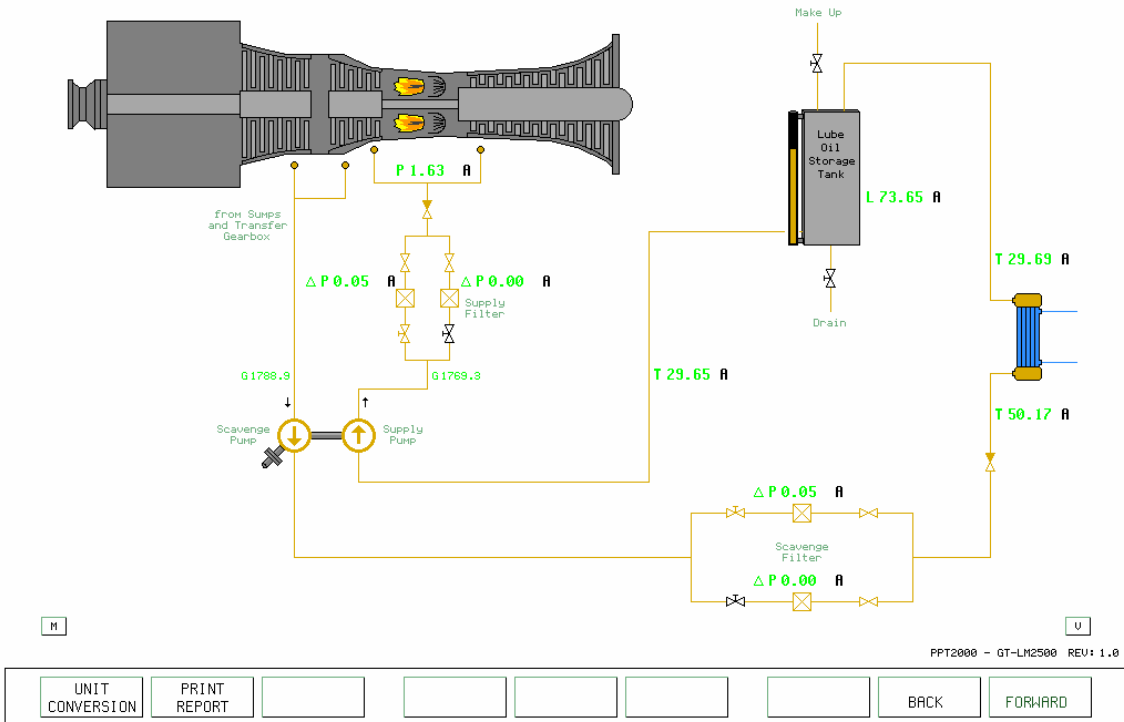

Figure 19

The lubrication oil system consists of:

- oil storage tank
- lube supply and scavenge pump
- supply oil filter (duplex)
- supply check valve
- scavenge oil filter (duplex)
- oil cooler
- air / oil separator (within oil storage tank vent)

Three separate flows are maintained through the system:

1. Lubricating oil supply,
2. Lubricating oil scavenge or drain system
3. Sump vent.

The lubricating supply and scavenge pump is driven from the power turbine output gear box.

The oil is fed by gravity from the storage tank to the supply lubricating oil pump. The pump discharges through a duplex supply oil filter and is delivered into a distribution manifold through the supply check valve. This supply oil supplies the nozzles that spray directly on the gears, bearings and splines.



The oil from the gears and bearings drains out of the gearboxes and oil sumps, where the scavenge oil pump evacuates these drains through the duplex scavenge filters and system oil cooler before returning the oil back to the oil tank. Thus filtered and cooled scavenged oil is stored in the lube oil storage tank. Entrained air and other gases are vented to the atmosphere through the tank demister/flame arrester.

A scavenge check valve is provided between the filters and cooler to prevent the back-flow of the oil into the gas turbine sumps and gearboxes after engine shutdown.

The sump vent flow prevents excessive oil consumption by reclaiming vaporised oil out of the vent air exhausted from the gas turbine sumps. This reclaiming is carried out by the air / oil separator (not shown), and drains into the lubricating oil storage tank.

2.2.1 Operation

1. Open one supply filter
2. Open one scavenge oil filter
3. Check that the oil storage tank is over 50% full

2.3 GT Starting / Ignition System

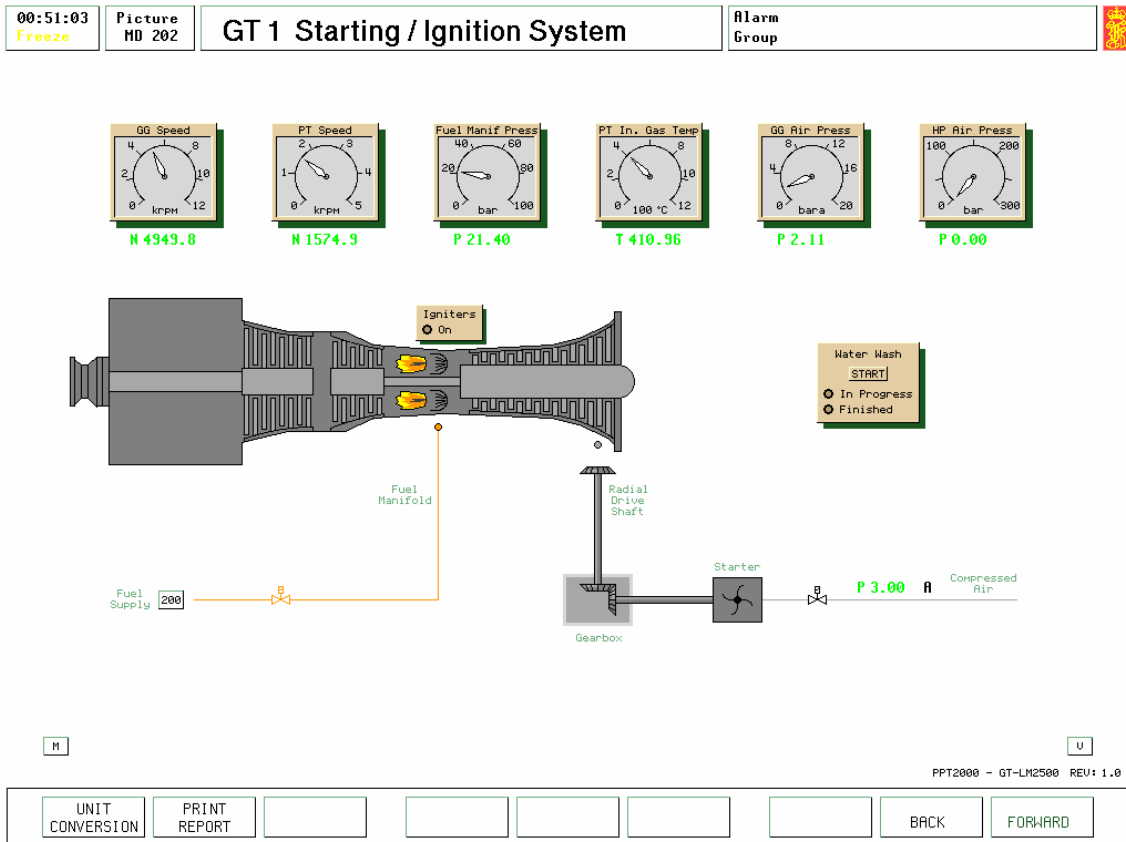

Figure 20

The main components of this system are:

- high pressure air bottles
- air reduction station
- starter air regulating valve
- pneumatic starter
- ignition exciter boxes
- spark igniters

From the high pressure air bottles (250 bar) available for each gas turbine, the air flows through the air reduction valves where the pressure is reduced in two stages (250 to 20 and then 20 to 3 bar) to get the ideal pressure to start the gas turbines. Shut-off valves are provided before and after the reduction air valves, and to isolate the air circuits from each turbine starter.

In case of air system failure the air circuits are interconnected. The storage capacity of the high pressure air is sufficient to start the gas turbines four consecutive times, under worst conditions within a 60 seconds start sequence.



The starter air regulating valve is a solenoid controlled air actuated butterfly valve, capable of providing two regulated air outputs; one for starting and another for motoring.

When performing maintenance tasks in the gas turbines, which may need to motor the turbine at low speed, such as for water washing the turbine, the push-buttons on the screen MD202 should be operated.

The pneumatic starter consists of a high-speed turbine driving an output shaft through a set of reduction gears and an over-running clutch assembly. During start sequence, when the speed of the gas generator (N_{GG}) exceeds 4500 rev/min, the flow of air to the starter is stopped by de-energizing the starter air regulating valve, and the starter overrunning clutch is thus disengaged.

Start sequence

During the start sequence the gas turbine is driven up to idle speed. This sequence is divided into three phases:

1. cranking,
 2. light-off, and
 3. acceleration to idle.
1. Upon opening the starting air regulating valve, the pneumatic starter begins to rotate and produces the necessary torque to drive the gas generator and increases its speed. As the turbine is cranked and the gas generator speed increases (*cranking operation*), lubricating oil pressure will increase.
 2. Fuel is not yet admitted to the turbine. When the gas generator reaches 1200 rpm the Advanced Engine Control Module (AECM) activates the ignition exciters, and after a delay of 1 to 2 seconds energises the fuel shutdown valves. At this point the air and fuel flow are sufficient to initiate and sustain combustion, and *light off* commences within the combustion chamber. The gas generator (compressor and high-pressure turbine) rotor is now driven by the combined efforts of both the starter and the ignition combustion gases.
 3. When gas generator speed (N_{GG}) reaches 4500 rpm the AECM disables the starter and de-activates the turbine igniter system. At this point the gas generator rotor will continue to *accelerate to idle* speed with no further assistance from the starting and ignition components.

If fuel is injected before the ignition exciters are activated, there will be an abnormal start. Depending on how much fuel that is injected, there will be a degree of 'hot start' (with possible damage of the gas turbine) or the ignition exciters could fail as no spark can be generated when they are wetted by the fuel.

2.4 Water Wash System

Onboard - periodic water washing of the gas turbine compressor and high pressure turbine are required to maintain engine performance at rated levels.

Water wash is performed by:

- motoring the gas turbine,
- injecting a cleaning solution into the gas turbine main gas flow path
- providing a 15 minutes soaking period, and then
- motoring the engine again several times with water.

A complete water wash should be performed every 72 hours of running time (depending upon the quality of fuel used). Off line cleaning should not be initiated until the engine skin temperatures have dropped to 93°C or lower. Also water washing should not be carried out when the ambient temperature is below 10°C.

The modelling of this system is simplified, with just a 'water wash' start command that represents the above-mentioned procedure on the simulator.

Within the compressor model a certain rate of contamination of the compressor during gas turbine operation is incorporated. The water wash operation will reduce this contamination, and hence compressor efficiency improvements after water washing are modelled.

2.4.1 Operation

1. The gas turbine must be stopped
2. Check the gas turbine temperature has fallen below 90°C
3. Press the water wash button, the “in progress” light will illuminate
4. Once the water wash operation is complete, the “finished” light will illuminate

2.5 Engine Fuel System

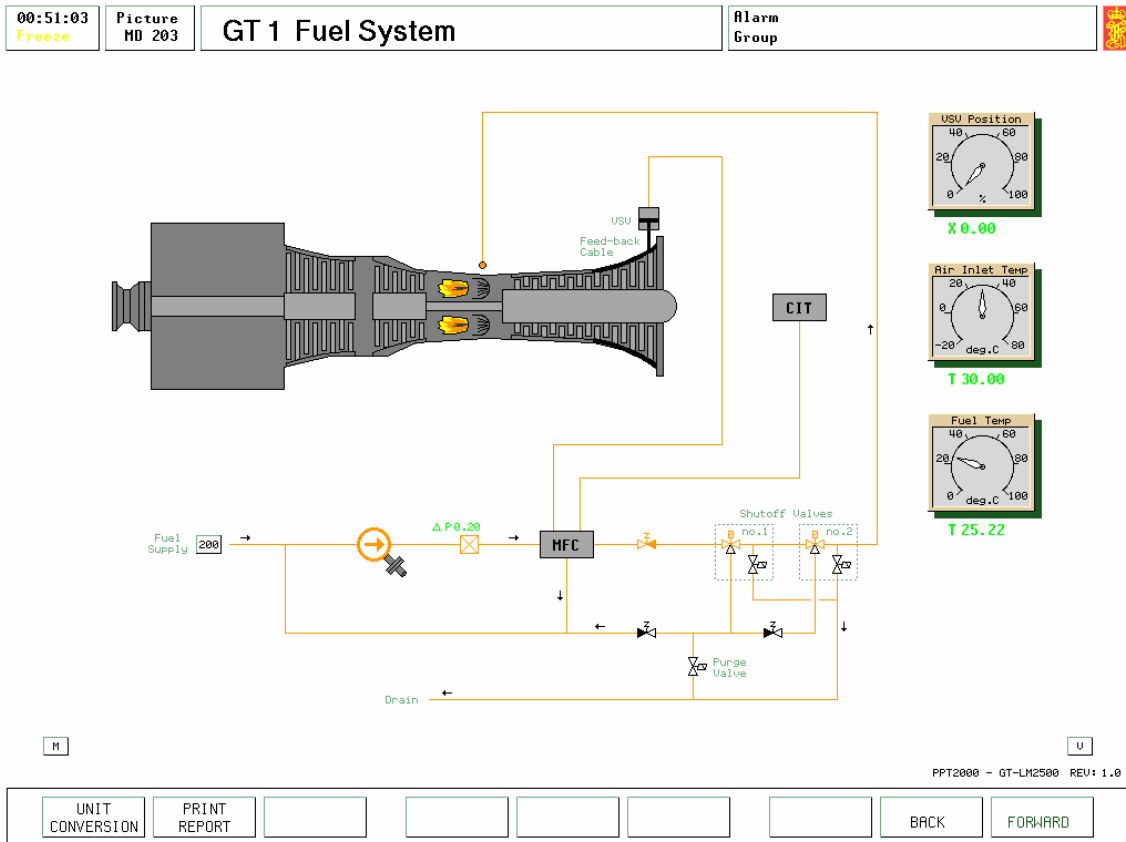

Figure 21

The Engine Fuel System is comprised by the following components:

- Fuel Pump
- Fuel Filter
- Main Fuel Control (MFC)
- Fuel Pressurising Valve
- Fuel Shutdown Valves (2 off)
- Fuel Manifold
- Fuel Nozzles (30 off)
- Compressor Inlet Temperature (CIT) Sensor
- Fuel Purge Valve
- Fuel Purge Check Valve
- Variable Stator Vane (VSV's) and Variable Stator Feedback Cable

The gas turbine fuel system regulates and distributes fuel to the combustion section of the gas generator, and thus controls the speed of the gas generator.

The power turbine speed is established by the gas stream energy level produced by the gas generator. It is not directly controlled by the fuel system, as the power turbine has a different shaft from the gas generator.

Fuel from the supply system flows through the base inlet connector to the shaft driven pump where it is pressurised up to 90 bar, for admission to the combustion chambers through the “Can Annular” type combustion chamber.

Three valves control fuel flow to the engine fuel manifold;

- 2 fuel shutoff valves, and a
- fuel-metering valve.

A hydraulically actuated fuel flow control valve meters fuel flow to the turbine according to turbine command signals, which are generated in response to changes in load demands on the turbine engine. According to the valve position, a portion of the pressurized fuel is used for turbine operation and the remainder is returned to the pump suction by the Main Fuel Control (MFC) unit. To assure an adequate supply of fuel to the gas turbine operation, the fuel pump has a higher fuel flow capacity than the gas turbine uses.

The MFC is the engine governor and contains a hydro-mechanical computer. The Power Level Angle (PLA) actuator, the compressor inlet temperature (CIT) sensor and the variable stator vane (VSV) feedback cable are associated units with the MFC. The PLA actuator is an engine mounted unit that converts electrical throttle inputs coming from the Advanced Engine Control Module (AECM). The CIT sensor is mounted on the compressor front frame in the gas turbine inlet airflow path, and provides a hydraulic (by fuel) pressure signal proportional to the inlet air temperature. The variable stator feedback cable is connected to a bell-crank operated by the VSV master lever, and provides a mechanical input to the MFC proportional to the degree of the VSV opening or closing.

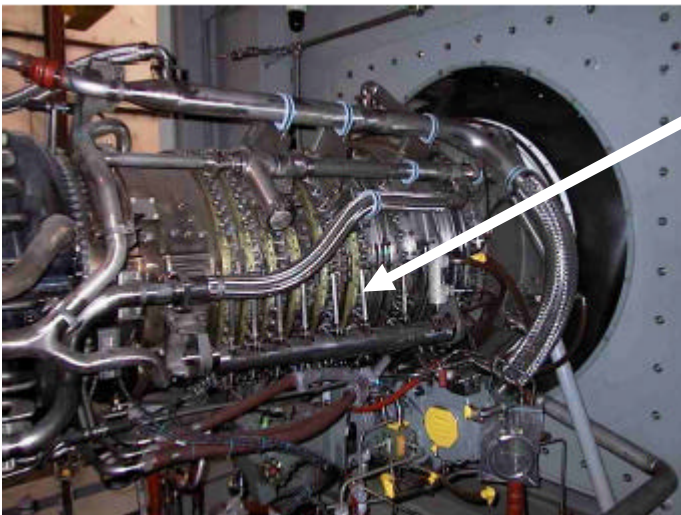

The variable stator vane (VSV) control is an electro-hydraulic system consisting of an engine mounted hydraulic pump, servo valve, and VSV actuators with integral linear variable differential transformer (LVDT) to provide feedback position signals to the main engine control.

Figure 22

The primary control functions performed by these fuel system components are combustion chamber fuel metering and VSV positioning. The fuel metering function regulates the amount of fuel delivered to the combustor in order to control gas generator speed (N_{GG})

The VSV positioning function opens and closes the compressor variable stator vanes to regulate the amount of primary airflow through the compressor, and prevent stalls within



the compressor stator vanes. VSV position is scheduled primarily as a function of N_{GG} , and secondly as a function of both the CIT sensor, and VSV position feedback.

At shutdown, the bypass solenoid valve opens in the MFC, opening the bypass valve in the metering valve, so that fuel flow to the turbine is shut off and all liquid fuel flows to the liquid fuel return line. The quick-closure shutoff valves are engine mounted, and are fail-close valves that are either fully open, to allow fuel flow; or fully closed, to prevent fuel flow.

During start-ups, the fuel control system first opens these shutoff valves, and then modulates the metering valve in pre-set increments, as controlled by the MFC.

During normal shutdowns, the MFC first closes the metering valve in pre-set increments to allow for turbine engine cooling. When the metering valve is fully closed, the MFC closes the shutoff valves. In emergency shutdowns, the MFC initiates the immediate closure of the metering valve and both the shutoff valves.

From the metering valve fuel is routed through the shutoff valves, to the liquid fuel manifold and distributed to the 30 fuel nozzles. At shutdown and during coast-down following fuel valve closure, the fuel shutoff valves drain any fuel from the manifold to the fuel manifold drain.

2.6 GT - Fire Detection and Extinguish

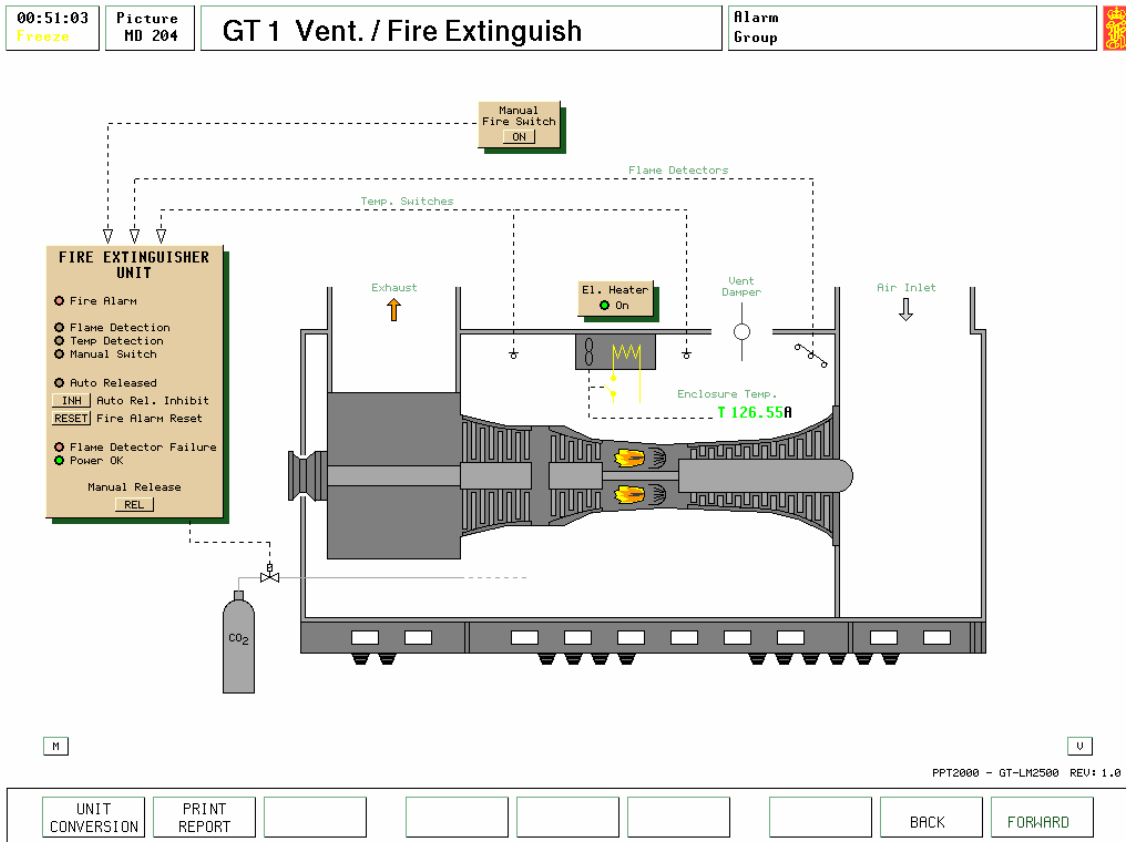

Figure 23

The fire detection and extinguishing systems consist of:

- two temperature switches
- three flame detectors
- a manual push button switch
- CO₂ cylinders
- CO₂ discharge nozzles

The temperature switches are mounted to the enclosure ceiling above the gas generator and electrically connected in parallel. The electrical sensing circuit is normally open, and closes when subjected to a temperature of 250°C or more.

The flame detectors are mounted to the ceiling at the forward end of the gas turbine environment within the enclosure.



When a fire is sensed by any of the flame detectors or the temperature switches or if the manual fire alarm is operated, the following simultaneous actions occur:

1. shut-down of the turbine mounted fuel shut-off valves
2. closing of external quick-acting fuel shut-off valve
3. closing of cooling air inlet vent damper
4. stopping of the post shut-down fan (if operating)
5. the fire alarm is activated
6. the fire alarm signal is indicated at screen MD204

From the initial alarm activation there is a delay of 20 seconds before the CO₂ is released to allow the operator a positive verification of the fire. During this time, the release of the CO₂ can be inhibited by the inhibit switch on the MD204 screen display (“INH button”).

After the 20 seconds delay, an electrical-pneumatic-actuator is automatically activated and the valves from the cylinders are opened allowing the flow of the CO₂ to the nozzles in the enclosure of the gas turbine. An indication signalling that the CO₂ has been released is indicated on MD204 (AUTO released).

The CO₂ can also be released manually from the screen display, using the button “REL” but the shut down procedures must be manually activated, as detailed in the items 1 to 6 shown above.

2.7 GT - Sensing systems

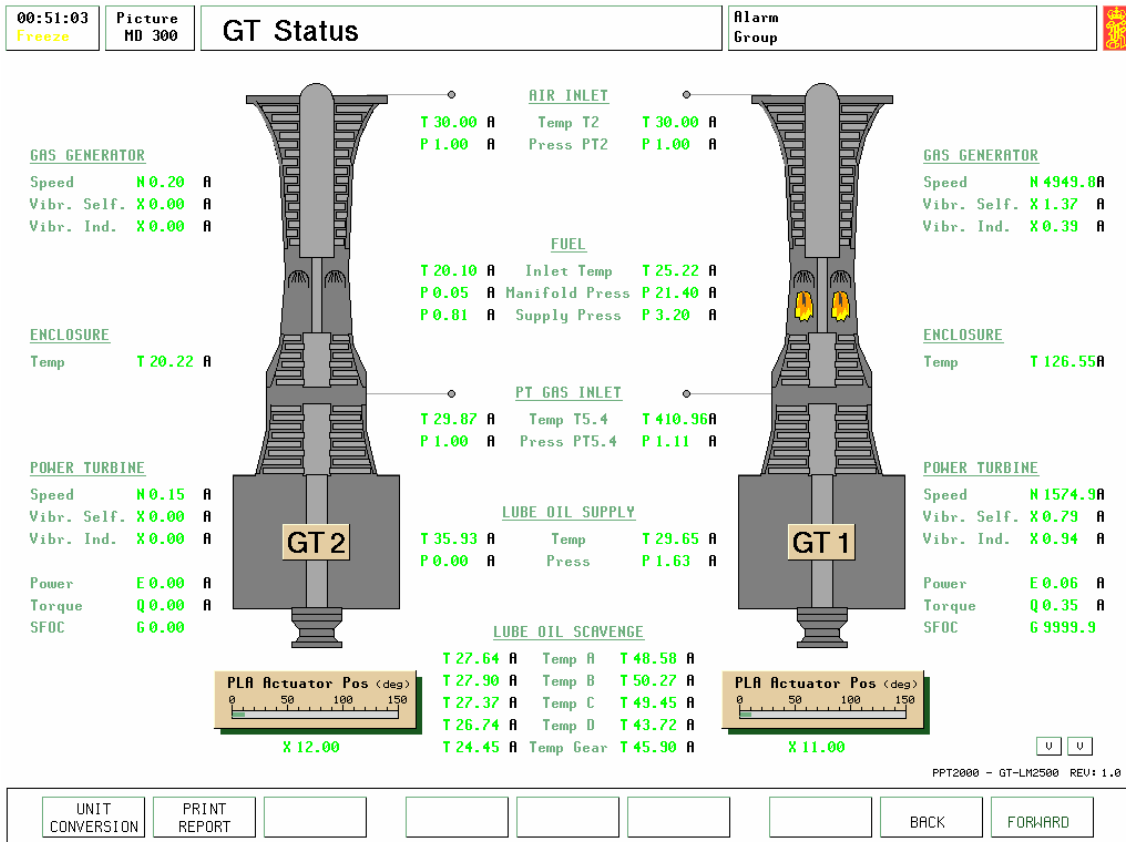

Figure 24

Numerous probes and sensors are used to control and monitor the turbine unit whilst running. They are located at strategic points throughout the gas turbine and its associated equipment, and give important information to be used by the control system in performing specific engine control functions and to indicate the main operating parameters to the duty engineer.

Engine monitored parameters include:

1. compressor inlet total pressure (PT 2)
2. compressor discharge static pressure (PS 3) {Variable page 30001 for P30002 GT1, and variable page 30011 for P40002 GT2}
3. power turbine inlet total pressure (PT 5.4)
4. power turbine inlet temperature (T 5.4)
5. gas generator speed (N_{GG})
6. power turbine speed (N_{PT})
7. gas generator and power turbine vibrations

The first six parameters are used by the Advanced Engine Control Module (AECM) to compute the gas turbine power and torque. The AECM protects the power turbine against overload and over-torque, hence changes in speed of the N_{GG} can be observed every time the power turbine limit conditions are reached.



A vibration monitoring system is installed in the software model to match actual LM2500 turbine monitoring. This will notify the engineer of excessive vibration in the power turbine and/or generator, and is displayed on screens MD300 and MD821. Each monitoring device has alarm and shutdown settings, which are set by the AECM unit.

2.8 Gas Turbine Operator Panels #1

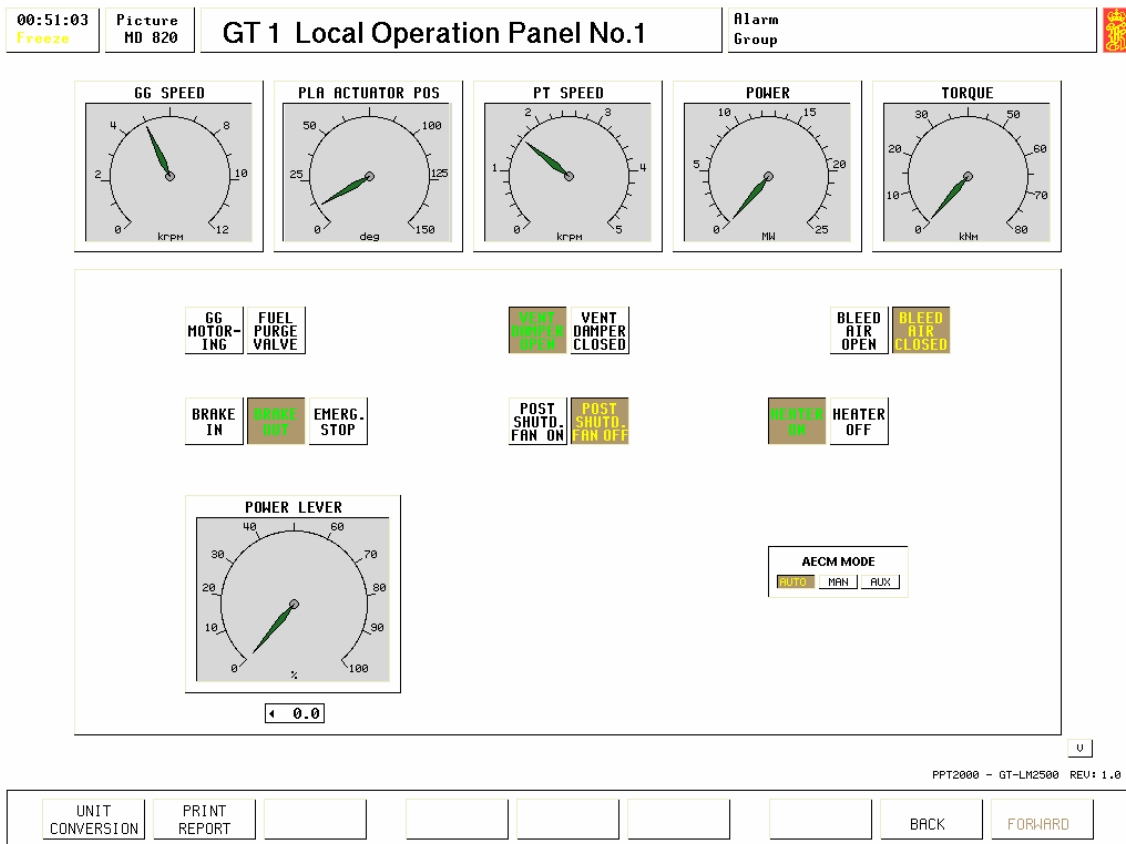

Figure 25

The Gas Turbine operator panel #1 provides the following functions:

- GG motoring: **Push button**, which is used during water washing of the turbine. The turbine is then driven on air by the starting system.
- Fuel Purge Valve: **Push button**, this will purge the fuel system, and is activated when the turbine shut-down is activated.
- Vent Damper: **Push button**, this is opened for air entry into the turbine housing. During normal operation this would be open, and closed then the turbines is shut-down, or fire is detected within the turbine enclosure.
- Bleed air: **Push button**, this will circulate the heated air from the gas generator to the compressor air inlet. This function is used when the ambient temperature is low and the humidity is high, but will reduce turbine plant efficiency.
- Brake in/out: **Push button**, selects that the turbine brake is on or off
- Emerg. Stop: **Push button**, closes the fuel shuts off valves on MD 203
- Post shutd Fan on/off: **Push button**, purges the turbine after stopping
- Heater on/off: **Push button**, pre-heats the turbine before starting
- AECM mode: **Push button**, Advanced Engine Control Module in Automatic, manual or aux. mode as required.

2.8.1 Operation

1. Check GT enclosure temperature is above 0°C. If not, then heater should be turned ON. The heater coil will connect and disconnect automatically.
2. Open vent damper
3. Ensure gas turbine brake is off

2.8.2 Bleed Air System

This system is used when the gas turbine is used at low temperatures.

The bleed air system comprises the following main components:

- icing detector
- bleed air valves (electrically operated)
- hot air pipe work
- anti-ice noses

When the icing detector sensor reports an icing situation due to the outside air conditions of temperature and humidity, the bleed air system should be operated by opening the bleed air valves on MD820 in order to distribute the hot air along the anti-ice noses. In this condition, the hot air feeds into the noses and is exhausted upwards through slots in the top of each anti-ice nose and into the incoming inlet air stream, thus heating up the mixture.

The performance of the gas turbine is considerably reduced when the bleed air is opened, as the air compressed by the gas generator is used for another purpose.

2.9 GT Local Operation Panel #2

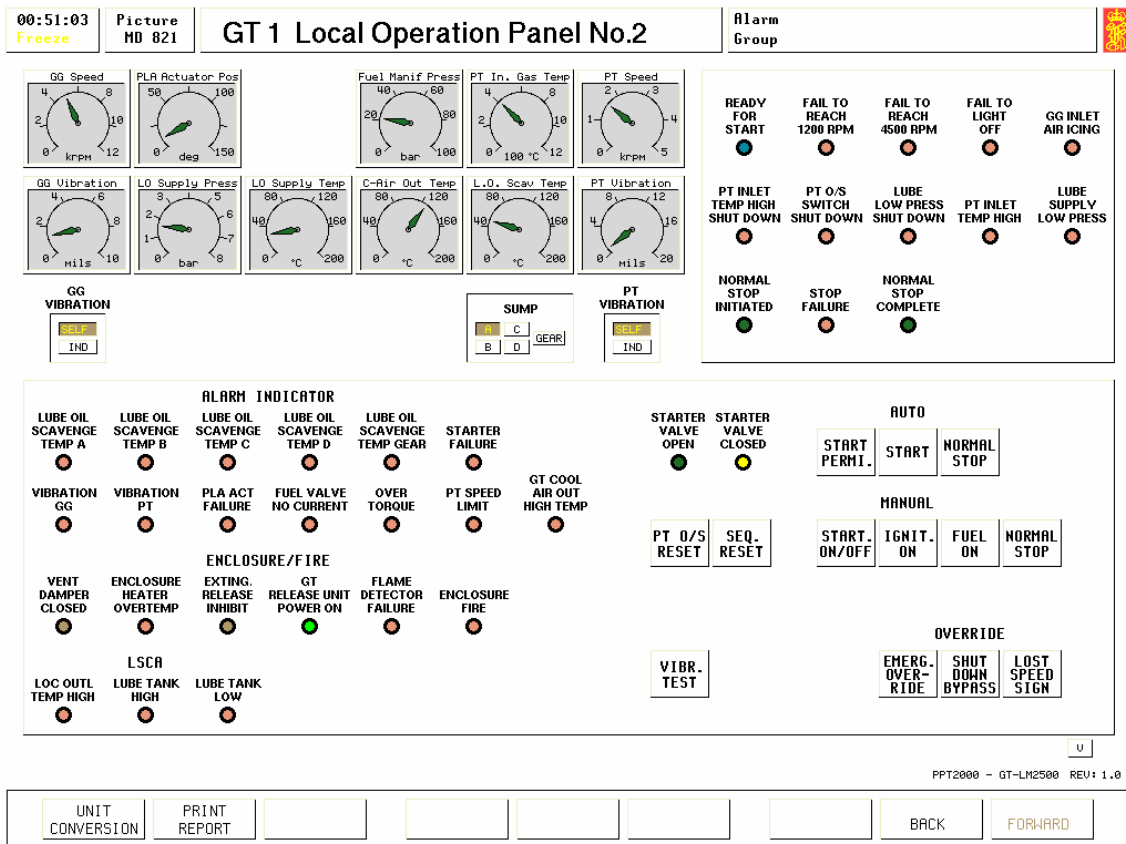

Figure 26

This screen is used together with the Local Operation Panel #1 to operate and monitor the operation of the gas turbine unit.

The following buttons are provided

- Start Permi** This indicates that starter permission is granted by the automation control and monitoring system. Once this button is lit the turbine start command can be activated.
- Start** Activation of this button will start the turbine on an automatic programme.
- Normal Stop** This button will activate the automated turbine stop sequence.
- PT O/S Reset** This button will manually reset the over-speed of power turbine.
- SEQ Reset** This button will reset the automatic start sequence. It should be reset before the automated start sequence is selected.



Start On/Off	This button is selected when manual operation of the turbine is required, and will over-ride the automated functions selected on MD821.
Ignit On	This button will automatically start the ignitor within the combustion chamber.
Fuel On	This button will open the shut-down isolation valves fitted on screen MD203.
Emerg Over-ride	This button will over-ride the shut-down functions of the gas turbine. It could be used to prevent turbine shut-down.
Shutdown bypass	This button will block the signal to the fuel bypass valve that dumps the fuel entering the gas turbine on screen MD203. It could be used when testing the turbine shut-down systems without causing the turbine to shut-down.
Lost speed sign	This button will over-ride the control shut-down that would occur if the speed signal from the power turbine were lost.

Indication lights

Ready for start	Indicates that the turbine is ready to start. This lamp will light once the “Start Permission” button is pressed on this screen, and all systems are operating.
Fail to reach 1200 rpm	Indicates that the cranking operation using the starting air starter has failed to reach 1200 rev/min.
Fail to reach 4500 rpm	Indicates that the ignition start sequence has failed when the turbine air starter is supplemented by the initial combustion start-up.
Fail to light off	Indicates that the ignition start sequence has failed.
GG inlet air icing	Indicates that the air inlet temperature is below 0°C, and that the bleed air system should be activated.
PT inlet temp high S/D	Indicates that the temperature at inlet to the power turbine has exceeded the safe limit, and that the turbine shut-down has been activated. A fire could be present within the turbine enclosure.
PT O/S switch shut down	Indicates that the power turbine has exceeded the over-speed limit of 4000 rev/min, and that the turbine shut down has been activated.
Lube low press shut down	Indicates that the oil pressure on MD201 at turbine inlet has fallen below the shut-down limit of 1.3 bar.

PT inlet temp high	Indicates that the power turbine temperature is above the alarm limit of 900°C.
Lube supply low press	Indicates that the lube oil pressure is below its alarm limit.
Normal stop initiated	Indicates that the turbine stop has been initiated, and that the turbine will now stop.
Stop failure	Indicates that the turbine has not stopped within the expected time scale. Manual intervention may be required (closing the fuel inlet valves, or applying the turbine brake if N _{GG} is low).
Normal stop complete	Indicates that the turbine has now stopped.
Lube oil scav temp A	Indicates that the oil temperature in sump A is above the alarm limit of 120°C.
Lube oil scav temp B	Indicates that the oil temperature in sump B is above the alarm limit of 120°C.
Lube oil scav temp C	Indicates that the oil temperature in sump C is above the alarm limit of 120°C.
Lube oil scav temp D	Indicates that the oil temperature in sump D is above the alarm limit of 120°C.
Lube oil scav temp gear	Indicates that the oil temperature in gear box sump is above the alarm limit of 120°C.
Starter failure	Indicates that the starter unit on MD202 has not operated when activated.
Vibration GG	Indicates that the vibration of the gas generator is excessive.
Vibration PT	Indicates that the vibration of the power turbine is excessive.
PLA Act failure	Indicates that the Power Level Angle (PLA) actuator is not responding.
Fuel valve no current	Indicates that the fuel shut-down valves on MD203 have no current, and hence can not be opened.
Over torque	Indicates excessive torque is being developed by the power turbine.

PT speed limit	Indicates that the power turbine has exceeded the speed limit, but has not yet over-speeded.
GT cool air out high temp	Indicates that the air temperature at outlet from the gas turbine enclosure has exceeded the alarm limit of 175°C.
Vent damper closed	Indicates that the vent damper on MD204 is closed.
Enclosure heater overtemp	Indicates that the electric heater within the turbine enclosure on MD204 has exceeded its temperature alarm set-point.
Exting. release inhibit	Indicates that the CO ₂ release is manually inhibited on MD204.
GT release unit power on	Indicates that the gas turbine is running, and the fire extinguishing system is ready to be activated if a fire is detected.
Flame detector failure	Indicates that the fire detection system for the turbine enclosure on MD204 has failed.
Enclosure fire	Indicates that the air temperature within the turbine enclosure has exceeded the safe limit. If the automatic CO ₂ release is not inhibited within 20 seconds, then the automatic CO ₂ release will automatically occur.
LOC outl temp high	Indicates that the oil temperature at the outlet of the lubricating oil cooler on MD201 has exceeded the alarm limit of 100°C.
Lube tank high	Indicates the oil storage tank on MD201 is at high level.
Lube tank low	Indicates the oil storage tank on MD201 is at low level and requires to be filled.

2.9.1 Start up and Shut down of Gas Turbines

Gas turbine start up procedure for gas turbine No 1 on Electrical generation (using Automatic start)

1. Screen MD201 (Lube oil system)
 - Check level in lube oil storage tank is above 50%
 - Open one supply filter (V20103 or V20104)
 - Open one scavenge filter (V20105 or V20106)

2. Screen MD200 (Fuel supply system)
 - Check both day tank levels are above 50%
 - Open day tank suction (V20001)
 - Open booster pump suction valve (V20002)
 - Open booster pump delivery (V20003)
 - Open fuel filter discharge valve (V20005)
 - Open fuel main supply valve (V20006)
 - Start booster pump (R20001)

3. Screen MD207
 - Check that the speed controller output is zero
 - Place the speed controller in AUTO

4. Screen MD820 (GT1 Local operating panel No 1)
 - Place AECM in AUTO
 - Switch Heater on
 - Take brake off

5. Screen MD821 (GT1 Local operating panel No 2)
 - Press the “Vibr Test” button to test the vibration alarms prior to starting
 - Press “Seq. Reset” button (Automatic sequence reset)
 - Press “PT O/S Reset button (Power Turbine Over-speed reset)
 - Press “Start Perm.” button. The blue “Ready to Start” light should illuminate
 - Press “Start” button. (MD 202 will show the start sequence)

6. Once the Gas Turbine has started, the gas generator speed will exceed 4500 rev/min, and the starter valve will be closed, then using screen MD820
 - Stop the heater
 - Open the vent damper

7. Check the operating conditions of the gas turbine on MD300

Parameter	Usual value	Your value
Lube oil supply pressure	1.6 bar	
Lube oil supply temp	32°C	
Gas turbine speed	5000 rpm	
Power turbine speed	1500 rpm	
Fuel manifold pressure	21.4 bar	
Power turbine gas temp	400°C	
Power turbine air pressure	2.1 bar	
Enclosure temp	105°C	

Once you are satisfied that the gas turbine is operating normally, the gas turbine can be placed on load.

8. On screen MD207

- Increase the power setting up to 37 in stages using the power control set point (X82033). Note this value can be changed at various screen, such as MD205 and MD820.
- Observe the operating parameters on MD300 as you increase the turbine power.

9. On screen MD205

- Ensure the generator magnetism is switched on and set to 50.
- Clutch in the Generator clutch, the generator speed should increase to 60Hz, and check that the generator terminal voltage is about 6600V.
- Check there is not breaker trip present, if so reset the breaker.
- Press CONN on the breaker control.

10. On screen MD207

1. Gradually increase the power control up to 75 achieve an active power output (E30001) from the generator of 15 - 15.5 MW. The maximum power control setting is 85.

11. Recheck the operating conditions of the gas turbine on MD300

Parameter	Usual value	Your value
Lube oil supply pressure	4.8 bar	
Lube oil supply temp	36°C	
Gas turbine speed	9000 rpm	
Power turbine speed	3600 rpm	
Fuel manifold pressure	49.2 bar	
Power turbine gas temp	760°C	
Gas turbine air pressure	3.5 bar	
Enclosure temp	72°C	

**Gas turbine start up procedure for gas turbine No 2 on the Water Brake
(using Automatic start)**

1. Screen MD251 (Lube oil system)
 - Check level in lube oil storage tank is above 50%
 - Open one supply filter (V20123 or V20124)
 - Open one scavenge filter (V20125 or V20126)

2. Screen MD200 (Fuel supply system)
 - Check both day tank levels are above 50%
 - Open day tank suction (V20021)
 - Open booster pump suction valve (V20022)
 - Open booster pump delivery (V20023)
 - Open fuel filter discharge valve (V20025)
 - Open fuel main supply valve (V20026)
 - Start booster pump (R20021)

3. Screen MD257
 - Check that the speed controller output is zero
 - Place the speed controller in MANUAL

4. Screen MD920 (GT2 Local operating panel No 1)
 - Place AECM in AUTO
 - Switch Heater on
 - Take brake off

5. Screen MD921 (GT2 Local operating panel No 2)
 - Press the "Vibr Test" button to test the vibration alarms prior to starting
 - Press "Seq. Reset" button (Automatic sequence reset)
 - Press "PT O/S Reset button (Power Turbine Over-speed reset)
 - Press "Start Perm." button. The blue "Ready to Start" light should illuminate
 - Press "Start" button. (MD 252 will show the start sequence)

6. Once the Gas Turbine has started, the gas generator speed will exceed 4500 rev/min, and the starter valve will be closed, then using screen MD920
 - Stop the heater
 - Open the vent damper

7. Check the operating conditions of the gas turbine on MD300

Parameter	Usual value	Your value
Lube oil supply pressure	1.6 bar	
Lube oil supply temp	32°C	
Gas turbine speed	5000 rpm	
Power turbine speed	1500 rpm	
Fuel manifold pressure	21.4 bar	
Power turbine gas temp	400°C	
Power turbine air pressure	2.1 bar	
Enclosure temp	105°C	

8. To illustrate the differing load conditions, the procedure for the GT2 will use the water brake for a load, so that the gas turbine load is dependant on the torque and speed rather than constant speed operation. As the speed of the power turbine is no longer fixed by the electrical supply (which is held constant at 60 Hz), then a speed controller is necessary for stable gas turbine operation.

9. On MD257 (GT2 Speed controller).
- Input the following values into the speed controller

Tag and name	Value
C25736 Speed controller gain	8.0
C25737 Speed controller I time	10.0
C25738 Speed controller D time	4.0
C25741 Speed controller FF1 gain	0.1
C25742 Speed controller FF1 TC 1	6.0
C25743 Speed controller FF1 TC 2	6.0
C25751 Speed controller FF2 gain	0.1
C25752 Speed controller FF2 TC 1	6.0
C25753 Speed controller FF2 TC 2	6.0

- Input the following tag names into the feedback and feed forward unit.

Tag number	Tagname	Function	Graph lower limit	Graph higher limit
N25202	Power turbine speed	Feedback	0	4000
E30001	Gas turbine power	Feed forward	0	30
Q40001	Gas turbine torque	Feed forward	0	50

10. On MD255, clutch in the water brake

11. On MD257
 - Set speed setting at 1000
 - Switch the feedback and feed forward units on,
 - Place the controller in AUTO and ON.
 - Gradually increase the speed set point from 0 up to 2000
12. On MD257
 - Increase the speed set point slowly from 2000 up to 3600 rev/min in stages over at least one minute
13. On MD257
 - Input 10 to the Torque set point for the water brake (Q25511)
 - Increase the torque set point up to 40 in stages noting the suggested loading programme rate shown below (Increasing up to full load should take about five minutes)

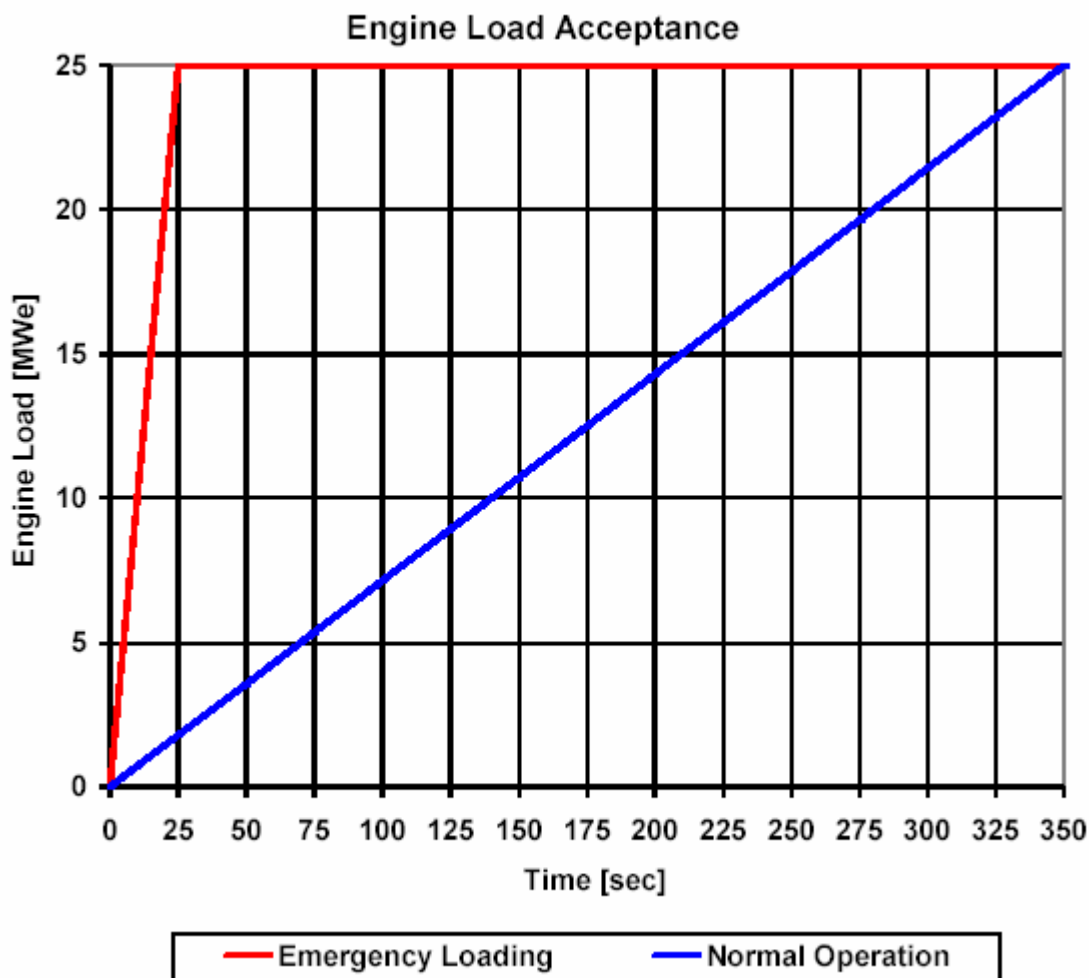

Figure 27



14. Recheck the operating conditions of the gas turbine on MD300

Parameter	Usual value	Your value
Lube oil supply pressure	4.8 bar	
Lube oil supply temp	36°C	
Gas turbine speed	9000 rpm	
Power turbine speed	3600 rpm	
Fuel manifold pressure	49.2 bar	
Power turbine gas temp	760°C	
Gas turbine air pressure	3.5 bar	
Enclosure temp	72°C	

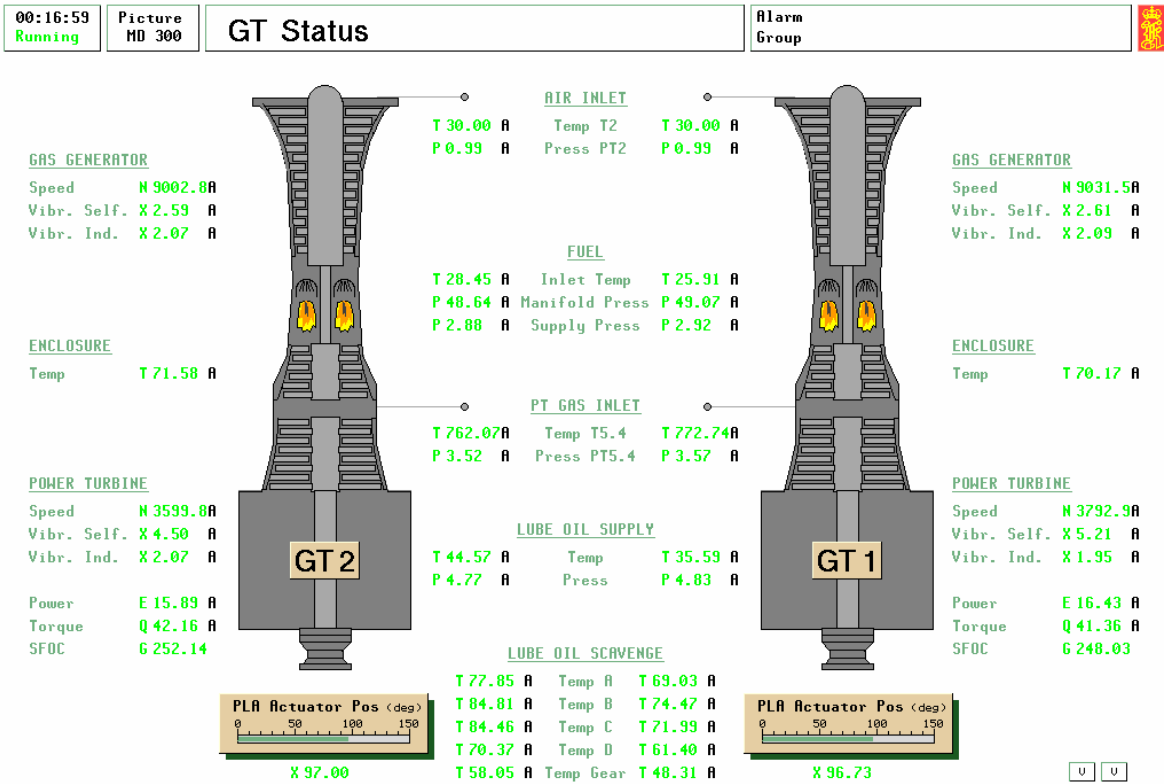

Figure 28

The status of the gas turbines following the procedures carried out for:

- Gas turbine #1 operating under water brake load
- Gas turbine #2 operating under electrical load

Gas turbine start up procedure for gas turbine No 1 (using Manual start)

Screen MD 820

- Take brake off
- Open bleed air (if the environmental conditions below 10°C, see variable page 40000)
- Ensure post shut-down fan is off
- Switch on heater
- Place AECM in MAN.

Screen MD 821

- Press the manual “Start ON/OFF” button
- The Starter valve open light will illuminate.
- When Gas Generator speed reaches 1200 rev/min,
 - press the “IGNIT. ON” button, and then
 - press the “FUEL ON” button
- When Gas Generator speed reaches 4500 rev/min,
 - de-select the “IGNIT. ON” button
 - De-select the “Start ON/OFF” button, if AECM has not already done so, and the Starter valve open light will go dark.

Screen MD820

When Gas Generator speed reaches the idling speed of 5000 rev/min;

- Press the “Damper Open” and
- Place the AECM in AUTO
- Close the bleed air valve if opened
- Stop space heater

To read the value of the gas generator speed (GT1 GG speed), the screen analogue display or the exact value on variable page 82100 could be used.

Gas turbine shut-down procedure for gas turbine No 1 (using Manual stop)

Assuming that the turbine is already unloaded from its electric or water brake load, then on Screen MD 820

- Place AECM mode into manual.

Screen MD 821

- Press the manual “Normal Stop” button

Screen MD820

- Start “Post shutdown fan”

Screen MD821

- Monitor shut-down sequence. The gas turbine will cool down for about three minutes before the fuel shut-off valves on MD203 will close to extinguish the combustion unit.

Screen MD820

- Once the gas turbine has stopped, engage the brake.

Shut-down of the gas turbine #2 from an electrical load

1. On Screen MD255
 - Reduce power control from current operating value to 30, over 5 minutes to allow the gas turbine to cool.
 - As the power control is reduced to 30, the breaker will be tested on Reverse Power trip.
 - Reset breaker after it has tripped
 - Switch off the magnetism
 - Disengage the clutch
 - Reduce the power control from 30 to zero over 1 minute
2. On screen MD921
 - Press “Normal Stop”
3. On screen MD920
 - Start “Post shutdown fan”
4. On Screen MD921
 - Monitor shut-down sequence. The gas turbine will cool down for about three minutes before the fuel shut-off valves on MD253 will close to extinguish the combustion unit.
5. On Screen MD920
 - Once the gas turbine has stopped, engage the brake.

Shut-down of the gas turbine #1 from the water brake load

1. On Screen MD205
 - Reduce the torque set point to 3.0 over 5 minutes. By leaving a small amount of torque on the power turbine, then the unit is less likely to over-speed.
2. On screen MD207
 - Reduce the speed setting(Z20732) from 3600 to 1500 over 2 minutes
3. On Screen MD205
 - Open the clutch
 - Reduce the torque set point to zero
4. On Screen MD207
 - Switch the speed controller to OFF
 - Set the Power Control setting to zero
5. On Screen MD821
 - Press “Normal Stop”
6. On screen MD820
 - Start “Post shutdown fan”
7. On Screen MD821
 - Monitor shut-down sequence. The gas turbine will cool down for about three minutes before the fuel shut-off valves on MD203 will close to extinguish the combustion unit.
8. On Screen MD820
 - Once the gas turbine has stopped, engage the brake.

3 GT LOAD SYSTEM

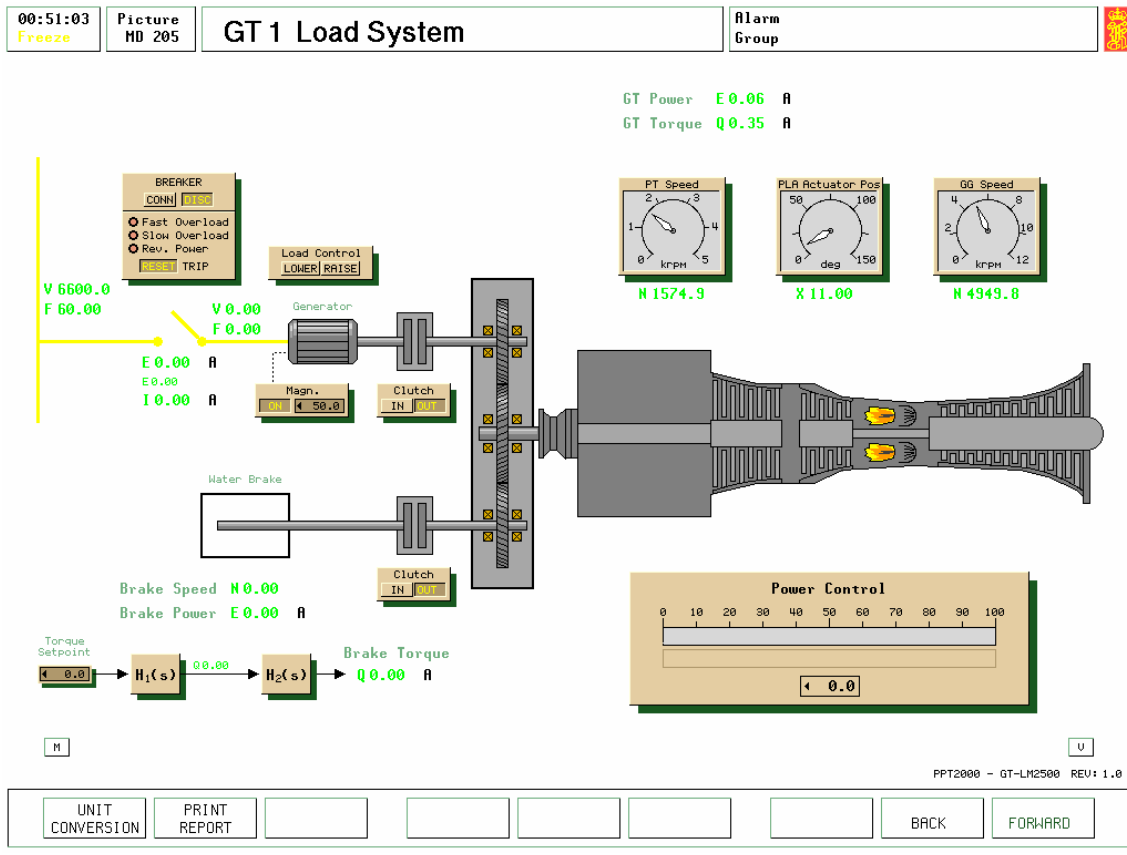

Figure 29

The two main reduction gears are operating independently from each other, and can transmit power to either load as required.

Main components of the main reduction gear:

- GT SSS (gas turbine synchro-self-shifting) clutch
- attached lube-oil pump
- attached control-oil pump
- attached seawater cooling pump
- electrically driven lube-oil pump
- electrically driven control-oil pump
- electrically driven seawater cooling pump
- turning and holding gear device
- power turbine brake
- reduction gearing
- thrust bearings

The SSS-overrunning clutch is an automatic synchronizing self-shifting clutch coupling with torque transmission via a gear-type coupling in the engaged condition. The clutch will engage automatically when the primary input rotates faster than the secondary output. Similarly it will disengage automatically when the primary input rotates slower than the secondary output.

The GT SSS clutch can be forced not to connect by means of the pawl-free position that is a mechanically actuated, and is used for gas turbine test purposes.

An electrical motor drives the turning gear. The engagement of the turning gear can only be done when the driving engines and the propulsion shaft are stationary. When the turning gear is engaged, start of the gas turbine is inhibited.

A special brake for the gearbox is provided to hold the gears and the shaft plant into a blocked position to be used in case of severe damage in the shaft plant or for maintenance reasons.

Technical data of the main reduction gear:

	Nominal Power	Nominal Speed	Max. Acceleration
Input : GT	19700 kW	3600 rpm	500 rpm/s
Output -GT driven	19700 kW	220 rpm	

Various systems are fitted to the main reduction gear, although not shown with this model:

- control oil system
- lube oil system
- seawater cooling system

The gearbox brake is connected on screen MD820.

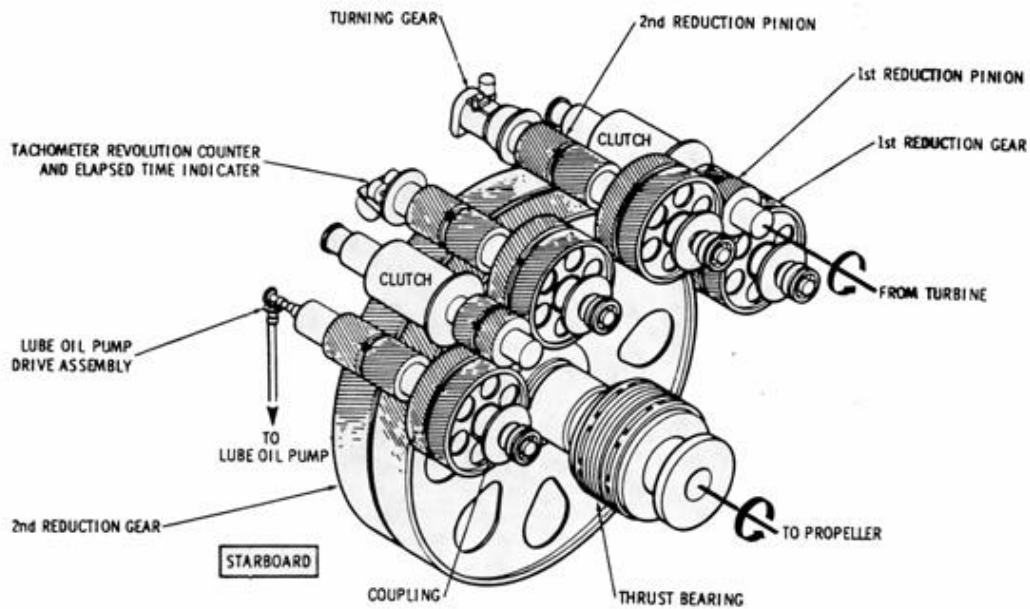

Figure 30

The reduction gearbox showing:

- Turning gear
- Lubricating oil pump drive
- Thrust bearing
- Clutch unit

3.1 Water Brake Load

Water brakes (or dynamometers) are commonly used by engine manufacturers to perform precision testing of engines with varying load. The water brake provides a well-controlled torque to the rotating shaft. The power absorbed by the brake is proportional to the rotational speed and brake torque i.e. $P = \omega T$.

The water brake is attached to the power turbine via a lamella clutch and the reduction gearbox.

The water brake is simply modelled. To apply a stable and controllable shaft torque, the applied torque is applied using two adjustable mathematical transfer functions. This will allow the engineer to simulate real and different dynamic processes.

By connecting the two transfer functions in series, each transfer function can represent a real dynamical process, thus introducing two first order lags. The output value from the first transfer function (and hence input to the second transfer function) is presented as a model variable that can be used for monitoring and control purposes.

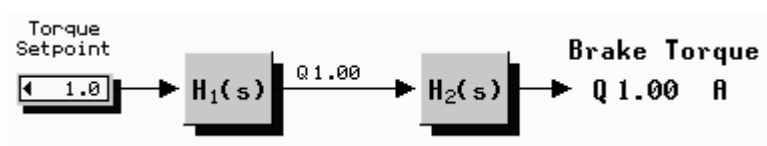

The input to the first transfer function is the “torque set point”, and the output from the second transfer function is the brake torque applied to the shaft. The dynamical behaviour or delay of the water brake is not modelled specifically, but can be regarded as a part of H_2 .

These transfer functions generate $H(s)$ which is a second order Laplace transform:

$$(3-1) \quad H(s) = \frac{1}{(1 + T_1s)(1 + T_2s)}$$

where the output brake torque is a delayed transfer of the input torque set-point. Both the two time-constants T_1 and T_2 are adjustable, and allow the system dynamics to be adjusted to suit the actual turbine operation.

The variables are adjusted on variable pages 20502 and 25502. Note if one of the time constants are set to zero, then that function will become unity and hence have no delay.

Initially the time constants could be set to

	Function 1	Function 1	Function 2	Function 2
Option 1	10	0	10	0
Option 2	5	2	5	2

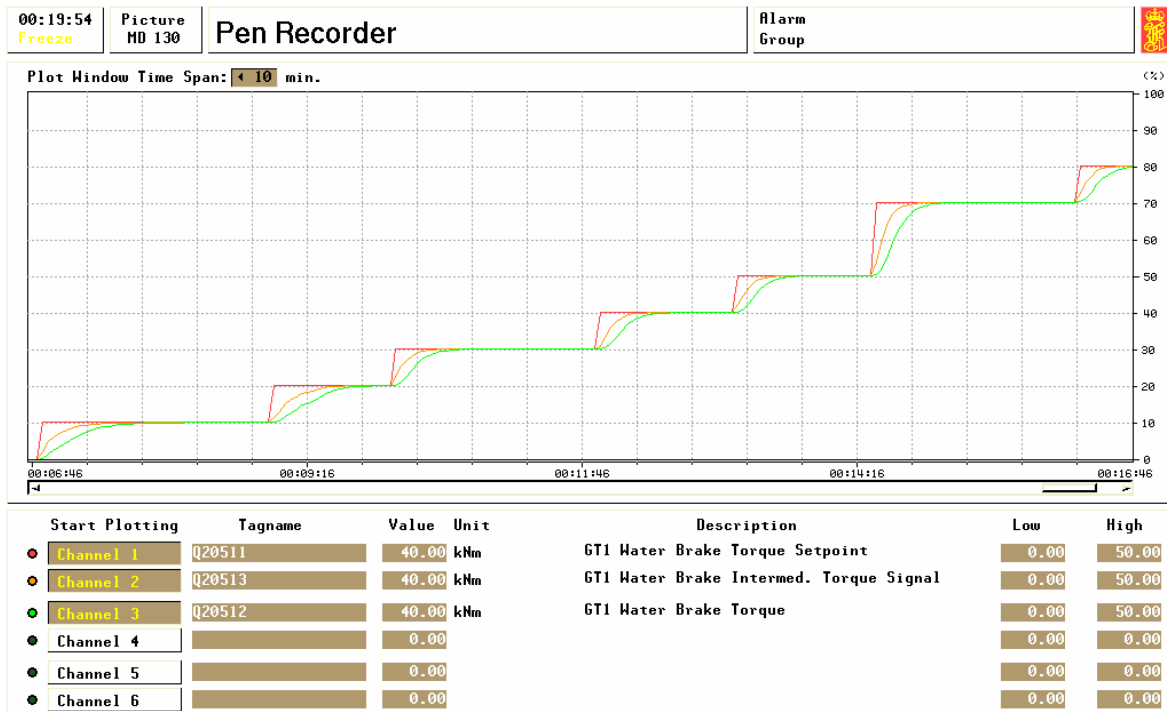

Figure 31

The pen recorder demonstrates the loading up of the gas turbine using the torque input on MD204/255. Channel 1 illustrates the set changes input into the Torque Setpoint. The two transfer functions $H_1(s)$ and $H_2(s)$ clearly provide a delay between the change of channel 1 and the changes within Channels 2 and 3.

The pen recorder screen also demonstrates the changes to these time functions, when the time constants are adjusted. The first two step changes were carried out with a time constant of 10 seconds and zero seconds for both transfer functions, whilst the subsequent five step changes were carried out with a time constant of 5 seconds and 2 seconds for both transfer functions. The 10 second delay provides a longer delay, than the 5 and 2 second delay, which provides a smaller delay than the previously set 10 second delay setting.

The model hence allows the operator to model the practical delays that would occur within an actual water brake.

4 GT SPEED CONTROLLER AND AECM

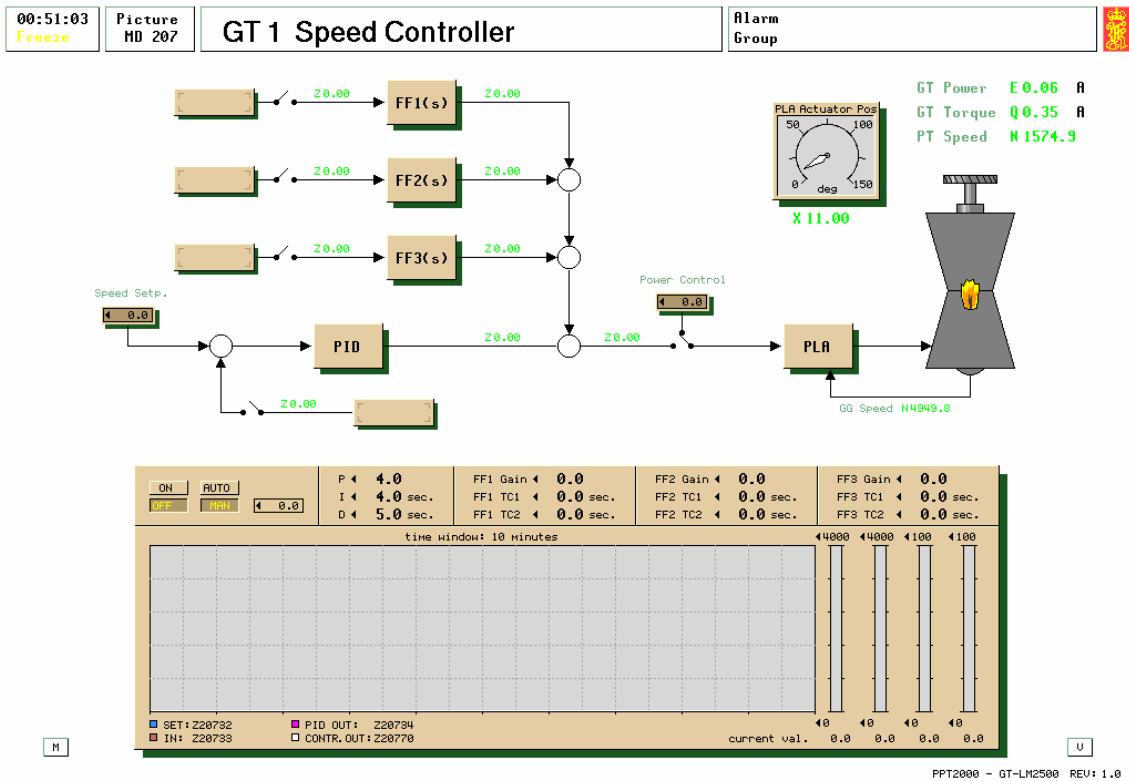

Figure 32

The main functions of the Advanced Engine Control Module (AECM) used on real gas turbine control systems are implemented in this simulator model.

The primary purpose of the AECM is control of the power turbine speed. The functional subsystems consist of:

- power level angle (PLA) actuator electronics for gas generator speed control
- the over speed switch electronics for preventing power turbine overspeed
- the microprocessor for controlling the engine start/stop sequencer and computing gas turbine output torque.

The command signal from the lever control (set at either screen MD207/257 or 820/920) to the engine is modified in the AECM unit to ensure safe operation of the gas turbine. This signal is then directed to the PLA actuator, which moves the Main Fuel Control (MFC) position on either MD203/253, to the desired output.

The command signal is modified to limit the PLA actuator acceleration, and hence power turbine acceleration, power turbine speed and power turbine output torque.

The start and stop sequence can be controlled either manually or by a programmed time sequence. The automatic start program monitors several parameters in the gas turbine, and may be interrupted if any anomaly is detected.

4.1 Speed and Power Controller

To control the turbine speed and power, a general PID controller is added. This control function is improved by the addition of three possible feed forward signals to the output of the PID.

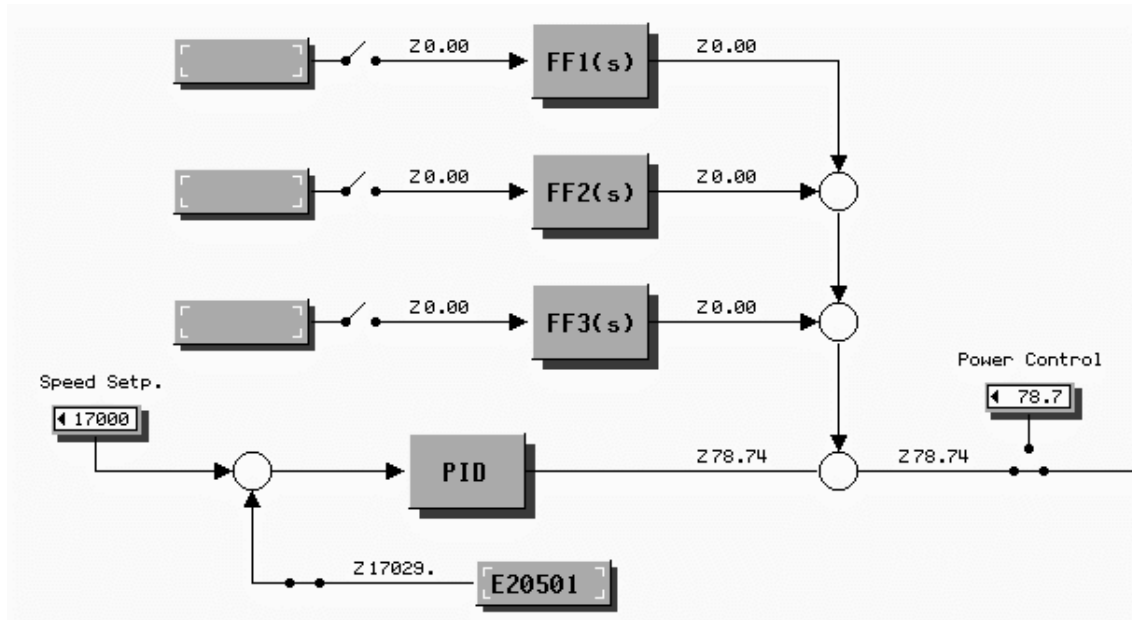

The feed back signal and the 3 feed forward signals can be taken from any variables in the simulator. This gives the user a great flexibility in configuring the control system. Each of the Feed Forward transfer functions is of the form:

$$(3-2) \quad H(s) = \frac{K}{(1 + T_1s)(1 + T_2s)}$$

A feed forward signal can, for example, be taken from the difference between two variables (x_1 and x_2) by using the same transfer functions on the two variables, with opposite sign on the K:

$$K * x_1 - K * x_2 = K * (x_1 - x_2)$$

To allow various and different parameters to be compared within the control system, the PID feedback signal and set point are converted to a percentage signal in the range defined in the “feedback and feed forward configuration” pop-up window. The PID controller and Feed Forward gain is therefore related to this scaling range.

The variable for the feed back and feed forward functions can be chosen from any of the variables present within the model. The most common and useful sensors will be gas turbine power, gas turbine torque and power turbine speed as reference. By clicking on the box for the feed back signal, the feed back and feed forward configuration menu will popup. The unique tag name for these values is placed in the required feed back and forward configuration box as shown below.

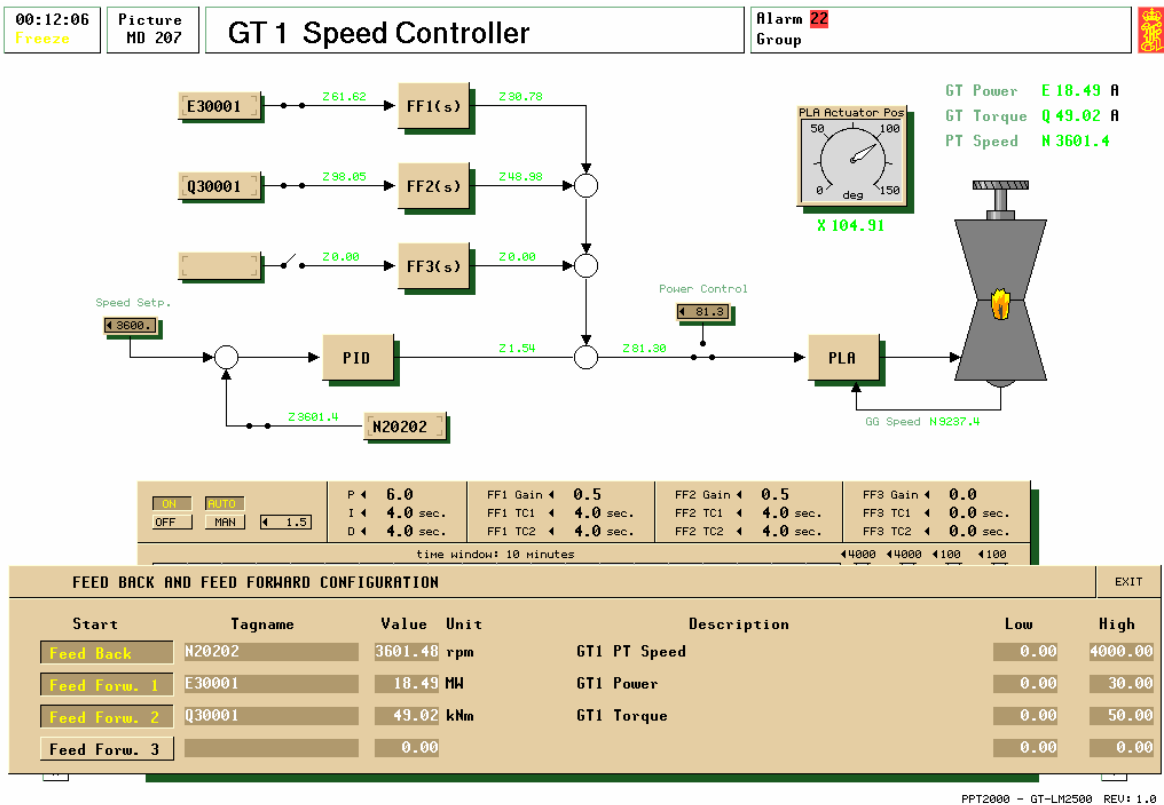

Figure 33

In this example the feedback signal is the power turbine speed for gas turbine No 1 (N20202), and two feed forward signals have been used, namely the power turbine power output (E30001) and the power turbine torque (Q30001).

Note also within this example the settings of the PID controller have been chosen as 6.0, 4 seconds, and 4 seconds. This provides a responsive and stable controller without excessive offset.

The screen example also illustrates the gain and time constants for the two feed forward signals.

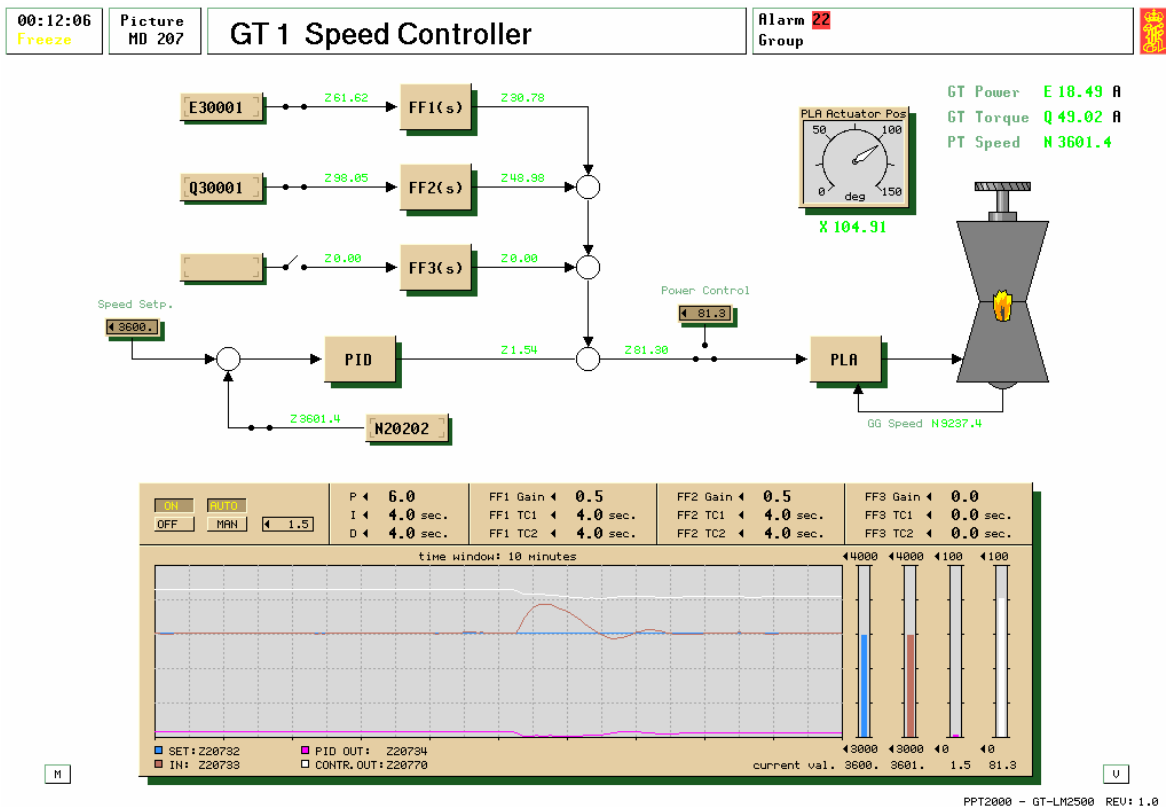

Figure 34

A change in power turbine speed when the torque is removed using a water brake load.

Speed controllers are important in gas turbine control, as any major load change in the power turbine will cause a major speed change, especially shedding of load. This could cause a possible over speed situation for separate power turbine configurations, such as in the LM2500 industrial gas turbine units. A procedure to ensure that the speed controller is set to its optimum settings is given below.

4.1.1 Optimising Procedures for Speed Controller

To optimise the speed controller at high loads using Ziegler Nicholls closed loop procedure

1. Operate the gas turbine with the water brake load at about 15 MW (torque setting of 40). This will provide a moderate load, without speed fluctuations causing an over torque or over speed.
2. Using screen MD207 for Gas turbine #1
3. Ensure that the feed forward signals are isolated by opening the pop-up menu, and de-selecting the feed forward channels.
4. Set the PID controller with values of $P = 6$, $I = 4000$, $D = 0$. Do not set I to zero or D to a large value as these may produce instability.
5. Increase the setting of P until the speed oscillations are uniform. Note after every adjustment of the P setting, the speed set point should be changed from 3600 to 3500 and back again.
6. During experiments a gain of 32 was found to just cause speed oscillations. The time period (T_o) of these oscillations was measured at 13 seconds.
7. Using the Ziegler Nicholls relationships (see page 65 for the theory involved), the suggested values of P , I and D can be found

$$P = \frac{Gain}{1.7} = \frac{32}{1.7} = 18.8$$

$$I = 0.5 \times T_o = 0.5 \times 13 = 6.5 \text{ seconds}$$

$$D = 0.12 \times T_o = 0.12 \times 13 = 1.6 \text{ seconds}$$

8. Input these values into the PID settings.
9. Test the stability of the controller by changing the speed by 200 rev/min. Return the speed to 3600 rev/min after the test. The speed controller should be stable without undue lag and offset.
10. Select or engage feed forward 1 channel with a variable of E30001 (power turbine kW).
11. Slowly increase the gain setting up to 0.2, whilst observing the stability of the speed. Set both time constants to zero seconds.
12. To test the feed forward loop we shall now change the load of the turbine at the water brake using screen MD205.
13. Increase the value of the torque set point to 42. Observe the speed controller output for stability.
14. Note the value of the variable Z20744 of the feed forward output. To ensure that the speed control loop of the PID controller is maintained as the dominant controlling mechanism, the total feed forward contribution to the overall signal should not be above 20% of the signal into the PLA actuator. You should find that at these high power levels a gain of 0.2 for the variable E30001 (turbine power) is acceptable.
15. Once the feed forward signal level is acceptable, then input values of 4 seconds into each time constant TC_1 and TC_2 to improve the feed forward stability.



16. Test the stability of the speed controller by reducing the torque set point on MD205 from 42 to 36.
17. Select or engage feed forward 2 channel with a variable of Q30001 (power turbine torque).
18. Set the gain at 0.1, whilst observing the stability of the speed.
19. To test the feed forward loop we shall now change the load of the turbine at the water brake using screen MD205.
20. Increase the value of the torque set point on MD205 to 40. Observe the speed controller response for stability.
21. The level of gain for the feed forward 2 channel should provide an output signal comparable to that of the feed forward 1 channel. Once the feed forward signal level is acceptable, and then input values of 4 seconds into each time constant TC_1 and TC_2 to improve the feed forward stability on channel 2.
22. Provide some speed and load changes to prove the controller is both stable and responsive.

To optimise the speed controller at low loads

1. Operate the gas turbine under water brake load at about 5 MW (using a torque setting of 16). This will provide a low load where the turbine speed fluctuations are not dampened by the water brake load.
2. Using screen MD207 for Gas turbine #1
3. Ensure that the feed forward signals are isolated by opening the pop-up menu to ensure the feed forward channels are de-selected.
4. Set the PID controller with values of $P = 6$, $I = 4000$, $D = 0$. Do not set I to zero or D to a large value as these may produce instability.
5. Increase the setting of P until the speed oscillations are uniform. Note after every adjustment of the P setting, the speed set point should be changed from 3600 to 3500 and back again.
6. The gain was found to be 24 and the period of oscillation at 17 seconds, so from Ziegler Nicholls then $P = 14.4$, $I = 8.5$ seconds and $D = 2$ seconds.
7. Input these values into the PID settings of the speed controller.
8. Select or engage feed forward 1 channel with a variable of E30001 (power turbine kW). Check that the time constants are zero.
9. Slowly over 4 steps increase the gain setting up to 0.5, whilst observing the stability of the speed.
10. To test the feed forward loop we shall now change the load of the turbine at the water brake using screen MD205.
11. Increase the value of the torque set point to 18. Observe the speed controller output for stability.
12. Note the value of the variable Z20744 of the feed forward output. To ensure that the speed control loop of the PID controller is maintained as the dominant controlling mechanism, then the feed forward contribution should not be above 20% of the speed control signal into the PLA actuator. You may find that at these power levels the gain of 0.5 for the variable E30001 (turbine power) is too high and may need reducing to 0.4.
13. Once the feed forward signal level is acceptable, then input values of 4 seconds into each time constant TC_1 and TC_2 to improve the feed forward stability.



14. Test the stability of the speed controller by reducing the torque set point on MD205 from 18 to 16.
15. Select or engage feed forward 2 channel with a variable of Q30001 (power turbine torque).
16. Slowly increase the gain setting up to 0.2, whilst observing the stability of the speed.
17. To test the feed forward loop we shall now change the load of the turbine at the water brake using screen MD205.
18. Increase the value of the torque set point on MD205 to 18. Observe the speed controller response for stability.
19. The level of gain for the feed forward 2 channel should provide an output signal comparable to that of the feed forward 1 channel. Once the feed forward signal level is acceptable, and then input values of 4 seconds into each time constant TC_1 and TC_2 to improve the feed forward stability on channel 2.
20. This adaptive control using the feed forward options can be further modified using the third feed forward channel, with a variable such as torque set point (Q20511).
21. As with the other feed forward channels the level of gain should be set to ensure that the speed controller PID controller remains dominant. Thus a gain of 0.2, and time constants TC_1 and TC_2 at 4 seconds are suggested.
22. To test the speed controller stability with the main feed back and three feed forward channels selected, reduce the torque set point to 7. This should produce a speed change that is not excessive. During testing a maximum speed change of less than 200 rev/min was observed.
23. The stability will now be tested with a torque increase. On MD206 increase the torque set point to 30. Observe the speed change on MD207. During testing speed stability was achieved within 80 seconds.
24. The table shows the effect of the feed forward on the speed controller.

	Speed fluctuation Feed forward ON	Time to stabilise Feed forward ON	Speed fluctuation Feed forward OFF	Time to stabilise Feed forward OFF
Torque decrease 15 to 7	+180 rev/min	40 seconds	+ 200 rev/min	45 seconds
Torque increase 7 to 30	- 410 rev/min	80 seconds	- 620 rev/min	80 seconds
Speed decrease 3600 to 3300	- 90 rev/min	45 seconds	- 80 rev/min	30 seconds
Speed increase 3300 to 3600	+ 90 rev/min	40 seconds	+ 75 rev/min	40 seconds

25. The test results illustrate the difference in controller response time and controlled variable deviation under the influence of feed forward. When feed forward using turbine torque and power is selected, the controller becomes more responsive to load changes, and the feed forward outputs will modify the speed controller output to change the PLA actuator position. However, the influence of the feed forward will reduce effectiveness of the speed controller under speed changes only. As stability

under load is more desirable, then the influence of the feed forward is beneficial to the speed controller operation.

26. We shall also compare the settings of the feed forward and PID units when optimised at low and high loads

	P	I	D	FF ₁ gain	FF ₂ gain	FF ₃ gain
Low load (7 MW)	14.4	8.5	2	0.4	0.2	0.2
High load (15MW)	18.8	6.5	1.6	0.2	0.1	not tested

This shows the dilemma for tuning controllers. As the load increase/decreases we should use different values for the controller settings. This would create an adaptive control, where the controller is optimised for each load setting. As it is important that the controller is stable over the full load range, then the lower gain settings should be chosen for the turbine speed controller. i.e. use the low load values for the PID controller, but the high load values for the feed forward functions.

The reaction of the speed controller when the torque setting is increased from 36 to 45 with the suggested controller settings, at a nominal power turbine speed of 3600 rev/min.

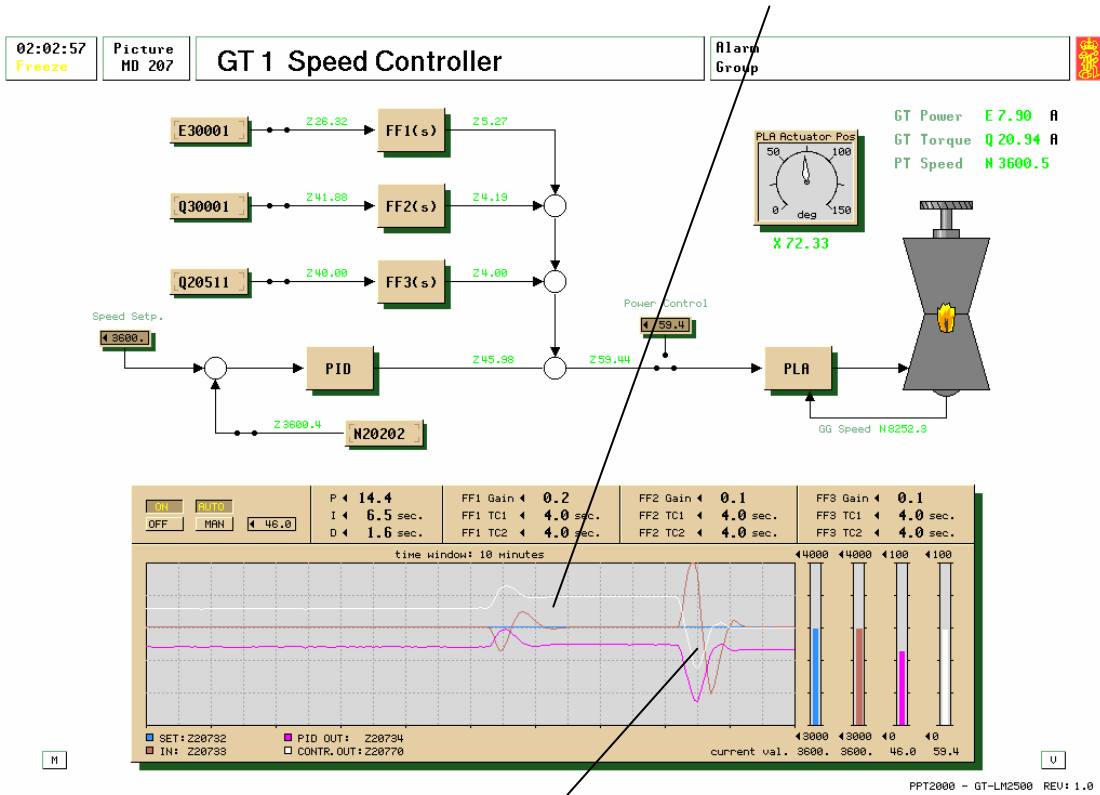

Figure 35

The reaction of the speed controller when the torque setting is reduced from 45 to 20. The higher speed fluctuation for the torque reduction is due to the reduced effect from the feed forward channel, due to the lower loads. Note the feed forward combined signal in the diagram is 15.8%, which should ensure the speed control loop remains the dominant control mechanism.

Good Control Requires:

- a) Rapid Reduction of Deviation from the Desired Value
- b) A quick return to steady state after a disturbance (A short Recovery Time)
- c) Minimum Offset

Each of these factors is affected by the controller proportional gain. The best control is obtained with the highest value of proportional gain possible before the system becomes unstable. The Maximum value of proportional gain possible depends upon the plant characteristics, and means that in some instances proportional only control is ineffective and must be supplemented by integral and/or derivative action.

Integral action is used to eliminate offset, but since it is a form of positive feedback, may lead to instability and the proportional gain must therefore be reduced when integral action is added.

Derivative action is used to reduce the recovery time and since it is a form of negative feedback, is inherently stabilising. Proportional gain can thus be increased when derivative action is added.

Every process suffers from lags to some extent. These are difficult to calculate and affect the controller settings, so that in practice controller settings are often determined by empirical means. There are a number of methods available including the Ziegler-Nicholls open and closed loop tests. The closed loop test is undertaken when a controller disturbance will not critically affect the system stability. Whereas the open loop test is carried out when the controller test could affect plant stability.

4.1.2 Ziegler-Nicholls Test

Method : Feed in a step input to the REGULATING UNIT and determine the process response curve.

- a) Change to manual control and select a new position of the regulating unit. Allow the regulating unit to reach a new equilibrium position.

Record input and output as shown.

Draw tangent to the output curve from the steepest point. Measure time intervals L and T. The steady state gain "Kp" is given by $\frac{M}{N}$.

Ziegler-Nicholls Open-Loop Test.

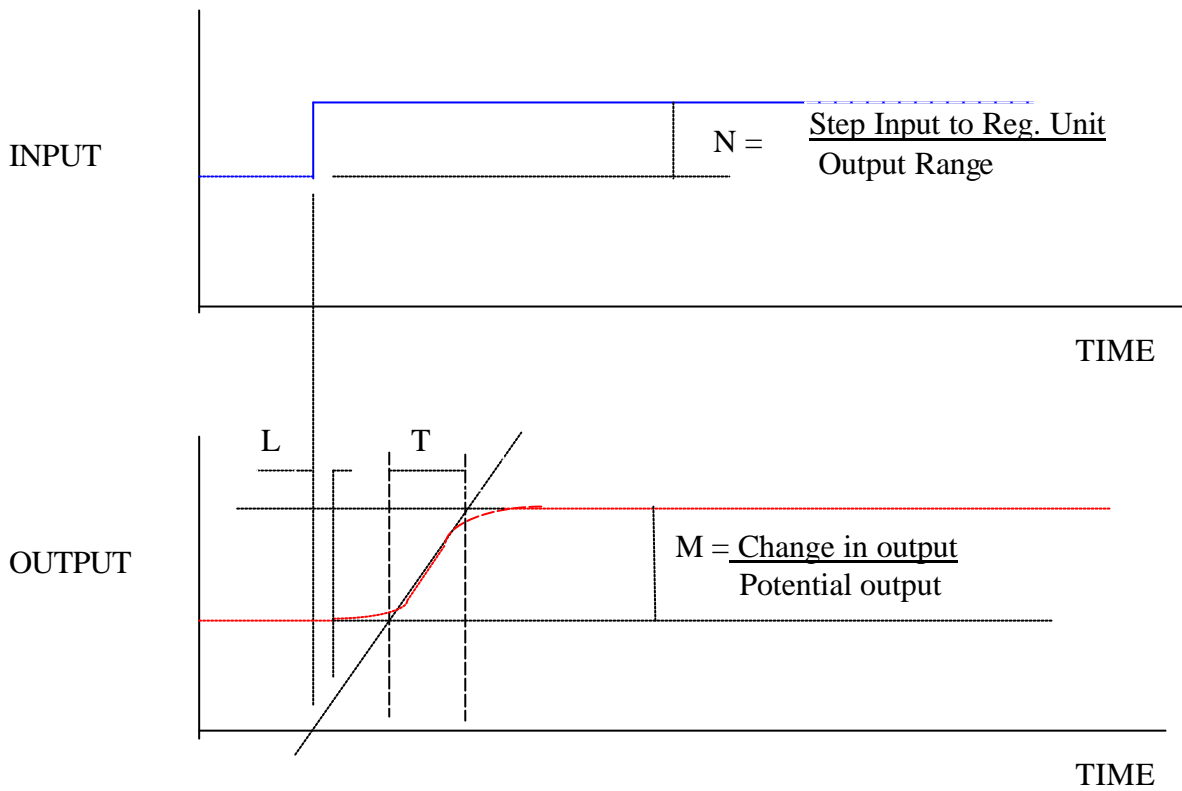

The controller gains can now be estimated as a starting point for further manual adjustment.

CONTROL TERMS	GAIN	INTEGRAL ACTION TIME	DERIVATIVE ACTION TIME
P	$\frac{T}{L \times K_p}$		
P+I	$0.9 \frac{T}{L \times K_p}$	3.3L seconds	
P+I+D	$1.2 \frac{T}{L \times K_p}$	2 L seconds	0.5L seconds

Ziegler- Nicholls Closed-Loop Test.

Method :- Alter the controller gain until process oscillates with constant amplitude.

- a) Remove effect of integral and derivative action by setting their actions times to zero, or if this is not possible, use high values of time (low action).
- b) Create a disturbance to the process by introducing a step change in the desired value setting of the controller and then returning it to its original value.
- c) Observe system response.
 - If the response is unstable, reduce gain and repeat b) and c)
 - If the response is damped, increase gain and repeat b) and c)
 - If the response is constant as shown below, then note the gain K_o and period of oscillation, T_f .

CONTROL TERMS	GAIN	INT ACTION TIME	DERIV. ACTION TIME
P	$0.5K_o$		
P+I	$0.45K_o$	$0.8T_f$	
P+I+D	$0.6K_o$	$0.5T_f$	$0.125T_f$

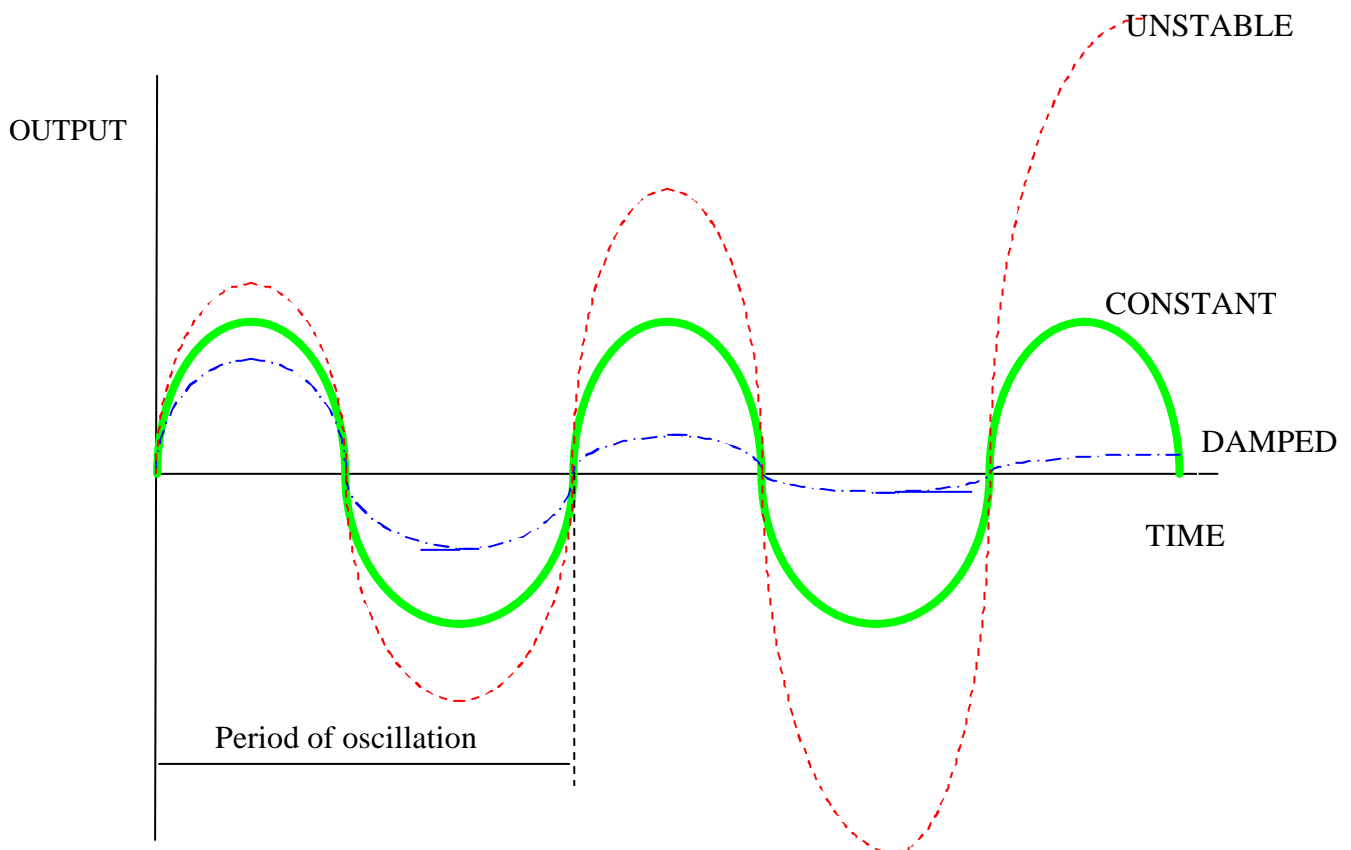

Results of Open Loop Test

$$T = 12 \text{ sec's}$$

$$N = 50/100 = 0.5$$

$$L = 2.5 \text{ sec's}$$

$$M = \frac{22.9 - 19}{19} = 0.205$$

$$K_p = M/N = 0.41$$

So, for a P + I+ D controller,

$$P = 1.2T/L.K_p = 14$$

$$I = 2.L = 5 \text{ seconds}$$

$$D = 0.5.L = 1.25 \text{ sec's}$$

This compares with the original settings of 6, 30 and 2 respectively.

Observations:-

Low time lag “L” and response time “T” make it difficult to measure accurately.

We have obtained higher values of gain and integral action, which is surprising because the Z-N test normally gives “conservative” results. However, we do have more derivative action which would balance the higher proportional gain and integral action.

It could be that when there is less load on the system the controller is less stable, and if this is so, a second test under these conditions might yield lower values of gain and integral action.

Results of Close Loop Test

$$\text{Critical gain } K_o = 12$$

$$T_f = \frac{20 \times 60}{29} = 41 \text{ seconds}$$

So, for a three term controller,

$$P = 0.6K_o = 7.2$$

$$I = 0.5 \times 41 = 21 \text{ seconds}$$

$$D = 0.12 \times 41 = 5 \text{ seconds}$$

This compares with initial settings of 2, 100, and 5 respectively.

So we have obtained higher values of gain and integral action, which is surprising because the Z-N test normally gives “conservative” results. However, there is nothing to say the initial settings are correct! It could be that when there is less load on the system the controller is less stable, and if this is so, a second test under these conditions might yield lower values of gain and integral action.

Summary

Control system instability can arise from a number of causes, but most commonly arises from having too much proportional gain in a system. This might seem strange at first glance, since proportional control is said to be “inherently stable”, because the output is proportional to the deviation. The problem arises due to the inherent “lags” in the plant which mean that the controller action may become out of step with what is actually happening on the plant.

Proportional gain should be as high as possible, but not so high as to produce instability. Note that as the load on a plant changes, its characteristics may also change, and that the controller settings used successfully at one load may produce instability at a different load.

4.2 Types Of Control Action

4.2.1 Proportional Action

In proportional control the output is proportional to the deviation. Proportional control is inherently stable and is used as a function of all multi-term controllers.

The amount the measured value of the controlled condition must change in order that the control valve moves from fully closed to fully open position is known as the proportional band and is expressed as a percentage of the instrument scale. For example, if the instrument scale is 0-100°C, and a temperature change of 70-90°C (= 20°C) causes the valve to move from fully open to fully closed then Proportional band = $20 \times 100\% = 20\%$

Note! The **GAIN** of the controller = $\frac{100\%}{PB}$ That is they are **INVERSELY** related

The proportional band setting required for any given application will depend on plant characteristics and the various lags in the control loop. There is an optimum value which will give stable control. If the gain is too high (proportional band is too low), the process will go unstable, while if gain too low (high proportional band) the process will be sluggish.

4.2.2 Offset or Droop

All proportional controllers suffer from the disadvantage that if a load change takes place on the plant the control point will not come back to the desired value. This is because there is only one valve position that coincides with the desired value. If the load changes, a different valve position is required for the same desired value. This cannot come about unless there is a change in measured value, i.e. deviation from the desired value. The plant will therefore settle down with a steady state deviation (offset) from the desired value. This offset will only be removed if the load on the plant returns to its original level.



Offset will be at a minimum when the gain is at its optimum setting, i.e. at a point just before the plant starts to hunt. The higher the proportional gain, the lower the offset after a change in load, but since high controller gain may lead to instability, this may not be an option.

4.2.3 Integral Action or Reset

Where, due to transfer lags, etc. it is necessary to use low gain to achieve stable control, offset will occur after a load change. On some plants no offset can be tolerated. On a high pressure boiler, for instance, it is essential that the steam pressure and temperature are at fixed values.

To eliminate offset at all loads, integral action must be used. Integral action means that the output is proportional to the deviation and the time of the deviation.

The time taken for the integral action to become equal in magnitude to the proportional only action is known as the integral action time. Note that the shorter the time, the more integral action there is. Integral action is a form of positive feedback and can therefore lead to instability if too much is used.

4.2.4 Derivative Action or Proportional Rate

On a large and sudden load change the proportional action tends to cause a large overshoot and undershoot to take place on the plant with an increase in recovery time before the process stabilises. To cut down on the amount of plant swing, and decrease the recovery time, derivative action is used.

Derivative action means that the output is proportional to the rate of change of deviation. Recovery time is reduced, as is the amplitude of the oscillations. Note that when the deviation is constant, no matter how large it is, derivative action will not alter the valve position. It is used where plant lags are large, i.e. temperature and pressure control but is not usually necessary for flow control.

Although derivative action has no direct effect on offset, it is a form of negative feedback and allows higher proportional gain to be used, which can reduce (but not eliminate) offset.

The input to the PLA controller of the Gas Turbine is taken from the manually set “Power Control” when the speed controller or regulator is switched off.



5 MALFUNCTION FEATURES

M20001/51 Booster pump Power failure	- >Engine keeps operating until Expansion tank empties
M20002/52 Booster Pump wear	- >33% Expansion tank level starts to drop
M20003/53 Pump suction filter blockage	- >85% Expansion tank level starts to drop
M20004/54 Pump discharge filter blockage	- >80% Expansion tank level starts to drop
M20010/60 Day tank suction valve power failure	- Valve locks in position
M20011/61 Day tank suction valve stuck	- Valve locks in position
M20012/62 Day tank suction valve fail open	- No effect ?
M20013/63 Day tank suction valve fail shut	- Expansion tank level empties, Engine stops
M20014/64 Day tank suction valve leakage	
M20015/65 Fuel Supply valve power failure	- Valve locks in position
M20016/66 Fuel Supply valve stuck	- Valve locks in position
M20017/67 Fuel Supply valve fail open	- No effect ?
M20018/68 Fuel Supply valve fail shut	- Expansion tank level empties, Engine stops
M20019/69 Fuel Supply valve leakage	
M20020/70 Exp'n tank drain valve power failure	- Valve locks in position
M20021/71 Exp'n tank drain valve stuck	- Valve locks in position
M20022/72 Exp'n tank drain valve fail open	
M20023/73 Exp'n tank drain valve fail shut	
M20024/74 Exp'n tank drain valve leakage	



Page 20840 GT1 Sensors - Temperature

- M20910 GT1 GG air compr temp sensor gain
- M20911 GT1 PT gas inlet temp sensor gain
- M20916 GT1 GT enclosure temp sensor gain
- M20940 GT1 GG ice condition sensor fail
- M20950 GT1 CIT sensor gain low low temp
- M20951 GT1 CIT sensor gain high high temp

Page 20841 GT1 Sensors - Pressure

- M20913 GT1 PT gas inlet press sensor gain
- M20914 GT1 PT gas outlet press sensor gain
- M20918 GT1 Fuel oil manifold sensor gain

Page 20842 GT1 Sensors - Speed

- M20920 GT1 GG speed sensor gain high
- M20922 GT1 PT speed sensor gain high
- M20924 GT1 PT speed channel A speed loss
- M20925 GT1 PT speed channel B speed loss
- M20926 GT1 PT speed channel A over speed
- M20927 GT1 PT speed channel B over speed



Page 20843 GT1 Sensors - Vibration

M20930 GT1 Gas gen vibra pick up (self)

M20931 GT1 Gas gen vibra pick up (induced)

M20932 GT1 PT vibra pick up (self)

M20933 GT1 PT vibra pick up (induced)

M20934 GT1 Vibration detector failure

M20101 L.O. Scavenge pump wear

50% Level in storage tank drops 'til alarm at 10%. Supply Pressure drops 'til equal flows in/out tank level 4.5%. High temp alarms initiated. Increasing wear to 80% supply press slowly drops, above 90% press drops rapidly and at 92% m/c shuts down. With 92% wear selected m/c starts but shuts down after about 6min run

M20102 L.O. Supply pump wear

At 50% wear pressure drops to 1.5 plus high temp alarms
Low pressure alarm at 70%, PT vibration at 75% GG vibration at 77%
87% wear gives 0.65 bar press and shut down.
With 87% selected, m/c starts but 'flames out' after a few seconds.

M20103 L.O. Scavenge filter No 1 Blockage

M20104 L.O. Scavenge filter No 2 Blockage

M20105 L.O. Supply filter No 1 Blockage

M20106 L.O. Supply filter No 2 Blockage

M20107 L.O. Cooler fouling

- Alarm for blockage, at 100% blockage flows unchanged
- Alarm for blockage, at 100% blockage flows unchanged
- Alarm for blockage, at 100% blockage, flows unchanged
- Alarm for blockage, at 100% blockage, flows unchanged
- 5 degree rise in outlet temp for 50 % fouling.



M20900 L.O. Sep. low eff. high loss
M20901 Sump A Bearing friction high
M20902 Sump B Bearing friction high
M20903 Sump C Bearing friction high
M20904 Sump D Bearing friction high
M20905 Gearbox friction high

Page 20200 GT1 Starting and Ignition System

M20810 GT1 Starter turbine wear low effy
M20812 GT1 Starter air control valve stuck
M20813 GT1 Starter turbine shear section f
M20820 GT1 Transfer gearbox seizure
M20821 GT1 Radial drive shear section
M20856 GT1 Igniter power exciter failure



Page 20300 GT1 fuel system

M20860	MFC Fuel pump wear	<p>If switched in with only 1% wear will still cause alarms 6 – Active power high, 18 - Power high, Torque high, Gas inlet pressure high, 21 - Over torque indication. If switched in with 11% or above machine will come off board</p> <p>Can be started up with fault on. 1% wear equates to 6,500kW loss of output at full load.</p> <p>If wear increased slowly then machine will steadily shed load without any great indication as to why except that the Fuel Manifold Pressure decreases (Not too obvious), and the gas pressure and temp. to the power turbine steadily decrease. At a maximum wear of about 45% then the turbine sheds what little load it is carrying and flames out and shutting down.</p>
M20861	MFC Fuel pump filter -	Alarm at 35% otherwise nothing much. Nuisance value only
M20862	MFC Fuel pump relief valve maladjusted -	Can be set up for 25% at start-up. Very little action 'til 25%. Small incremental increases (1%) above 27% gives load shedding, large incremental increases will give shut-down. Max value 50% but only in 1% increases.
M20873	GT1 Gas gen fuel manifold leakage	<p>- 1% - fuel leakage alarm no other action</p> <p>- 2% - as above</p> <p>- 3% - fuel leakage alarm, over torque alarm, after 4/5 mins FIRE.</p> <p>- >5% fuel leakage alarm and FIRE immediately</p>
M20875	GT1 Gas gen fuel valve 1 stuck open	- No reaction unless both valves selected



- M20876 GT1 Gas gen fuel valve 2 stuck open - No reaction unless both valves selected
- M20877 GT1 Gas gen fuel valves stuck open/closed - Effectively both valves stuck open, machine can only be stopped by shutting off fuel.

Page 20301 GT1 Variable stator vanes

- M20870 GT1 Gas gen VSV actuator stuck 50% starts to drop load, Power turbine temp and pressure decrease
100% - over torque alarm and load increase
- M20871 GT1 Gas gen VSV feedback wire failure On - Goes into overload conditions giving over torque alarm and increase in PT temp and pressure
- M20872 GT1 Gas gen VSV actuator leakage 100% - nothing apparently changes even with change of load - not sure about this one.

Page 20400 GT1 Enclosure Vent and Fire Ext.

- M20880 GT1 Enclosure damper actuator wear - closes damper
- M20881 GT1 Enclosure damper fail stuck - sticks where it is at the time.
- M20882 GT1 Gas turbine exhaust duct dirty - As increased so GT sheds load to suit.
- M20883 GT1 Enclosure heater thermostat fail on
- M20884 GT1 Enclosure heater thermostat fail off
- M20885 GT1 Post shut down fan fail
- M20886 GT1 Post shut down fan control fail
- M20888 GT1 Upper vent control fail close
- M20890 GT1 UV flame detectors power fail
- M20891 GT1 Enclosure temp switch fail (both)
- M20894 GT1 Enclosure halon rel unit power fail



Page 20500 GT1 Load system

- M20501 GT1 generator clutch failure
- M20502 GT1 generator Loss of magnetization
- M20503 GT1 Water brake clutch failure
- M20504 GT1 Water brake unstable load

Page 20700

- M20510 GT1 Speed PID Contr Gain high

Page 20800

- GT1 Gas generator
- M20800 GT1 Gas gen compr wear low effy
- M20801 GT1 Gas gen turb wear low effy
- M20803 GT1 Gas gen fuel atomisers dirty
- M20830 GT1 Gas gen high vibration
- M20837 GT1 low speed stall auto reset
- M20838 GT1 high speed stall auto reset
- M20839 GT1 Gas turbine general stall.



Page 20810 GT1 Power turbine

- M20802 GT1 Power turbine wear low effy
- M20825 GT1 Gas turbine brake control fail
- M20827 GT1 Gas turbine brake ruined -heat
- M20828 GT1 Power turbine ruined -overheat
- M20831 GT1 Power turbine high vibration

Page 20820 GT1 Inlet Air, Bleed Air

- M20840 GT1 Inlet air demister dirty
- M20841 GT1 Turbine inlet air screen dirty
- M20842 GT1 Turbine bleed air valve leakage
- M20844 GT1 Turbine bleed air valve closed
- M20845 GT1 Turbine bleed air valve open
- M20846 GT1 Air inlet demister flap stuck
- M20848 GT1 Gas gen damage ice strike

Page 20830 GTA PLA Control Panel AECM

- M20850 GT1 PLA stop idle pos signal fail
- M20851 GT1 PLA command signal fail
- M20852 GT1 Torque computer mis adjusted
- M20853 GT1 Torque computer failure
- M20855 GT1 AECM encl high temp s/s fail

6 APPENDIX 1: ALARM LIST

Doc. No.: SO-1014-A

7 APPENDIX 2: MALFUNCTION LIST

Doc. No.: SO-1015-A

8 APPENDIX 3: VARIABLE LIST

Doc. No.: SO-1016-A

9 REFERENCES

- 1 LM2500/LM2500+ Marine Gas Turbine Generator Package Product Description, Rev 0 March 2001;
GE Aero Energy Products
- 2 <http://www.ge.com/aircraftengines/>
- 3 Saravanamutto, Rogers, Cohen
Gas Turbine Theory, pp70
ISBN 0-13-015847-X